

CLIF MOCK™

# CS Sample Extractor (24 VDC, 115 VAC)

## User Manual

Manual No. 2295241-01, Rev. 01

**Technical Support Contact Information:**

Cameron Measurement Systems  
14450 John F. Kennedy Blvd.  
Houston, TX 77032  
Phone: 1-800-654-3760; 281-582-9500  
Fax: 281-582-9599

Clif Mock is a trademark of Cameron International Corporation (“Cameron”).

**Copyright © 2008 Cameron International Corporation (“Cameron”).** All information contained in this publication is confidential and proprietary property of Cameron. Any reproduction or use of these instructions, drawings, or photographs without the express written permission of an officer of Cameron is forbidden.

All Rights Reserved.  
Printed in the United States of America.

Manual No. 2295241-01, Rev. 01  
May 2008

## Table of Contents

Description .....	5
Installation.....	5
Direct Hookup .....	5
Remote Hookup .....	6
Maintenance .....	6



## Description

The CS Sample Extractor is designed to provide samples of flowing liquids in a cost-effective and simple operation. The extractor obtains a proportion-to-flow sample from a flow meter or measurement control system which provides a pulse to the solenoid actuation valve. Upon actuation, the extractor connects the accumulation chamber with the flow stream. In deactivation, the sample is discharged into the sample receptacle.

For dual-solenoid (two-coil) units, the pulse is routed to two actuation coils – a pulse to one side allows the sample into sample chamber and a pulse to the other side allows the sample to empty into the container.

The sample chamber can be adjusted to hold from approximately 0.5 cc to 4.0 cc per sample to provide the required volume for analysis. (To achieve the maximum size sample, the solenoid must remain energized in the open position for 1.5 to 2 seconds.)

The maximum operating pressure depends on the solenoid model used. An extractor with a single solenoid (one coil and one set of wires) has a maximum operating pressure of 150 psi. An extractor with a dual solenoid (two coils and two sets of wires) has a maximum operating pressure of 500 psi.

The CS Sample Extractor is constructed of stainless steel and is available with Buna-N<sup>®</sup> or Viton<sup>®</sup> seals.

## Installation

The CS Sample Extractor is furnished as shown in the schematic in the back of this manual. To complete installation, ensure that the customer has provided the following items:

- Power supply (24 VDC or 115 VAC single phase)
- Tubing and fittings as required for connecting the CS extractor to the sample probe/stinger
- Tubing and fittings as required for connecting the CS extractor to the receptacle

### *Direct Hookup*

1. Ensure that the pipeline is shut in and depressurized, and that all electrical power is turned off and locked out.
2. Install the probe and valve assembly, sample probe, or stinger in the upper half of the pipeline.
3. Connect the CS Sample Extractor directly to the probe using any required tubing and or fittings (Figure 1, page 6).
4. Connect the sample discharge port to the sample receptacle. Ensure that the tubing is positioned at a decline to allow the sample to flow from the discharge port down to the receptacle. This position helps reduce the risk for the tubing to become plugged.

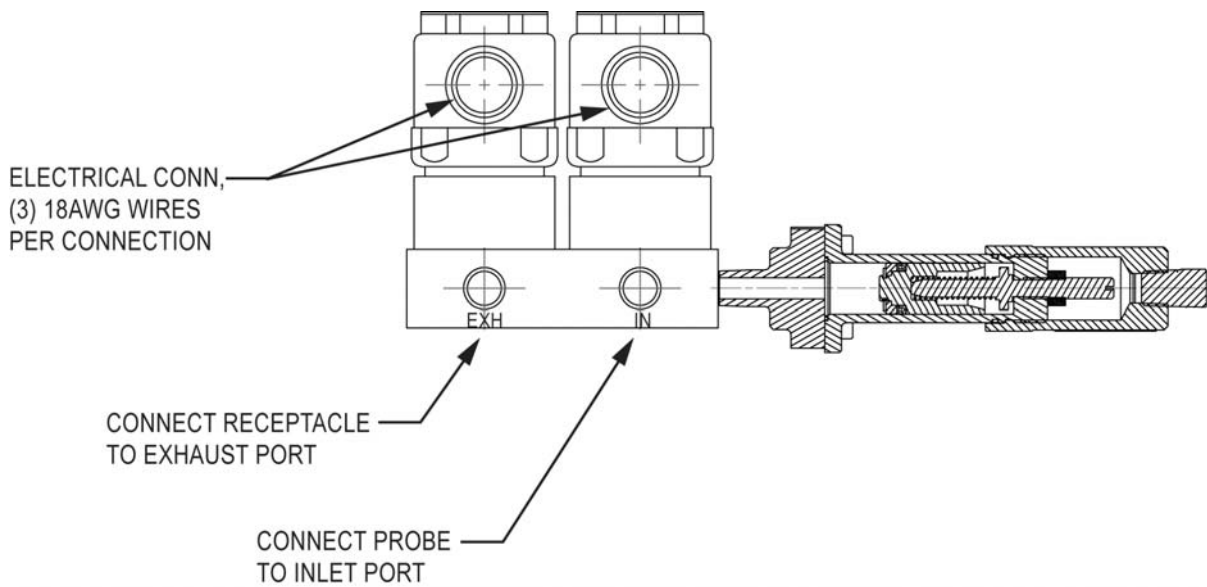

Figure 1—Direct hookup to a dual-coil solenoid

5. Connect the power supply to the solenoid. If a dual-coil solenoid is used, connect the power supply to both coils.
6. Configure the pulse output of the measurement control system. If a single-coil solenoid is used, energize the solenoid and hold it for 1.5 to 2 seconds, then release. If a dual-coil solenoid is used, send a pulse to one side to collect the sample into the sample chamber, wait 1.5 to 2 seconds, then send a second pulse to the other side for 1.5 to 2 seconds to release the sample into the receptacle.
7. With the pipeline in service, start sampling the product. Sample size can be adjusted by turning the adjustment screw clockwise/counterclockwise.

### *Remote Hookup*

1. Ensure that the pipeline is shut in and depressurized and all electricity or power is also turned off and locked out.
2. Install the probe and valve assembly, sample probe, or stinger into the upper half of the pipeline.
3. Mount the extractor onto a 2-in. pipe as close to the application as possible.
4. Using the required tubing and fittings, connect the extractor to the probe/stinger.
5. Install tubing between the sample discharge port and the sample receptacle. Ensure that the tubing is positioned at a decline to allow the sample to flow to the receptacle and to minimize the risk of plugged tubing.
6. Connect the power supply to the solenoid. If a dual-coil solenoid is used, connect the power supply to both coils.
7. Configure the pulse output of the measurement control system. If a single-coil solenoid is used, energize the solenoid and hold it for 1.5 to 2 seconds, then release. If a dual-coil

solenoid is used, send a pulse to one side to collect the sample into the sample chamber, wait 1.5 to 2 seconds, then send a second pulse to the other side for 1.5 to 2 seconds to release the sample into the receptacle.

8. With the pipeline in service, start sampling the product. Sample size can be adjusted by turning the adjustment screw clockwise or counterclockwise.

## Maintenance

---

**Note: The item numbers in the following procedure correspond to the numbers referenced in the assembly diagram and list of components on page 9.**

---

1. Disconnect the power supply or turn off the power and lock out the power supply to the sampler.
2. Close off the sample probe or remove the sample probe from the pipeline to isolate all flow from the sampler.
3. Remove the extractor from the solenoid.
4. Carefully remove the six mounting screws (item 6) that attach the accumulator to the CS extractor body.
5. Inspect the O-ring (item 7) that seals between the accumulator and the body, and replace if necessary.

---

**NOTE: If the seal leaks, pressure could be built up behind the screws. Extreme care should be exercised to ensure no one is hurt or injured by escaping pressure as the screws are removed.**

---

6. Remove the piston subassembly (items 5, 9, 10, and 15) and spring (item 11). If oil or liquid has accumulated inside the accumulator (item 4), carefully clean out and remove all liquid from the accumulator.
7. Remove the snap ring (item 10), seal retainer (item 15), and the seal (item 9) from the piston.
8. Inspect the piston seal and accumulator for damage, and replace if required.
9. Unscrew the accumulator cap (item 13) from the accumulator.
10. Inspect the O-ring (item 12) on the accumulator and replace if necessary.
11. If oil or liquid has accumulated inside the accumulator cap, carefully clean out and remove all liquid.
12. Inspect the lock nut (item 3) and adjustment screw (item 2) for damage or wear.
  - a. To replace the lock nut, unscrew the lock nut from the adjustment screw and screw the replacement back onto the adjustment screw.

- b. To replace the adjustment screw, unscrew the lock nut from the adjustment screw, and then unscrew the adjustment screw from the accumulator. Screw the replacement adjustment screw into the accumulator and screw the lock nut back onto the screw.
- c. Ensure that both the lock nut and adjustment screw are properly installed before proceeding.

---

**NOTE: If the lock nut is moved, ALL sample size settings will be eliminated and sample size must be reset.**

---

- 13. Lightly lubricate the internal parts with a light oil or mineral spirits.
- 14. Replace the accumulator cap onto the accumulator.
- 15. Replace the spring inside the accumulator, sliding it over the shaft of the adjustment screw.
- 16. Replace the piston subassembly (items 5, 9, 10, and 15) inside the accumulator.
- 17. Carefully attach the accumulator to the CS extractor body (item 8) and replace the mounting screws.
- 18. Reattach the extractor to the solenoid.
- 19. Open the sample probe to the line.
- 20. Reconnect the power to the sampler to resume sampling.
- 21. Reset the sample size, if necessary (if the lock nut was moved or replaced).



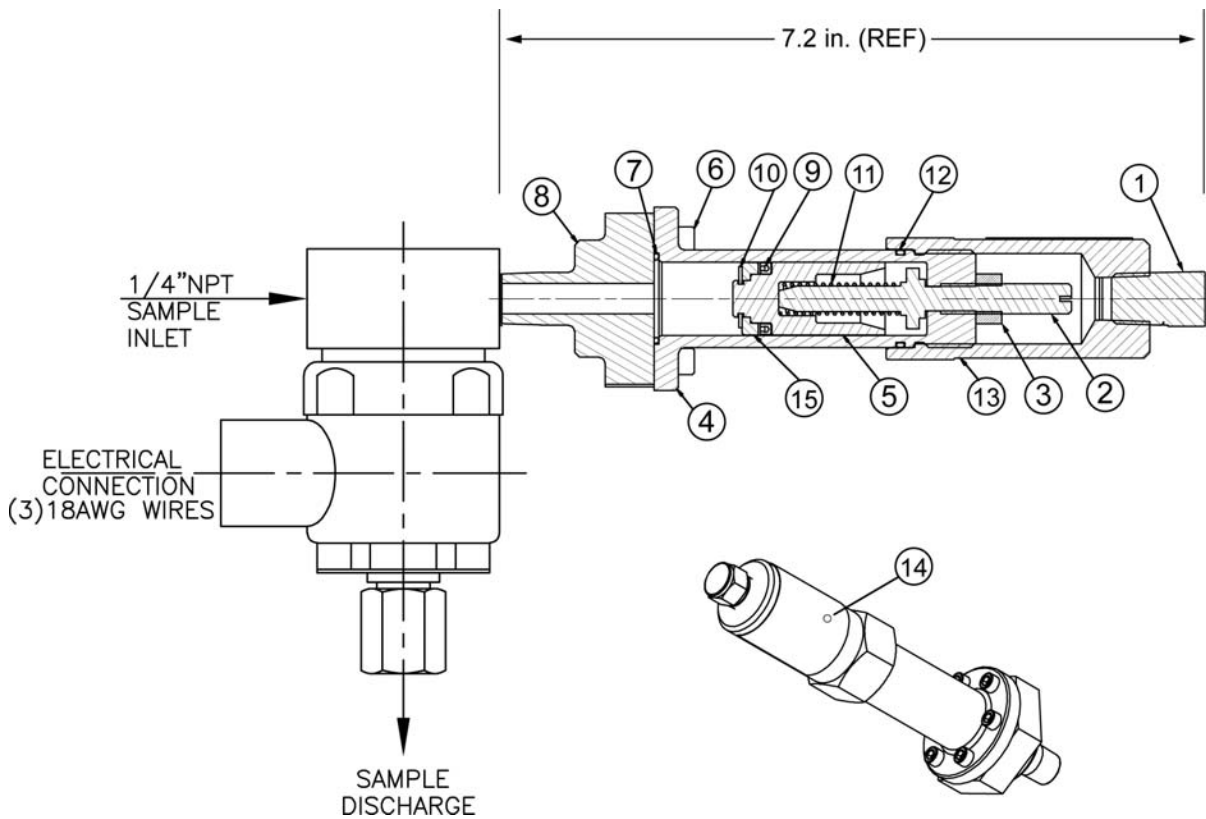

ITEM NO.	DESCRIPTION
1	PLUG, HEX, 1/4" SS
2	SCREW, ADJUSTMENT
3	NUT, HEX, 5/16-18 SS
4	ACCUMULATOR
5	PISTON, ACCUMULATOR
6	SCREW, SOCKET HEAD, 10-32 X 1/2 SS
7	O-RING, VITON #20 70 DURO
8	BODY, SAMPLER
9	SEAL, U-CUP, VITON
10	RING, SNAP, CS PISTON
11	SPRING, ACCUMULATOR
12	O-RING, VITON #019
13	CAP, ACCUMULATOR
14	TAG, SERIAL NUMBER
15	SEAL RETAINER, PISTON

### CS SAMPLE EXTRACTOR SPARE PARTS

ITEM NO. *	DESCRIPTION	PART NUMBER
7	O-RING, VITON #20 70 DURO	9A-50108500097
9	SEAL, U-CUP, VITON	9A-50108500120
10	RING, SNAP, CS PISTON	9A-50108500089
12	O-RING, VITON #019	9A-50142200462

\*See assembly drawing on previous page for location.

WARRANTY - LIMITATION OF LIABILITY: Seller warrants only title to the products, software, supplies and materials and that, except as to software, the same are free from defects in workmanship and materials for a period of one (1) year from the date of delivery. Seller does not warranty that software is free from error or that software will run in an uninterrupted fashion. Seller provides all software "as is". THERE ARE NO WARRANTIES, EXPRESS OR IMPLIED, OF MERCHANTABILITY, FITNESS FOR A PARTICULAR PURPOSE, OR OTHERWISE WHICH EXTEND BEYOND THOSE STATED IN THE IMMEDIATELY PRECEDING SENTENCE. Seller's liability and Buyer's exclusive remedy in any case of action (whether in contract, tort, breach of warranty or otherwise) arising out of the sale or use of any products, software, supplies, or materials is expressly limited to the replacement of such products, software, supplies, or materials on their return to Seller or, at Seller's option, to the allowance to the customer of credit for the cost of such items. In no event shall Seller be liable for special, incidental, indirect, punitive or consequential damages. Seller does not warrant in any way products, software, supplies and materials not manufactured by Seller, and such will be sold only with the warranties that are given by the manufacturer thereof. Seller will pass only through to its purchaser of such items the warranty granted to it by the manufacturer.

[sensiaglobal.com](https://sensiaglobal.com)

+ **Add intelligent action to your oil & gas solutions**

© Sensia LLC 2021. All rights reserved.

\* Mark of Sensia. Other company, product, and service names are the properties of their respective owners.



+