

FLOW COMPUTING

+ QRATE Scanner 3000 series flow computers

A superior electronic flowmeter and remote terminal unit for SCADA applications

APPLICATIONS

- + Hydrocarbon liquid or gas
- + Water and steam

FEATURES

- + EFM / RTU functionality
- + Selectable international measurement standards
- + PLC style programmability for specialized operations
- + Measurement
 - Up to 22 flowstreams
- + Control
 - Multiple throttling proportional-integral-and derivative (PID) controllers
- + Capex-saving wired or wireless automation architecture
- + Remote configurability

BENEFITS

- + Highly scalable
- + Cost efficient deployment features and alternatives
- + Custody transfer accuracy

QRATE Scanner 3000 series flow computers provide highly precise measurement and control to a single location with minimal automation requirements or it can be deployed as a central hub to a multidevice automation system. Each model comes field-ready with easy predeployment configurability and capex-saving wired or wireless automation architecture.



QRATE SCANNER 3100 INTEGRATED CONTROL FLOW COMPUTER

- + Rugged Zone 1, Division 1 packaging with international certifications
- + Dedicated wiring compartment with four conduit entries
- + Through-the-glass display control
- + Optional direct mounted multivariable pressure transducer



QRATE SCANNER 3300 INTEGRATED CONTROL FLOW COMPUTER

- + Compact panel mount chassis
- + Color backlight touch screen display that supports configuration and data access to password controlled authorized users
- + Integrated Wi-Fi operating as a client or access point
- + DIN rail space behind face plate to mount expansion input and output modules
- + Adaptable frequency inputs – any of the three-frequency input are adaptable to function as additional analog inputs
- + Power over Ethernet (PoE) capability
- + Eleven-position grounding bar facilitates tidy wiring

DATA ACQUISITION

QRATE Scanner 3000 series flow computers are a result of thoughtful research and engineering to create the best metrology flow computer. Accurate computed results require high-integrity input data, and the QRATE Scanner 3000 series flow computers are unparalleled in this regard. Each analog input, including the multivariable sensor, can be set to sample ten times per second which enables capturing flow pulsations that would be missed by ordinary once per second sampling. The sampling for the QRATE Scanner 3000 series flow computers is not only fast but also precise, with each acquired value having been resolved to one part in 16 million. The final key to excellence in data acquisition is simultaneous data capture. Sensia took unprecedented care to build each model with 10 analog-to-digital converters. This enables the measurement of pressure, temperature, and flow as each occur, ensuring the measurements are not offset by the latency of a multiplexed data sampling system.

Analog to Digital Converters

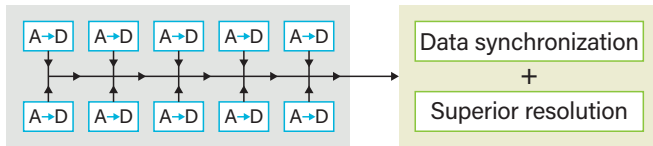

10 analog-to-digital converters to ensure data synchronization and superior resolution.

COMPUTING

Without networking to expand the number of inputs, a QRATE Scanner 3000 series flow computer can compute one bidirectional flowstream or two unidirectional flowstreams in accordance to any of the 12 imbedded industry measurement standards and techniques. In each flowstream, pressure, temperature, and composition information is taken into consideration to compute volume and mass for hydrocarbon liquids and volume, mass, and energy for water, steam, and natural gas. Gas composition may be automatically retrieved from a gas chromatograph. Liquid composition may be derived from values retrieved from a mass meter, densitometer, or water cut analyzer.

Any of the three unused frequency inputs can be used as a totalizer. For example, one QRATE Scanner 3000 series flow computer can automate both a three phase group separator and a three phase test separator by measuring the gas, net oil and water flows in each.

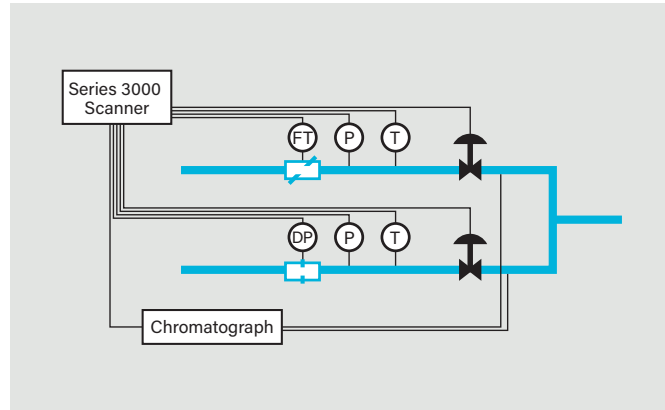
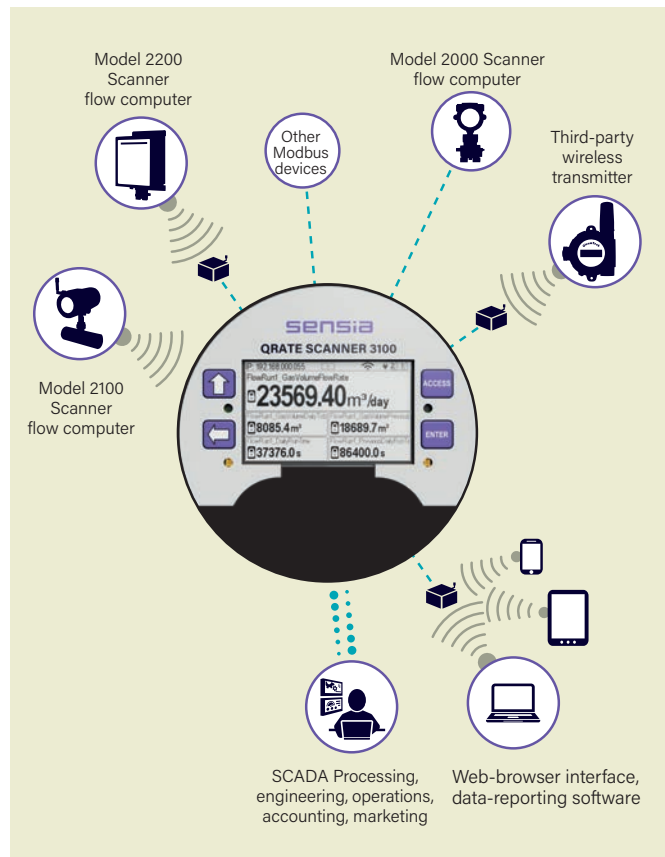

An application of a QRATE Scanner 3000 series flow computer without expansion I/O or distributed measurement networking

CONTROL

Simultaneous with flow computing, any QRATE Scanner 3000 series flow computers can execute two PID throttling controls by modulating the 4-20mA outputs. A third PID throttling controller uses status outputs to actuate a variety of digitally controlled valves. Digital outputs can also be configured as on-off controllers.

Another standard feature of all QRATE Scanner 3000 series flow computers is four user-programmable scripts for performing special computations and control strategies. To protect data integrity, custom programs execute in a sand-boxed environment within the multi-core microprocessor.

EXPANSION I/O—MODBUS MASTER

Any or all of the six available communication ports, including the Wi-Fi automation port can be used to collect data from or write data to other automation devices using various Modbus protocols. Each port can manage 128 Modbus registers for a combined capacity of 640 registers. A popular use of the Modbus master capability is to expand the quantity of inputs and outputs. Space is provided on the model 3300 to mount expansion I/O modules of various manufacturers.

RTU FUNCTIONS

Data from within a QRATE Scanner 3000 series flow computer or from an external source can be applied to any or all flow computer functions such as calculations, data logs, alarms, local display, inputs, outputs, Modbus master, Modbus slave, calculator, PID controllers, and a programmable controller.

**GATEWAY AND DATA AGGREGATOR
—CAPEX-SAVING SCALABILITY**

When the quantity of measurement and control points at a site exceeds the capacity of one QRATE Scanner 3000 series flow computer, the capex-saving distributed measurement and control system is the answer.

This system expands the capacity of a QRATE Scanner 3000 series flow computer unit to 22 flowstreams. At each of the additional flowstreams a NUFLO Scanner 2000 series flow computer model is networked to a host series 3000 Scanner flow computer by RS-485 multidrop communications or by a SmartMesh® license-free wireless data link. With its fault-tolerant, self-healing, and low-bandwidth features, the QRATE Scanner 3000 series flow computer provides a seamless user experience to all data across the automation network.

DATA LOGGING

A differentiating feature of a QRATE Scanner 3000 series flow computer is its capacity to datalog. In one aspect, it is a defining feature of the Scanner flow computer distributed measurement and control system, where the QRATE Scanner 3000 series flow computer assembles a redundant multiyear database from each nearby Scanner computer. This process renders the communications fault tolerant and assures that measurement records are never lost.

In another aspect, the QRATE Scanner 3000 series flow computer offers the simultaneous use of three more types of logs: daily, interval, and triggered logs. While daily and interval



PID controller tuning tool in the QRATE Scanner 3000 series flow computer.

logs support measurement validation and financial reporting, the triggered log is intended to provide insight to operations. The triggered log provides various activation and deactivation strategies, data capture strategies, and frequencies.

Refer to the Archive Capacity section of the specification list in this document for additional details.



SmartMesh Automation Network

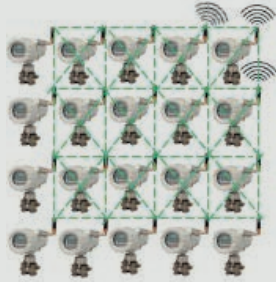

- + Up to twenty NUFLO Scanner 2000 series flow computers
- + Self-integrating, self-healing
- + Bandwidth saving, results data
- + API 21.1 compliant
- + SmartMesh encrypted protocol

Wi-Fi Automation Network



- + Up to 10 WiFi devices, any type
- + Custom integration
- + Server or client
- + Modbus TCP or over TCP
- + API 21.1 compliant

Model Specifications

	QRATE Scanner 3100* integrated control flow computer	QRATE Scanner 3300 integrated control flow computer
Approvals	Electrical: Flameproof /Explosion proof /Dust proof Waterproof to CEC, NEC, IEC, ATEX codes. See order code Pressure: ANSI 12.27.01 single seal (MVT ≤ 3,000 psi) Pressure: ASME Pressure Vessel Code (MVT ≤ 3,625 psi); CRN 0F10472.2134	General purpose CEC, NEC. Some jurisdictions do not require 12 VDC powered equipment in non-hazardous location to be certified
Environmental safety	Relative humidity 0% to 95% noncondensing Altitude: Up to 2,000 m RoHS2 EU Directive 2011/65/EU	Relative humidity 0% to 95% noncondensing RoHS2 EU Directive 2011/65/EU
Enclosure	Cast aluminum (less than 0.05% copper), painted with epoxy and polyurethane 4x corrosion resistant Double-ended with single window 4 conduit ports, 3/4-in female national pipe thread taper (FNPT) connections	Panel mount nominal 4.5 in (114 mm) x 7.5 in (190 mm)
System power†	External user-provided power supply (9 to 30 VDC, 150 mA) (9 to 24 VDC in Mexico)	External user provide power supply 9 to 30 VDC 210 mA to terminals (9 to 24 VDC in Mexico) or Power over ethernet (PoE) 44 to 57 VDC, 350mA to RJ45 socket (not incorporated in CEC, NEC assessment)
Operating temperature	-40 to 70 degC [-40 to 158 degF] LCD contrast is reduced below -30 degC [-22 degF]	-10 to 60 degC (14 to 140 degF)
LCD display/keypad	2.7-in diagonal graphic display, 400 × 240 pixels. 0.3-in-high characters Configurable dark or light background Displays up to 32 user-defined parameters, five at a time, scrolling automatically. Features include battery level indicators; wireless radio indicator; and four-button keypad and through-the-glass gesture control to advance the display, view communication settings, or activate optional WiFi	Illuminated smart phone like touch screen (1080x1920) with scroll, pinch, zoom, and pop-up keyboard features provides full configuration and information access capabilities

‡ Consult installation and operation manuals for use in Mexico.

*Scanner products were previously branded as Cameron by Schlumberger prior to the Sensia joint venture with Rockwell Automation. During the brand transition Scanner 3100 and 3300 models may be delivered with legacy Cameron brand identity.

Model Specifications

	QRATE Scanner 3100	QRATE Scanner 3300
Memory	2.18-MB RAM for processing 512-kB memory for configuration data 32+1-MB system flash 48-MB archive flash	8.18-MB RAM for processing 512-kB nonvolatile memory for configuration data 32+1-MB system flash 48-MB archive flash
Power output for field devices	10.5 V, 20 mA, protected at 50 mA for each of Analog Outputs (x4) and Pulse Inputs (x3) Power saving control with programmable warm up delay for each input	User-Programmable 9 to 24 VDC, 20 mA, protected at 50 mA for each of Analog Outputs (x4) and Pulse Inputs (x3) Power saving control with programmable warm up delay for each input
Wire terminations	Detachable power input, one RJ-45 and others fixed-screw-cage type	11-position grounding bar, one RJ-45 and others detachable screw-cage type
Analog inputs	4 channels	7 channels: 4 fixed and 3 user-configurable from pulse and frequency inputs
Analog outputs	2 channels	2 channels
Pulse/frequency (TFM) inputs	3 channels	3 channels, user-configurable as additional analog inputs
Digital I/O	6 channels, user-configurable as inputs or outputs	Outputs can indicate status or provide accumulation pulses
Resistance Temperature Device (RTD)	2 channels	2 channels

General Specifications

Real-time clock	Accurate within 2 min/year over temperature range Lithium coin-cell battery maintains clock during loss of system power (lithium content: 0.11 g)
Processor	32-bit dual-core ARM Cortex M4
Meter types	Turbine meter Cone meter Orifice meter Ultrasonic meter Positive displacement meter Coriolis meter Venturi meter
Download types	Per device Complete (all records including slave device records as applicable) Local (integral flow records in a condensed file, ideal for emailing) Events Triggered (1-second) logs (includes PID tuning) Per flow run Daily Interval (hourly) Recent (past 7 days of interval logs) Slave logs Daily Interval (hourly) Recent (past 7 interval log files produced daily)
Archive capacity per integral flow run	Up to 59 parameters Daily logs: 2,048 (5.6 years) Interval logs (configurable, 1 second to 12 hours): 24,576 hourly (2.8 years) with 14 parameters; 6,144 hourly (1 year) with 59 parameters Alarms & events 81,920 records (shared by both runs) User changes 81,920 records (shared by both runs) Downloadable via FTP, HTTP (web interface), or Enron Modbus protocol (see Scanner Data Manager* analysis and reporting software for information on viewing data files) Logs stored in nonvolatile memory for up to 10 years
Triggered archive	Data from any source Capacity 1,351,680 records with 1 parameters 135,168 records with 19 parameters Interval 1 second to years Representation Average, instantaneous, min. or max. Flow or time weighted Trigger Device alarm, real time, digital in, remote command, programmable logic
Slave archive capacity	Daily logs: 768 per slave device Interval logs: 11,264 hourly per slave device

Communications Wireless

WiFi and SmartMesh systems are available separately or together

Wired

RS-485

Two dedicated ports (port 1, 2) plus one shared RS-485/RS-232 (port 3)

Software-selectable 120-termination resistor

Selectable master or slave protocols

RS-232

Shared RS-485/RS-232 port (port 3)

TXD, RXD, RTS, CTS

Time-of-day digital output configuration

Ethernet and TCP

One RJ-45 connection supports 2 TCP/IP user-configurable ports with selectable slave or master protocols

Supports 10/100 Mbits/second

With WiFi capabilities the wired Ethernet ports can act as a DHCP client or server

Port pass-through

Any communication port can be routed to another. Ethernet can be bridged to serial communications for remotely interfacing with connected Modbus devices. (For example, Scanner flow computer slave devices can be configured via ModWorX Pro software without changing wiring connections.)

Flow rate calculations

Gases: AGA-3 (1992 and 2012), ISO 5167-2 (2003), ISO 5167-4 (2003), ISO 5167-5 (2016), ASME MFC-14M (2003), AGA-7 (2006), AGA-11 (2013)

Liquids: API MPMS 5.3, AGA-3, ISO 5167, AGA-7

Measurement compliance

API 21.1

AER Directive 17

BLM 43 CFR 3170, 3173, 3174, 3175 (pending)

MED/ NMI/ OIML R137 (pending) model 3100 only

Measurement Canada category 3 model 3100 only

Configuration lock switch with status on local display

Fluid property calculations

Gases: AGA-8 part 1&2 (includes scope of AGA 10) AGA-3, AGA-5, GPA 2145-09, IF-97, ISO 6976 (2016)

Liquids: API MPMS 11.1 (2004)

Liquid compensation and correction factors	Temperature and pressure compensation
	Meter factor compensation
Flowstreams	Shrinkage factor compensation
	Live basic sediment and water (BS&W) correction
	Live density correction
	Dynamic oil fraction (water cut) is derived from flowing density or water-cut analyzer; automatic base density updated from flowing density measurement
	Two integral unidirectional or one bidirectional compensated flow runs
	Up to 20 additional remote flow runs via local area Scanner flow computer network
RTD inputs	Three additional integral flow runs for uncompensated measurement via pulse or frequency inputs
	Simultaneous management of eight separate live or user-entered gas compositions, directing updates as assigned to the 22 compensated flow runs
	16-point calibrations for all inputs (linear factor, multipoint, and multipoint meter factor calibrations supported)
	Bidirectional flow measurement
	Stacked inputs for rangeability
	2 channels
	100-ohm platinum RTD with 2-wire, 3-wire, or 4-wire interface
	Range: -40 to 427 degC [-40 to 800 degF]
	Accuracy: 0.2 degC [36 degF] over sensing range at calibrated temperature
	Temperature effect: ±0.3 degC [0.54 degF] over operating range
A/D resolution: 24 bits	
Sample rate: 0.1 seconds to 12 hours	
Configurable shutoff for saving power when transducer warmup period is not required	
Analog outputs	2 channels
	Type 4-20mA, optically isolated, externally powered
	Accuracy (after calibration): ±0.1% of span max. error at 25 degC [77 degF]
	Temperature effect: ±50 ppm/degC [±27.8 ppm /degF]
	Output load R (ohms) = {supply (volts) – 8.0} / 0.02
	Maximum voltage: 30 V DC
	D/A resolution: 16 bits
	Calibration (zero and full-scale) via software
	Configurable to track any value including PID Control applications
	Configurable stale data response action
Analog inputs	1-5V, 0-5V, 4-20mA, or 0-20mA
	Accuracy ± 0.030% of span max. error at 25 degC [77 degF]
	Temperature effect: ±0.25% of span over operating range
	Impedance > 60 Kohm for 1-5V mode; approximately 250 ohm for 4-20 mA mode
	Over-voltage protection ± 30 VDC
	A/D resolution 22 bits
	Linearity error ± 0.020% max; ± 0.010% typical
	Single-ended inputs
	Sample rate: 0.1 seconds to 12 hours
	Four previous calibrations available for restore
Configurable shut-off for saving power	

Digital I/O	6 channels, user configurable as input or output
	DIO1, DIO2, DIO3, DIO4 are optically isolated with a max. output of 60 mA @30 VDC
	DIO5 and DIO6 are non-isolated with a max. output of 500 mA at 30 VDC
	Input types
	Control switch
	Pulse
	Open collector
	Contact closure
	Special functions
	Advance display
	Turn SmartMesh on or off
	Reset specific flowrun total
	Reset specific pulse input total
	Unlatch specific D I/O
	Acknowledge alarms
	Start or refresh WiFi
	Publish triggered archive record
	Release triggered archive latch
	Create partial archive
	Abort script program
Reset script program	
Output modes	
Pulse (based on accumulation indication or time period)	
Alarm (based on the status of any or all selected alarms—up to 32 user-configured alarms are selectable)	
Conditional (value above or below setpoint, out of setpoint range)	
Programmed (time of day or output state—normally open or normally closed)	
Digital PID controller	
Pulse output	
Maximum frequency: model 3100, 50 Hz and 3300, 500 Hz	
Configurable pulse duration (10 ms to 1 day)	
Configurable pulse representation (1 pulse = 1 Mcf) based on time or volume	
Based on any accumulator (flow run or turbine meter run)	
Alarm output	
Low or high	
Out-of-range	
Status or diagnostic	
User interface	Web browser-based (access via laptop, tablet, or smart phone)
	Complete configuration, calibration, and maintenance of flow runs, I/O, and gas streams
	Real-time data polling and data downloads
	Recent interval and daily logs (up to 7 days) viewable in interface (other historical logs viewable in Scanner Data Manager software)
	Three user security levels; up to 20 operators
	Configuration of Modbus slave and master communications

MVT SPECIFICATIONS

- + Linearized measurements for static pressure and differential pressure
- + Measures pressure in absolute and displays in gauge
- + Standard MVT has bottom ports, ideal for gas measurement
- + Can be inverted for liquid measurement (LCD autocorrects for easy viewing)[†]
- + Process temperature: -40 to 250 degF [-40 to 121 degC]
- + User-adjustable sample time and damping
- + Complies with prequalified materials of NACE MR0175/ISO 15156[‡]

[†] Side port MVT for liquid measurement is available by special order.
[‡] This certification does not imply or warrant the application of the MVT in compliance with NACE MR0175/ISO 15156 service conditions in which the MVT is installed.

MVT Accuracy

Differential pressure	± 0.05% of range for all except 30-in H ₂ O ± 0.1% of range for 30-in H ₂ O
Static pressure	± 0.05% of range
Temperature effect	± 0.25% of full scale over operating range
Stability (long-term drift)	Less than ± 0.05% of URL per year over a 5-year period
Resolution	24 bits

Effect on Differential Pressure for a 100-psi Pressure Change

Differential pressure	Zero shift, % URL	Span shift, % reading range [†] , in H ₂ O
± 30	.05	.01
± 200 [‡]	.01	.01
± 400	.04	.01
± 840	.04	.01

[†] ± indicates bidirectional capabilities.
 Example: A range of ± 30 in H₂O is -30 to +30 H₂O.
[‡] 200 psi x 300 psi has a zero shift of .007% and a span shift of 0.01%.

MVT Pressure Ranges[†]

Static safe working pressure (SWP), absolute psi	Differential pressure, in H ₂ O	Maximum overrange pressure, absolute psi
100	± 30	150
300	± 200 or 840	450
500	± 30 or 200	750
1,500	± 200, 400, or 840	2,250
3,000	± 200, 400, or 840	4,500
5,300	± 200, 400, or 840	7,420

[†] ± indicates bidirectional capabilities.
 Example: A range of ± 30 in H₂O is -30 to +30 H₂O.

Materials of Construction

Body bolts and nuts	B7/2H alloy steel, standard (see table below for alternate materials)
Process cover	316 stainless steel (SS) [†]
Process cover gasket	Glass-filled PTFE
Diaphragm	316L SS [†]
Vent/drain	SS bleed (316 SS plug is standard for NACE and coastal applications)

[†] Other materials available by special order.

Body Bolts and Nuts (nonprocess wetted)

	B7/2H alloy steel	B7M/2HM alloy steel	316 SS	17-4 PH SS	Inconel® 718
NACE use	No	Yes	No	No	Yes
Coastal use	Possible [†]	Possible [†]	Yes	No [‡]	Yes
Max. pressure, psi	5,300	1,500	1,500	3,000	5,300
Coating	Plated	Black oxide	None	None	None

[†] B7 and B7M alloy steel is susceptible to corrosion.
[‡] Chloride stress cracking risk.

SCANNER FLOW COMPUTER SOFTWARE

The PC-based software is available for download from the Sensia website free of charge.

Scanner	Data analysis, reporting, and export/conversion tool
Data Manager	Tabular and trend presentations Customized reports
ScanMap	Tool for creating optimal Modbus register maps, including user-specified units, rates, and register names for SCADA integration Firmware-specific templates Auto-generated protocol manual (for print or upload to the QRATE Scanner 3000 series computer web interface)
ScanFlash	Firmware, configuration, and custom protocol map upload utility
ModWorX Pro	Configuration of NUFLO Scanner 2000 series flow computers

COMMISSIONING, TRAINING, AND SUPPORT SERVICES

As a leading provider of flow equipment to worldwide oil, gas, and process industries, Sensia offers a full range of services and expert support to help customers improve productivity, enhance system performance, and increase profitability.

Our services include but are not limited to:

- + measurement consulting
- + start-up assistance and commissioning
- + measurement audits
- + system health checks and maintenance
- + product training and measurement seminars

For a service quote, contact your regional Sensia representative.

WIRELESS CAPABILITIES

SmartMesh	Scanner distributed measurement and control network Self-configuring, self-healing, fault-tolerant, secure connection to Scanner 2100 series Scanners Requires external antenna 2.4 GHz Transmits up to 985 ft [300 m] node to node Supports communications with up to 20 remote NUFLO Scanner 2100 flow computers (each node can transmit and receive data)	
Certifications †	North America	FCC, IC
	Argentina	CNC
	Australia/New Zealand	ACMA, R-NZ (Z571 Limited), C-Tick
	Bahrain	TRA
	Ecuador	Conatel
	Egypt	NRTA
	Europe	CE Mark, R&TTE
	India	WPC
	Indonesia	SDPPI
	Kuwait	MOC
	Malaysia	SIRIM
	Mexico	IFETEL
	Oman	TRA
	Qatar	TRA
	Saudi Arabia	CITC
	Thailand	SDoC
	UAE	TRA
	Venezuela	TA
WiFi	Additional communication port used for + simultaneous WLAN automation to multiple devices and for QRATE Scanner 3000 series user interface connection + DHCP client or slave + internal or external antenna Certifications: North America IEC, IC, Europe CE mark, RBTTE WiFi may be continuous or activated as required by the following methods + through-the-glass gesture (walkup control) (QRATE Scanner 3100 only) + special function input (RTU control or external button) + Modbus command register Enhanced security to wired Ethernet and wireless ports Standard on QRATE Scanner 3300	

† Certification in combination with Scanner 3300 presently limited to North America and the EU.

QRATE SCANNER 3100 SERIES FLOW COMPUTER ORDERING CODES

For customer convenience in communicating product requirements to Sensia, the table below contains model codes for commonly requested features and options. Unique part numbers are generated for each feature combination. In some cases, the availability of a feature is contingent on other selections.

Code	Description				
3100	QRATE Scanner 3100 integrated control flow computer				
	Enclosure:				
X	Explosion-proof and weatherproof				
	Certification:				
X6	CEC and NEC Class 1 Div. 1 Groups C&D, Enclosure 4				
X9	CEC and NEC Class 1 Div. 1 Groups C&D, Enclosure 4, with provision for metrology seal wire				
XE	ATEX, IECEx II 2 GD Ex d [ia Ga] IIC T5 Gb or Ex tb [ia Da] IIIC T100 degC Db IP66 (Flame proof) Note: The enclosure is individually rated for IP 68 and Type 4X protection.				
	Direct mount multivariable transducer (MVT):				
00	None (brass conduit plug installed)				
X1	MVT with CRN—enclosure type 4				
HP	MVT, high pressure, no CRN				
	MVT materials and trim package: (Omit code when MVT is not required)	Pressure rating	Diaphragms	1/4-in national pipe thread taper (NPT) side ports	Bolts and nuts
A	Standard	ALL	316 SS	SS vent plug	Plated steel
C	SS bolting	≤ 3,000	316 SS	SS vent plug	316 SS
D	NACE (B7M not for offshore)	≤ 1,500	316 SS	316 SS pipe plug	B7M/2HM
E	NACE (Inconel bolting)	ALL	316 SS	316 SS pipe plug	Inconel 718
	MVT certificates and reports: (omit code when MVT documentation is not required)				
M	Mill test reports for MVT (significantly increases the price and delivery lead time)				
N	NACE certificate				
F	Full—NACE certificate with mill test reports for MVT				
	MVT process connections: (omit code when MVT is not required)				
LP	One set on bottom, for gas service, vertical piping				
SI	Two sets on each end, for liquid or steam service, horizontal piping (special order)				
	MVT ranges: (omit code when MVT is not required)				
0103	100 psi, 30 in H ₂ O				
0503	500 psi, 30 in H ₂ O	Special order			
0320	300 psi, 200 in H ₂ O				
0384	300 psi, 840 in H ₂ O				
0520	500 psi, 200 in H ₂ O				
1520	1,500 psi, 200 in H ₂ O				
1540	1,500 psi, 400 in H ₂ O				
1584	1,500 psi, 840 in H ₂ O				
3020	3,000 psi, 200 in H ₂ O				
3040	3,000 psi, 400 in H ₂ O	3,000 psi range with 316 SS bolts has a CRN safe working pressure limit of 2,725 psi.			
3084	3,000 psi, 840 in H ₂ O				
5320	5,300 psi, 200 in H ₂ O				
5330	5,300 psi, 200 in H ₂ O	5,300-psi range requires MVT code (HP) and has a CRN safe working pressure limit of 3,625 psi.			
5340	5,300 psi, 400 in H ₂ O	Single seal is limited to 3,000 psi.			
5384	5,300 psi, 840 in H ₂ O				
XX1K	> 300 psi, 1,000 in H ₂ O	Special order			
	Batteries:				
X	None				
8	Lithium—7.2 V DC battery pack. Restricts transportation methods. Battery pack may be shipped separately. Two battery packs per device. Not recommended for most applications. Required for MID certification compliance (pending)				
	Firmware:				
00S	Standard				
MC	Measurement Canada Approved				

(continued on next page)

QRATE SCANNER 3100 SERIES CONTINUED

Code	Description
	Explosion-proof switches (factory-mounted):
XX	None
RX	Momentary switch only (see diagram at right)
OX	Toggle switch only (see diagram at right)
R0	Momentary and toggle switch
	Switch lockout option (available with switch options RX, OX, and R0 only):
0	No lockout
1	With lockout
	SmartMesh wireless communications: (internal radio, explosion-proof-to-IS adapter for antenna)
00	None
A0	Radio with no antenna (antenna supplied separately by Sensia or other manufacturer)
A1	Radio with right-angle antenna (see diagram at right)
	WiFi wireless communications and enhanced network security
00	None
W0	With no external antenna (internal antenna behind faceplate)
W1	Explosion-proof to IS adapter but no external antenna (supplied as a separate line item or by others)
W2	With right-angle, direct-mount antenna (internal radio, explosion-proof to IS adapter)
	Explosion-proof conduit plugs: (unused conduit openings must have a plug)
B	Brass plugs
S	Stainless steel plugs

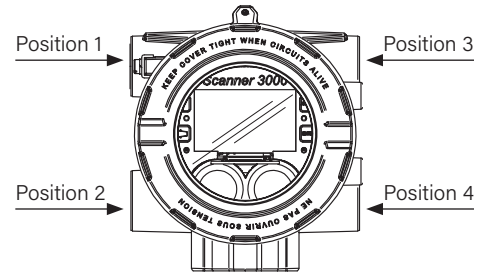

Mounting Location of Factory-Installed Options

SmartMesh antenna	Position 1
Toggle switch	Position 2
WiFi antenna	Position 3
Momentary switch	Position 4

DIMENSIONS AND WEIGHT

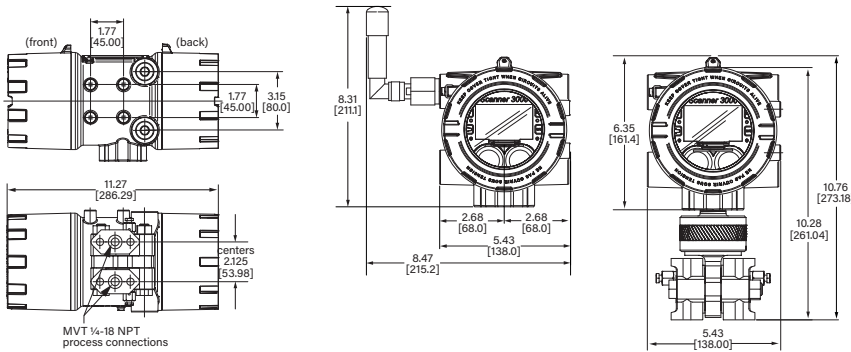

Dimensions, in [mm]

Weight, lbm [kg]	
QRATE Scanner 3100 base unit (no MVT, no batteries)	9.1 [4.1]
MVT	8.3 [3.8]
Batteries (2 stick-style battery packs)	1.1 [0.5]
Total weight (wired version) [†]	18.4 [8.3]
Direct-mount antenna and coupler (wireless)	0.6 [0.3]
Total weight (wireless version) [†]	19.0 [8.6]

[†] Includes MVT and batteries

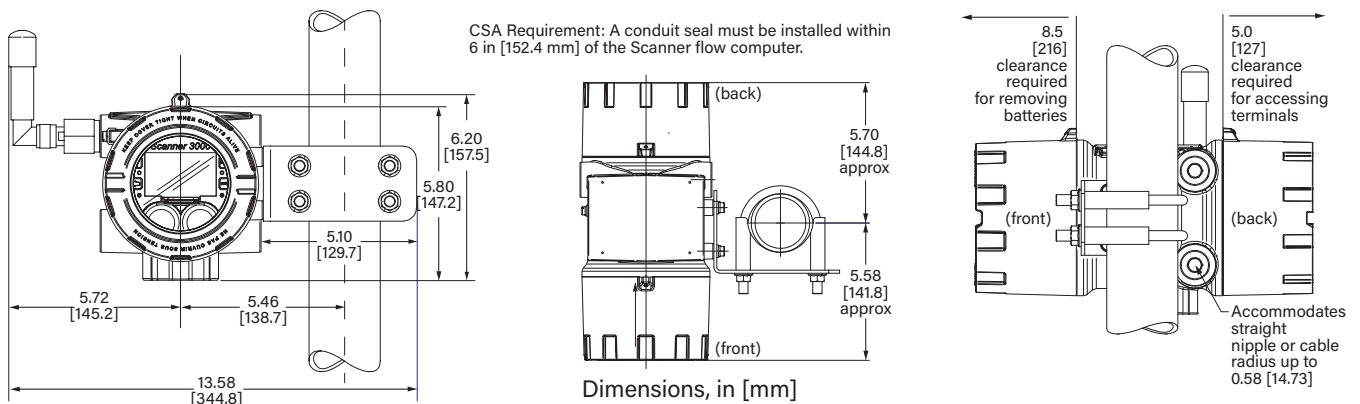

DIMENSIONS WITH POLE MOUNT

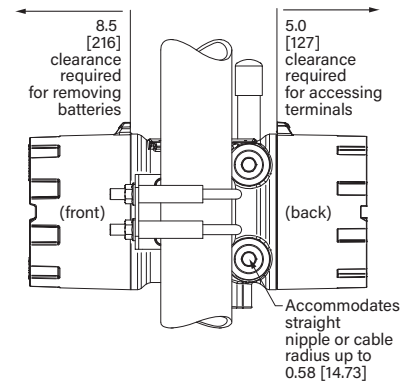

Dimensions, in [mm]



SCANNER 3100 HARDWARE OPTIONS

 <p>External antenna</p>	<p>Direct-mount antenna, omnidirectional, elbow connection, 3.75-in tall</p> <p>Remote-mount antenna, omnidirectional, straight connection, 3.85-in tall (cable sold separately by Sensia)</p> <p>N male brass nickel-plated connector for use with N female explosion-proof† or I.S. coupler, as shown</p> <p>10-ft, 20-ft, and 30-ft cable lengths with connectors for remote-mount antennas, Type 400, -40 to 70 degC [-40 to 158 degF]</p>
 <p>Control switch</p>	<p>Explosion-proof† switch, fits 3/4-in female pipe thread, momentary contact, or toggle action</p> <p>See Digital I/O>Special Functions on page 7 for application.</p>
 <p>Toggle switch</p>	<p>Toggle switch is available with or without lockout mechanism (shown) to prevent unauthorized changes to switch position.</p>
 <p>Pole mount kit</p>	<p>Stainless steel mounting kit for 2-in pole; mounts to side of the electrical enclosure</p>
<p>RTD temperature sensor</p>	<p>Consult local representative for various alternatives and configurations.</p>

SCANNER 3300 ORDERING INFORMATION

<p>QRATE Scanner 3300 with WiFi and internal antenna Part number 9A-EFM_3300_0001D</p>
<p>QRATE Scanner 3300 with WiFi and Smartmesh wireless Part number 9A-EFM_3300_0002D</p>
<p>Scanner 3300 accessories and components Consult local representatives for a variety of accessories and components including,</p> <ul style="list-style-type: none"> + antennas + 19" rack mounting + expansion input and output modules + meters and sensors + power or communication sub-systems

QRATE SCANNER 3300 DIMENSIONS

