

+ QRATE Scanner 3100



Integrated Control Flow Computer

Installation, Operation & Maintenance Manual



Important Safety Information

Symbols and Terms Used in this Manual

	WARNING	Identifies information about practices or circumstances that can lead to personal injury or death, property damage, or economic loss.
	AVERTISSEMENT	Un avertissement identifie des informations sur des pratiques ou des circonstances pouvant entraîner des blessures corporelles ou la mort, des dommages matériels ou des pertes économiques.
	CAUTION	Caution, risk of electric shock
	ATTENTION	Attention, risque d'électrocution
	CAUTION	Indicates actions or procedures which if not performed correctly may lead to personal injury or incorrect function of the instrument or connected equipment.
	Attention	Indiquez les actions ou les procédures qui, si elles ne sont pas effectuées correctement, peuvent entraîner des blessures ou un mauvais fonctionnement de l'instrument ou de l'équipement connecté.
	IMPORTANT	Indicates actions or procedures which may affect instrument operation or may lead to an instrument response which is not planned.
	Note	Indicates actions or procedures which may affect instrument operation or may lead to an instrument response which is not planned. Indique des informations supplémentaires sur des conditions ou des circonstances spécifiques pouvant affecter le fonctionnement de l'instrument.

Technical Support Contact Information

TEL: +1 844.226.6327
EMAIL: ms-services@sensiaglobal.com
WEB: <https://sensiaglobal.com/Measurement>

Revision History

Revision	Description of Change	Issuer	Approver	Date
5	Branding update from revision notes	KP		02/17/2021
6	Updated from revision notes	AK		03/22/2021

Table of Contents

Important Safety Information	ii
Section 1—Introduction	1
About the QRATE Scanner 3100 integrated control flow computer	1
Web Browser-Based Interface	1
Supporting Software and User Help Documents.....	1
Standard Features.....	2
Product Identification	2
Hardware Options.....	3
Sensors	3
Battery Packs	3
Explosion-Proof Control Switch.....	4
Explosion-Proof RTD Assembly	5
Flameproof RTD Assembly (ATEX, Zone 1).....	6
Pole-Mounting Kits	6
Wireless Communications.....	7
Restricting the Configuration	8
Physical Configuration Lock Switch	11
Specifications	13
Table 1.1—General Specifications	13
Table 1.2—Hardware Options	19
Table 1.3—Scanner Companion Software	20
Flow Rate and Fluid Property Calculations	21
Table 1.4—Flow Rate Standards.....	22
Table 1.5—Fluid Property and Energy Flow Calculations	23
Table 1.6—Flow Correction Factors.....	25
Section 2—Installing the QRATE Scanner 3100	27
Overview.....	27
Hazardous Area Precautions.....	27
ATEX Installations (Conditions for Safe Use).....	27
CSA Installations	28
Pressure Precautions.....	28
Table 2.1—MVT Materials and Bolt Specifications.....	28
Thermowell Location (for Gas and Liquid Flow Runs Only).....	29
Mounting Options	29
Pole-Mounting the QRATE Scanner 3100.....	30
Hazardous Area Requirements for WiFi and Wireless Communications	31
FCC Radio Frequency Compliance.....	32
IC Radio Frequency Compliance	33
Radio Frequency Compliance Labeling	33
Antenna Installation Options.....	34
Direct-Mount Antenna.....	34
Remote-Mount Antenna for Pole Outside Diameters up to 2 Inches.....	34
Remote-Mount Antenna for Pipe Outside Diameters of 2 3/8 Inches.....	35
Industry Standard Compliance	36
Table 2.2—Industry Standards for Meter Installation	36
Measuring Natural Gas via a Differential Pressure Meter	38
Best Practices	38
Direct Mount to Orifice Meter or Cone Meter	39
Remote Mount to Orifice Meter or Cone Meter	40
Measuring Natural Gas via a Turbine Meter.....	41
Best Practices	41
Remote Mount to a Turbine Meter.....	42
Measuring Steam via a Differential Pressure Meter	43
Best Practices	43
Installation Procedure—Remote Mount to Orifice Meter or Cone Meter.....	44

Measuring Liquid via a Differential Pressure Meter 47
 Best Practices 47
 Direct Mount to Orifice Meter or Cone Meter 48
 Remote Mount to Orifice Meter or Cone Meter 49
 Measuring Compensated Liquid via a Turbine Meter 51
 Best Practices 51
 Performing a Manifold Leak Test 52
 Zero Offset (Static Pressure or Differential Pressure) 52
 Static Pressure Calibration and Verification 53
 Differential Pressure Calibration and Verification 54
 Placing the Scanner into Operation 55

Section 3—Wiring the QRATE Scanner 3100 57

Field Wiring Connections 57
 Power Supply Wiring 59
 Internal Power Supply 59
 External Power Supply 60
 Input Wiring 61
 Turbine Flowmeter Inputs 61
 RTD Inputs 61
 Analog Inputs 62
 Pulse Inputs 62
 Digital Inputs—Contact Closure 63
 Digital Inputs—Pulse 64
 Digital Inputs—Open Collector 64
 Output Wiring 65
 Analog (4 to 20 mA) Outputs 65
 Digital Outputs 66
 Communications 67
 RS-485 Communications 67
 RS-232 Communications 67
 Ethernet Communications 68

Section 4—Connecting to the QRATE Scanner 3100 Web Interface 69

IP Address Options 69
 Connection Options 70
 Direct (1-to-1) Connection to a Laptop 70
 Ad-Hoc Wireless Router Connection 71
 Single-Port Router Option (Requires Wireless-Enabled Laptop) 71
 Multi-Port Router Option 72
 QRATE Scanner 3100 Network Connection 72
 WiFi Communications Accessory 73
 Installation 73
 Wiring the WiFi Box 75
 Connecting to the QRATE Scanner 3100 79
 Troubleshooting the Wireless Connection 79
 Adding Security to the WiFi Connection 79

Section 5—Display and Keypad Operations 81

IP Address 81
 Status Indicators (Glyphs) 81
 Table 5.1—Device Status Glyph Definitions 82
 Table 5.2—Parameter Status Glyph Definitions 83
 Configurable Display Features 83
 Message Display Mode 84
 Keypad Controls 84
 Table 5.3—Keyboard Controls 84
 LCD Display Indicator 85
 Viewing Communication Settings 85

Section 6—QRATE Scanner 3100 Maintenance..... 87
 Lithium Battery Pack Replacement 87
 Replacement Procedure..... 88

Section 7—QRATE Scanner 3100 Parts 89
 Spare Parts and Optional Hardware..... 89
 Table 7.1—QRATE Scanner 3100 integrated control flow computer Parts 89
 Table 7.2—Wireless Components 91
 Table 7.3—RTD and Cable Assemblies 92
 Electronics Replacement..... 92
 Table 7.4—QRATE Scanner 3100 Circuit Board Replacements..... 92

Appendix A—Lithium Battery InformationA-1
 Lithium Battery Disposal A-1
 Transportation Information A-1
 Battery Safety Datasheet..... A-1

Appendix B—FTP DownloadsB-1
 Downloading SDF Files from the QRATE Scanner 3100 B-1
 Slave Device Archive Logs B-2
 Viewing and Sharing Downloaded Data B-2

Appendix C—Firmware, Configuration, Scanner Logic, and Modbus Register Map Uploads.....C-1
 Firmware Uploads C-1
 Configuration Uploads C-1
 Register Map Uploads C-1
 ScanFlash Upload C-2

Appendix D—Measurement Canada ConfigurationD-1
 Physical Configuration Lock Switch..... D-2
 Device Physical Sealing Methods D-6
 Exporting User Event Records D-7
 Verification Triggering Events D-8
 Removing Verification Triggering Event..... D-8

This page intentionally left blank.

Section 1—Introduction

About the QRATE Scanner 3100 integrated control flow computer

The QRATE Scanner* 3100 integrated control flow computer is uniquely designed to serve as a stand-alone flow computer or as a network manager capable of collecting and storing data from up to 20 NUFLO Scanner 2000 Series flow computers. As a stand-alone flow computer, the QRATE Scanner 3100 offers dual flow stream and bidirectional measurement and control, as well as the processing power to handle the industry's most challenging flow computations for liquid and natural gas measurement. For operations requiring the monitoring of several measurement points, the QRATE Scanner 3100 combines up to 20 external wired or wireless NUFLO Scanner 2000 Series devices into a single scalable local area network that can be managed via a web browser-based interface. Each of the three serial ports can support multiple wired NUFLO Scanner 2000 Series devices or other external Modbus devices. Optional wireless communications significantly reduce installation costs and setup time and increase worker safety.

The device is explosion-proof and approved by for ATEX/IECEX Zone 1 hazardous area installations and for CSA Class I, Division 1 hazardous area installations. It is designed for use with a 9-30 VDC external power supply (9 to 24 VDC in Mexico installations) and two optional lithium battery packs for backup power.

The QRATE Scanner 3100 can be ordered with a multivariable transmitter (MVT) and paired with a cone or orifice meter for accurate measurement of liquids and natural gas. The Scanner device also computes the corrected (standard) amounts of fluid using signals from external turbine, positive displacement (PD), Venturi, Coriolis and ultrasonic flow meters and integral or remote pressure and temperature sensors. The measured fluids may be expressed as volume, mass or energy accumulations or rates. See [Table 1.4—Flow Rate Standards, page 21](#) and [Table 1.5—Fluid Property and Energy Flow Calculations, page 22](#) for a detailed description of supported calculations.

In addition to its two integral flow runs, the device supports 17 inputs and outputs and communications with chromatographs, samplers, and densitometers.

The device logs daily and hourly flow data for each flow run, and provides one-second triggered logging for analysis of critical events. High-speed communication via Modbus and Enron Modbus protocols makes it easy to integrate the QRATE Scanner 3100 into other measurement systems. When configured for use with Modbus master protocol, each of the device's three serial ports can log up to 128 data points from external Modbus devices.

For a complete list of specifications, see [Specifications, page 13](#).

Web Browser-Based Interface

A web browser-based interface equips you to configure flow runs, gas streams, and inputs/outputs, calibrate inputs, and view archive data from a laptop, tablet, smartphone, or other browser-enabled mobile device without installing software. You need only an Ethernet connection and an IP address to connect to the device. Four user security levels are available for customizing access for up to 20 users. An electronic user manual (PDF) is embedded in the interface, providing searchable on-screen help. To position the manual alongside the user interface for simultaneous viewing, configure your laptop per the instructions provided in the QRATE Scanner 3100 Web Interface User manual.

Supporting Software and User Help Documents

To experience the full range of the QRATE Scanner 3100's functionality, explore the complimentary software products and user documentation available on the Sensia website. See [Table 1.3—Scanner Companion Software, page 20](#) for more information.

IMPORTANT

To download software or user documentation, visit sensiaglobal.com/Measurement. Scroll to select **FLOW COMPUTING AND AUTOMATION**, then click **QRATE SCANNER 3000 SERIES INTEGRATED CONTROL FLOW COMPUTERS** and click the link for the desired software installation or user manual.

Standard Features

The QRATE Scanner 3100 features a double-ended explosion-proof enclosure with four conduit openings for inputs/outputs, a bottom conduit opening for a sensor, a large digital display, and a four-button keypad. Removing the front windowed cover provides access to batteries and the keypad. The rear cover is removed for field wiring. See [Section 3—Wiring the QRATE Scanner 3100, page 55](#) for wiring diagrams.

Product Identification

Each device is labeled with a serial tag that identifies the product by model number and serial number and identifies the maximum operating pressure, working pressure, and differential pressure of the integral MVT ([Figure 1.1](#)). The tag content depicted illustrates the electrical protection afforded by ATEX/IECEX certification. CSA-approved products are marked accordingly with the respective ratings and symbols.

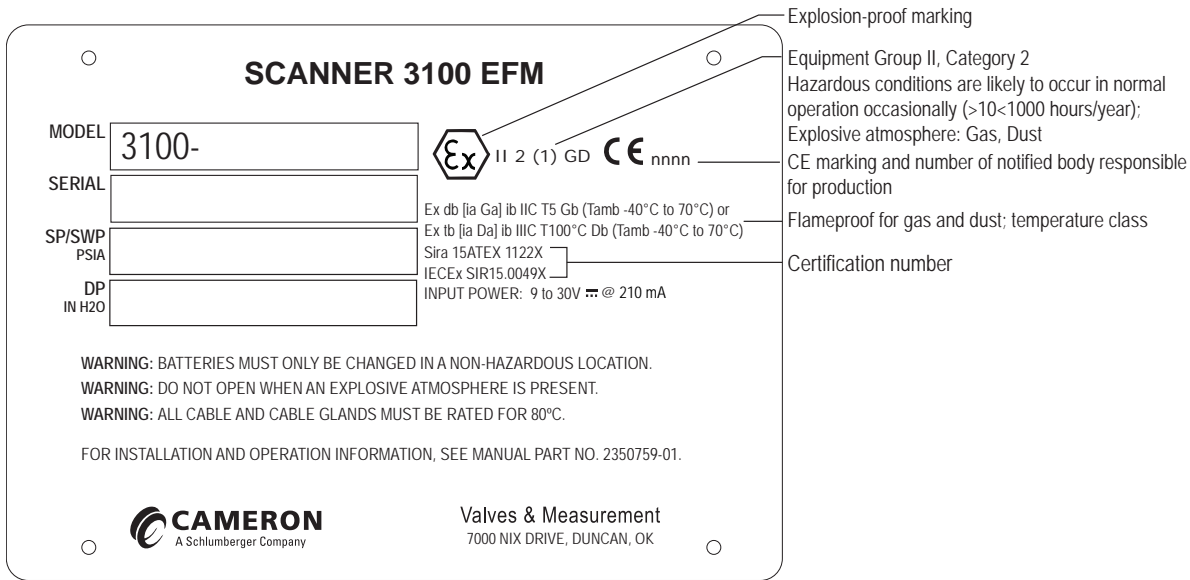

Figure 1.1—Device serial tags; ATEX tag

Hardware Options

The following hardware options are available for customizing the QRATE Scanner 3100 to your specific needs: sensors, battery packs, explosion-proof control switches, explosion-proof RTD assemblies, pole-mounting kits, and wireless communication components. See the sections below for details.

Sensors

The QRATE Scanner 3100 is available with no sensor or with an integral MVT (Figure 1.2). MVTs are available in NACE and non-NACE models with bottom ports (gas measurement) or side ports (liquid measurement).

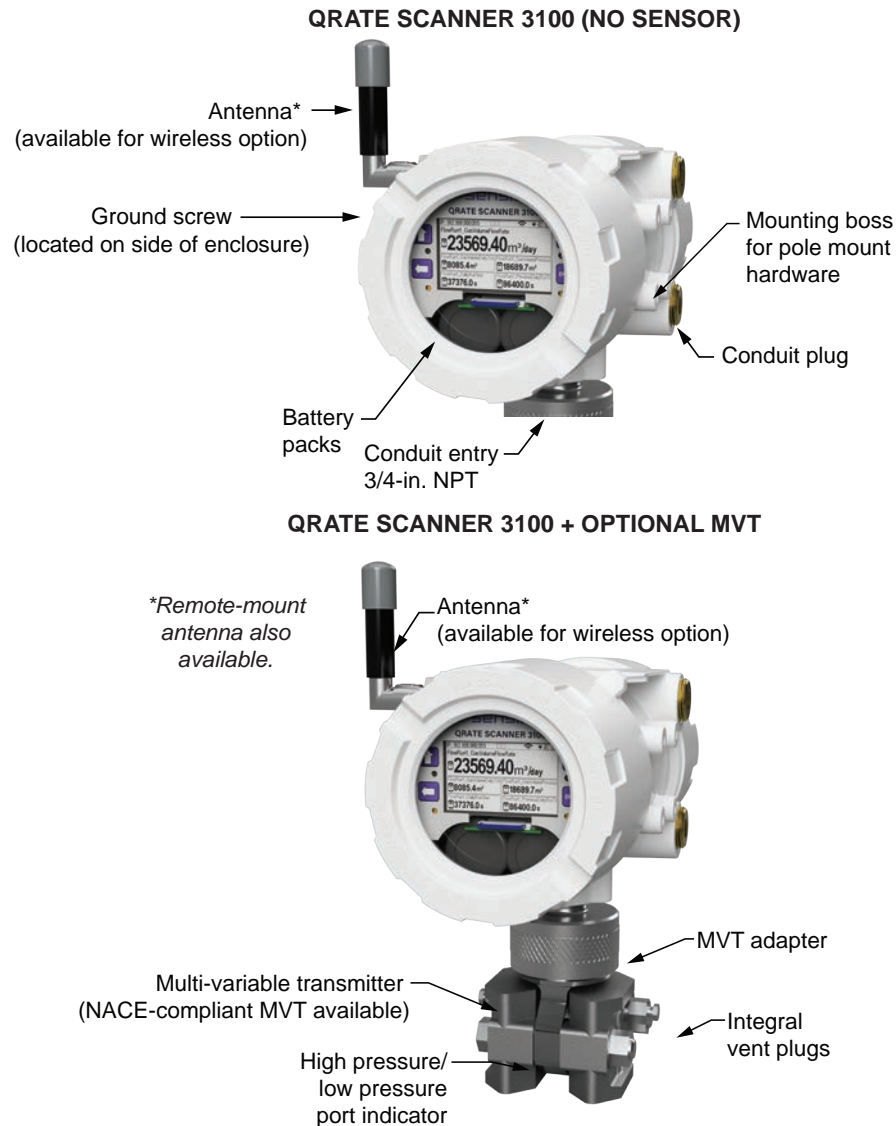

Figure 1.2—QRATE Scanner 3100 sensor options

Battery Packs

Sensia’s dual lithium battery packs (Figure 1.3, page 4) provide backup power for the QRATE Scanner 3100. Battery life can vary significantly depending on the input and output configurations in use. For continuous operation, an external primary power supply is required (9 to 30 VDC at 210 mA; for Mexico installations, use 9 to 24 VDC at 210 mA).

**WARNING**

EXPLOSION RISK. Housing temperature must not exceed 70 °C (158 °F). Excessive temperatures, which could result from ambient conditions combined with radiated and conductive heat from the process, could cause the internal lithium battery to ignite or explode.

Each stick-style battery pack contains two 3.6 V batteries. Together, the dual packs can autonomously power the device for a short period (approximately 2 to 3 weeks with a default configuration) in the event of a primary power outage. With dual packs installed, you can replace a depleted battery pack without interrupting operations even when the device is operating solely on battery power.

For more information on battery replacement, see [Lithium Battery Pack Replacement, page 85](#).

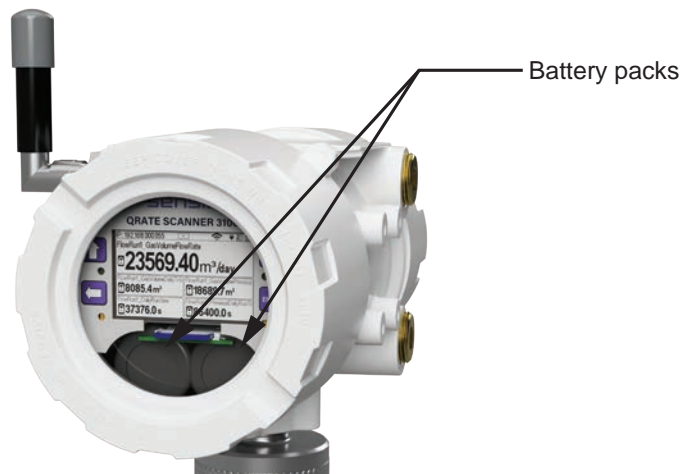

Figure 1.3—Lithium stick-style battery packs

Explosion-Proof Control Switch

An external explosion-proof control switch ([Figure 1.4](#)) allows you to manually control the operation of a peripheral device (such as a radio), unlatch an alarm, or reset a total being accumulated by the device, depending on how it is configured. The switch is available in either of two models:

- **Toggle Switch.** Opens or closes a circuit with each push and release of the button. Uses include manual control of flow accumulation, and manual control of a triggered archive.
- **Momentary Switch.** Opens or closes a circuit when the button is pushed and held in position. Unlike the toggle switch, the switch action is terminated upon release of the button. Uses include pacing the display, toggling a wireless transmitter on and off, resetting grand totals for flow run or pulse input accumulations, unlatching a digital output, and resetting a latch on a triggered archive.



Figure 1.4—Explosion-proof control switch (left); control switch with factory-installed safety lockout device (right)

Control switches are wired and pre-configured at the factory (Figure 1.5) when they are purchased with the device. However, you can change the configuration via the web interface. A momentary switch is connected to DIO Terminal 5 at the factory, and a toggle switch is connected to DIO Terminal 6. See [Digital Inputs—Contact Closure, page 61](#) and [Digital Outputs, page 64](#) for wiring diagrams.

Either switch is available with a factory-installed mechanical lockout device (Figure 1.4, page 4, right) that can be used with a lock or a seal to prevent unauthorized changes to the switch position as is sometimes required for audit compliance.

IMPORTANT	When a mechanical lockout device is required, the lockout must be installed in the switch at the factory. A lockout mechanism cannot be added to an existing device control switch after the switch is installed.
-----------	---

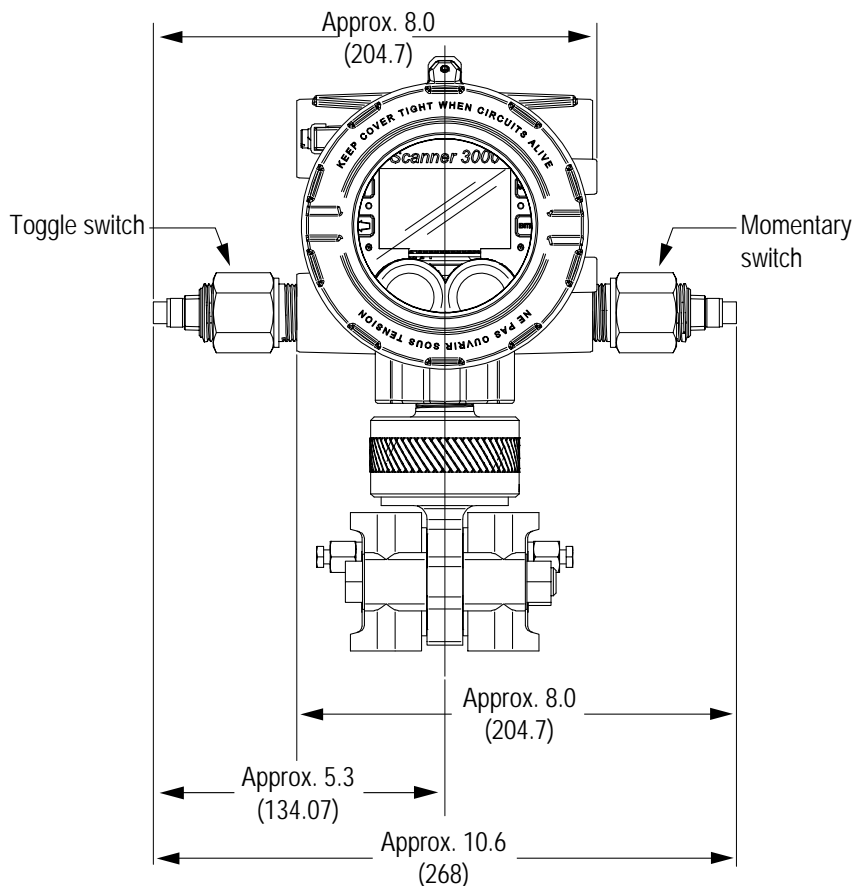

Figure 1.5—Control switch dimensions in inches (mm); the above diagram shows the default locations of factory-installed switches

Explosion-Proof RTD Assembly

The Barton Model 21 RTD, shown in Figure 1.6, page 6, is a 4-wire, 100-ohm explosion-proof RTD assembly that can be connected to the QRATE Scanner 3100 without conduit in a Class I, Division 1 installation. Factory-sealed, armored leads are covered in PVC. The RTD assembly can be ordered with teck cable lengths of 5, 10, or 30 ft, and is available with a 6-in. or 12-in. RTD probe.

The Model 21 RTD is CSA certified for use in Class I, Groups B, C, and D; Class II, Groups E, F and G; and Class III hazardous area environments.

Each RTD assembly is fitted with 1/2-in. and 3/4-in. connectors for adapting to various size conduit openings and threadollets. The RTD is field-adjustable for insertion lengths of up to 12 in. For wiring instructions, see Figure 3.6, page 59. For part numbers, see Table 7.3—RTD and Cable Assemblies, page 90.

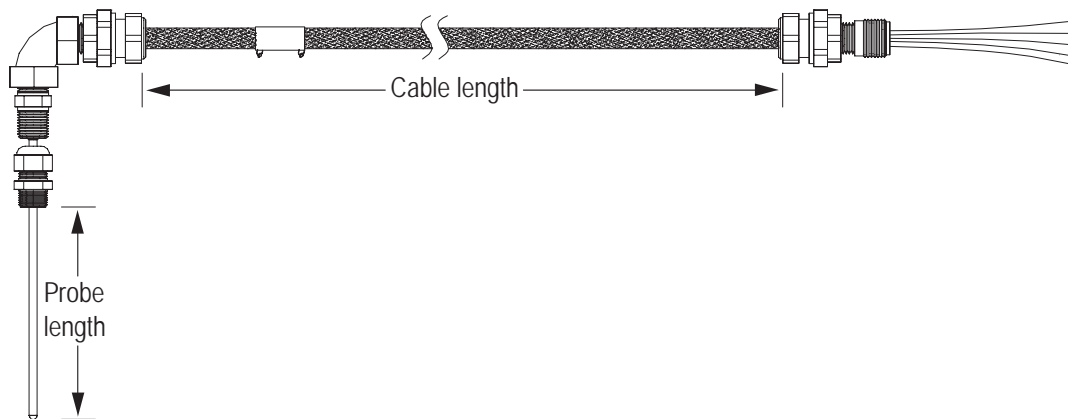

Figure 1.6—Explosion-proof (Class I, Div. 1) RTD assembly

Flameproof RTD Assembly (ATEX, Zone 1)

Sensia offers a flameproof RTD that is ATEX-certified for use in Zone 1 installations. The 4-wire, Class A sensor is encapsulated in a stainless steel sheath long enough to accommodate line sizes from 2 to 12 inches. It is attached to a 3500-mm armoured cable. For wiring instructions, see [Figure 3.6, page 59](#). For part numbers, see [Table 7.3—RTD and Cable Assemblies, page 90](#).

Pole-Mounting Kits

Sensia's pole mounting kit ([Figure 1.7](#)) is recommended for mounting a QRATE Scanner 3100 to a 2-in. pole. The kit consists of a stainless steel "L" mounting bracket, two U-bolts, and four 10-mm M6 screws.

The bracket bolts directly to the four mounting bosses on the side of the Scanner enclosure and the U-bolts secure the assembly to the pole. For installation instructions, see [Pole-Mounting the QRATE Scanner 3100, page 28](#). For part numbers, see [Section 7—QRATE Scanner 3100 Parts, page 87](#).



Figure 1.7—Pole mounting kit

Wireless Communications

The QRATE Scanner 3100 wireless communications option includes factory-installed WiFi and SmartMesh wireless radio modules and couplers (Figure 1.8) that enables an external antenna to be safely used in a hazardous area.

Explosion-proof Coupler

An explosion-proof coupler is factory-installed in the top left conduit opening of the QRATE Scanner 3100 enclosure and the coupler cable is factory-connected to the radio module inside the enclosure. The coupler is rated for compliance with CSA (North America) or ATEX certification requirements. See Table 7.2—Wireless Components, page 89 for replacement part numbers.

Direct-Mount Antenna

The Sensia-supplied right-angle antenna (Figure 1.8) connects directly to the threaded coupler connection on the bottom right hand corner of the enclosure. When installing the antenna, ensure that it is in a vertical position well above ground level and positioned away from large structures that could interfere with signal transmission and reception.

Sensia's direct-mount antenna is rated for a maximum of 1 watt of power and a maximum antenna gain of 1.6 dB (in North America) and has a frequency range of 2.35 to 2.60 GHz. Antennas with equivalent ratings may also be used with the coupler.

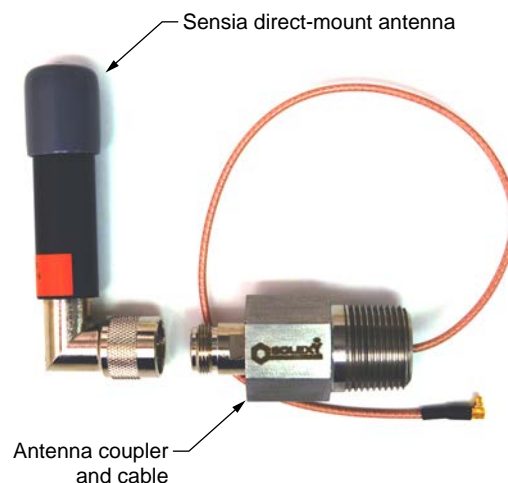

Figure 1.8—Direct-mount antenna and explosion-proof antenna coupler (left); the coupler cable is factory-connected to the QRATE Scanner 3100 enclosure

SmartMesh Remote-Mount Antenna

In locations where a physical barrier restricts the use of a direct-mount antenna or where a longer transmission distance is required, a remote-mount antenna (Figure 1.9, page 8) may be installed up to 30 ft (10 m) away and connected by cable to the antenna coupler. A remote-mount antenna and connecting cable may be purchased from Sensia (see Section 7—QRATE Scanner 3100 Parts, page 87). If purchasing cable elsewhere, verify that the cable meets the maximum capacitance and inductance ratings (Figure 2.5, page 30) and that the cable length is adequate to connect to both the antenna and the coupler. See Specifications, page 13 for additional details.

The installation of the antenna coupler, antennas, and antenna cable must meet the requirements shown in Figure 2.4 and Figure 2.5, page 30. For installation instructions, see:

- Remote-Mount Antenna for Pole Outside Diameters up to 2 Inches, page 32
- Remote-Mount Antenna for Pipe Outside Diameters of 2 3/8 Inches, page 33



Mounting hardware supplied with the Sensia remote-mount antenna (fits pole outside diameters up to 2 inches)



Optional hardware kit for mounting the Sensia remote-mount antenna to a 2-in. pipe (fits outside diameter of 2 3/8-in.)

Figure 1.9—SmartMesh remote-mount antenna mounting options

Restricting the Configuration

It may be necessary to lock the configuration so that there cannot be any changes made. In the case of Measurement Canada the device must have the configuration locked and the lids sealed such that tampering is not permitted, see table below:

Firmware Versions	Reference Section
3.040 - 3.069	For Measurement Canada configuration (i.e. firmware version is 3.040 - 3.069), refer to Appendix D—Measurement Canada Configuration, page D-1 .
All other firmware versions	Continue configuration in the following pages.

For the QRATE Scanner 3100 there is a physical configuration lock switch that may be engaged (set toward the front of the Scanner) which will lock the configuration, and then the user may use the web interface to determine the configuration locking mode. To access the Configuration Lock settings use the following steps:

1. Navigate to the **ADMINISTRATION** menu by **DEVICE>ADMINISTRATION>GENERAL** (see [Figure 1.10](#)).



Figure 1.10—QRATE Scanner 3100 Web Interface directions to Device Status screen

- The **ADMINISTRATION** menu will appear. Click **SECURITY** to navigate to the **SECURITY CONFIGURATION** menu (see Figure 1.11).



Figure 1.11—QRATE Scanner 3100 Web Interface Administration menu

- The **SECURITY** menu will appear. Click button **MODIFY** and then click button beside Configuration Lock Mode (see Figure 1.12).



Figure 1.12—QRATE Scanner 3100 Web Interface Security menu

4. The Configuration Lock Mode will appear (see [Figure 1.13](#)).

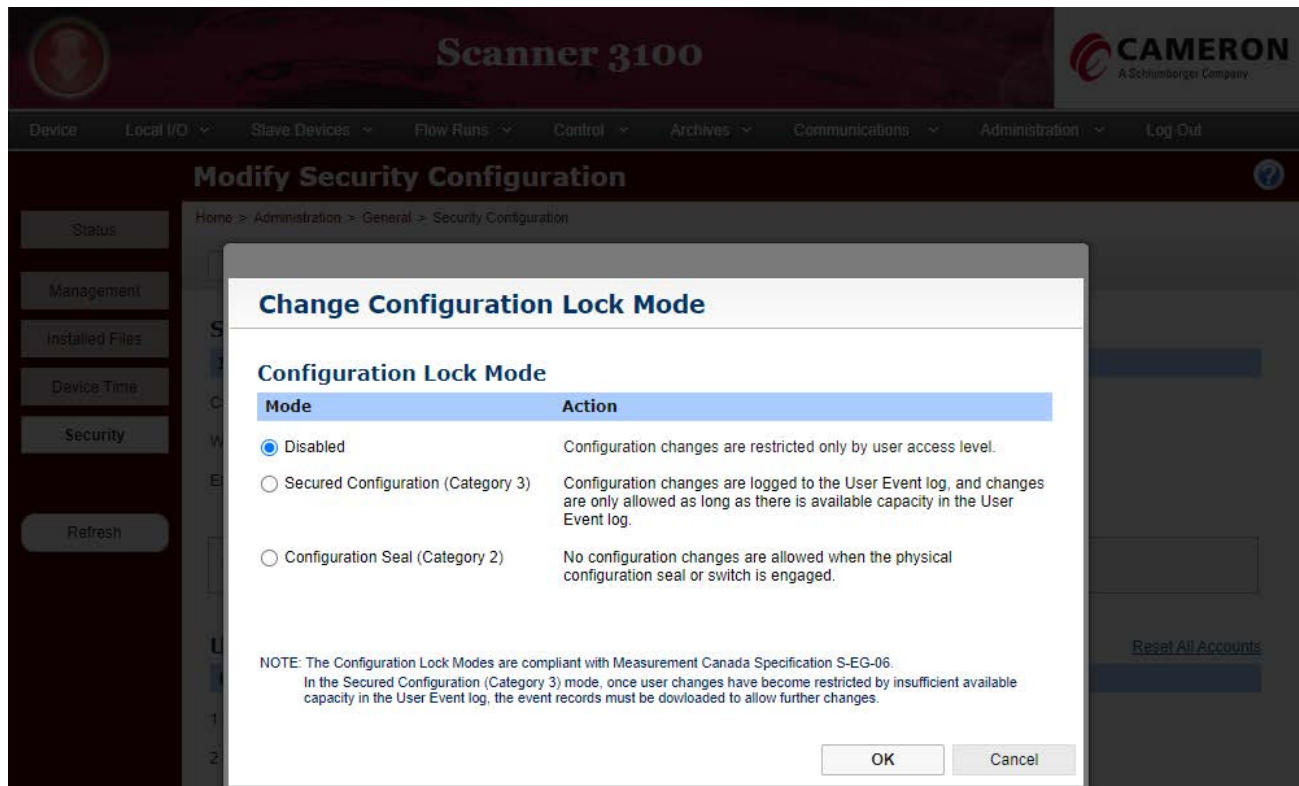

Figure 1.13—QRATE Scanner 3100 Web Interface Configuration Lock Mode

The configuration locking modes are as follows:

- **Disabled.** - Regardless of the position of the Physical Configuration Lock switch, the configuration changes will be restricted by user access level only.
- **Secured Configuration (Category 3)**
 - Must be enabled in the software interface.
 - The configuration is secured by an event logger.
 - If 1000 or less unused or previously exported User Event records (out of a total of 81,920 user event records), and no configuration changes are permitted. Lock glyph is displayed as closed.
 - If More than 1000 unused or previously exported User Event records (out of a total of 81,920 user event records), and configuration changes are permitted. Lock glyph is displayed as open.
 - Verification Triggering Events (VTEs) are supported.
- **Configuration Seal (Category 2)**
 - Must be enabled in the software interface.
 - The Physical Configuration Lock switch determines if configuration is locked (no changes permitted). **Switch is engaged (set toward the front of the Scanner).** No configuration changes are permitted. Lock glyph is displayed as closed.
Switch is disengaged (set toward the back of the Scanner). The configuration is not locked and configuration changes are permitted.

Note

For Secured Configuration (Category 3):

Verification Triggering Events (VTEs) are enabled, and will show on the LCD if there is a change to a legally relevant metrological parameter.

User changes will be restricted when the User Event log becomes nearly full, and the event records must be downloaded to allow further changes.

It is not possible to freely erase User Event change log records. Log records may only be overwritten after a user with sufficient permissions exports the log to an external memory, including date and time of intervention.

This is compliant with Measurement Canada Specification S-EG-06.

For Configuration Seal (Category 2):

Verification Triggering Events (VTEs) are disabled.

Physical Configuration Lock Switch

The Physical Configuration Lock switch is located inside the QRATE Scanner 3100 housing along the top edge of the display circuit board assembly, just left of center (Figure 1.15). If a Configuration Lock Mode has been software enabled, the switch may be engaged (set toward the front of the Scanner) to activate the mode and restrict or prevent configuration of the device. Details for each mode on page 10.

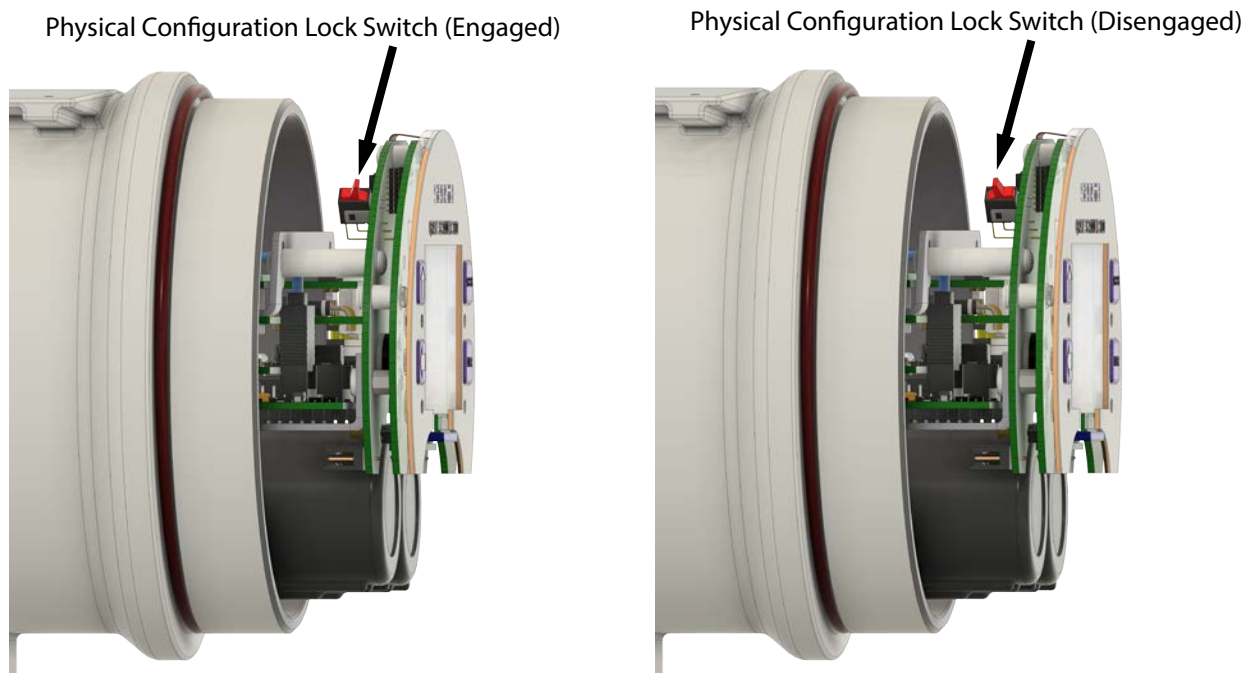

Figure 1.14—Physical Configuration Lock switch; Engaged (left); Disengaged (right)

The position of the Physical Configuration Lock switch may be verified (i.e. that the switch has been fully engaged) by observing the LCD display. When the switch has been fully engaged a Lock Glyph will be displayed. Otherwise, no lock glyph will appear.

When the locked lock glyph appears, no configuration changes may be made, until the seal has been broken and the Physical Configuration Lock switch has been disengaged.

When the unlocked lock glyph appears, configuration changes may still be made (as per the description on [page 10](#)).

When no lock glyph appears on the LCD, the configuration changes will be allowed, and restricted by user access level only.

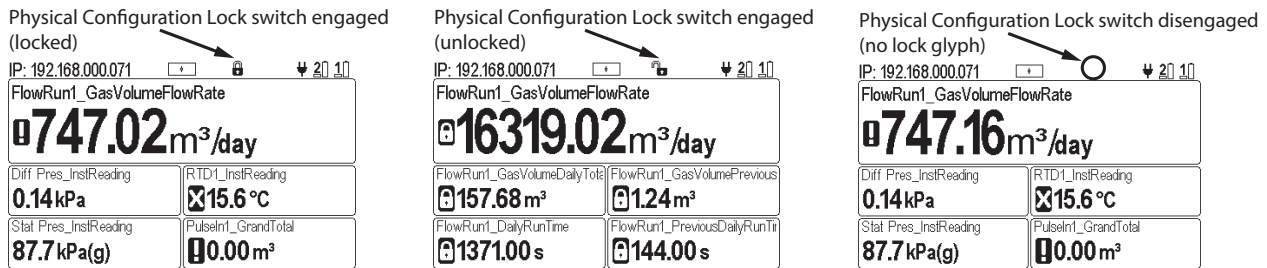

Figure 1.15—The presence of the Lock Glyph indicates that the Physical Configuration Lock switch is engaged, and position (locked or unlocked) indicates if configuration changes are locked

Specifications

Table 1.1—General Specifications	
Approvals	CSA (US and Canada) Class I, Div. 1, Groups C and D, T4; Type 4 enclosure
	ATEX 15ATEX1122X— Ex d [ia Ga] ib IIC T5 Gb (Tamb –40 °C to 70 °C; –40 °F to 158 °F) IECEX SIR 15.0049X— Ex tb [ia Da] ib IIIC T100 °C Db (Tamb –40 °C to 70 °C; –40 °F to 158 °F) (IP66 protection from dust and water)
	ANSI 12.27.01 single seal (MVT ≤ 3000 psi)
	ASME pressure vessel code (MVT ≤ 3000 psi); CRN 0F10472.5C
Environmental Safety	Relative humidity: 0% to 95% non-condensing
	Altitude: Up to 2000 meters
Enclosure	Cast aluminum (less than 0.05% copper), painted with epoxy and polyurethane
	Double-ended with single window
	Dimensions: 5.43 in. wide, 11.27 in. deep, 10.76 in. tall with MVT
	5 conduit ports including bottom sensor port, 3/4-in. FNPT connections
Weight	<i>Base unit (no MVT or batteries)</i> 4.1 kg (9.1 lb)
	<i>Base + MVT and 2 batteries</i> 8.3 kg (18.4 lb)
	<i>Base + MVT, direct-mount antenna, and 2 batteries</i> 8.6 kg (19 lb)
System Power	External user-supplied power supply (9 to 30 VDC, 210 mA) with internal lithium battery backup. For installations in Mexico, the power supply is limited to 9 to 24 VDC.
	Two integral 7.2 V lithium stick-style battery packs, each containing two “D” batteries in series (air transport regulations apply)
Real-time Clock	Accurate within 2 minutes/year over temperature range
	Lithium coin cell battery maintains clock during loss of system power (lithium content: 0.11 g)
Processor	32-bit dual-core ARM Cortex M4
Operating Temperature	–40 °C to 70 °C (–40 °F to 158 °F)
	LCD contrast is reduced below –30 °C (–22 °F)
 WARNING EXPLOSION RISK. Housing temperature must not exceed 70 °C (158 °F). Excessive temperatures, which could result from ambient conditions combined with radiated and conductive heat from the process, could cause the internal lithium battery to ignite or explode.	
LCD Display/ Keypad	2.7-in. diagonal graphic display, 400 × 240 pixels
	0.3-in. high characters
	Displays up to 32 user-defined parameters (five at a time), with auto-scrolling
	External power indicator
	Integral battery capacity indicators
	Wireless communications indicator
	Parameter status indicators
	Configurable background (dark or light) and scroll frequency
4-button keypad for advancing the display; viewing communication settings, serial number, and firmware version; and restoring factory default settings to the device	
Memory	2.18 MB RAM for processing
	512 KB non-volatile memory for configuration data
	32+1 MB on-board system flash memory
	48 MB on-board archive flash memory

Table 1.1—General Specifications

Supported Meter Types	Turbine meter		
	Cone meter		
	Orifice meter		
	Ultrasonic meter		
	Positive displacement (PD) meter		
	Coriolis meter		
	Venturi meter		
Download Types	<i>Per Device</i>	Complete (all records, including slave device records as applicable) Local (integral flow records in a condensed file ideal for emailing) Events Triggered (one-second logs, including PID tuning)	
	<i>Per Flow Run</i>	Daily Interval (hourly) Event Recent (past 7 days of interval logs)	
	<i>Per Slave</i>	Daily Interval (hourly) Recent (past 7 days of interval logs)	
Archive Capacity	Up to 58 archivable parameters per flow run		
	<i>Daily log capacity</i>	2,048 days	
	<i>Interval log capacity</i>	2.8 years with 13 parameters (plus date, time and status) logged hourly Capacity varies with the number of parameters logged (13 to 58) and logging frequency (1 second to 12 hours)	
	<i>Triggered log capacity (1 to 19 parameters)</i>	1,351,680 logs with one parameter logged; 135,168 logs with 19 parameters logged Configurable to log periodically (1 second to 12 hours) on a real-time period (daily, weekly, etc.) on device alarm, on digital input, or when activated remotely via the web browser	
	<i>Event/Alarm Record Capacity</i>	81,920 records	
	<i>User Change Records Capacity</i>	81,920 records	
	Downloadable via FTP, HTTP (web interface), or Enron Modbus protocol (see Scanner Data Manager User Manual for information on viewing data files)		
	Logs stored in non-volatile memory for up to 10 years		
Communications/ Archive Retrieval	<i>Wireless</i>	<i>WiFi</i>	WiFi radio module available with right-angle antenna. WiFi and Ethernet together support up to two TCP/IP user-configurable ports with selectable slave protocols.
		<i>SmartMesh</i>	Optional SmartMesh wireless radio module available with or without external antenna. See SmartMesh Radio, page 19 .
	<i>Wired RS-485</i>	Two dedicated ports (1 and 2) and one shared RS-485/RS-232 port (3)	
		Software-selectable 120-ohm termination resistor	
		Selectable master and slave protocols (Enron Modbus, Modbus RTU, Modbus TCP)	
	<i>Wired RS-232</i>	Shared RS-485/RS-232 port (port 3)	
TXD, RXD, RTS, CTS			
Time-of-day digital output configuration			

Table 1.1—General Specifications		
Communications/ Archive Retrieval (cont'd)	<i>Ethernet/TCP</i>	One RJ-45 connection supports two TCP/IP user-configurable ports with selectable slave protocols
		Continuous use requires external power
		Supports 10/100 Mb/s
	<i>Port Pass-Through</i>	Any communications port can be routed to another port
		Ethernet can be bridged to serial communications for remotely interfacing with connected Modbus devices. (For example, a Scanner slave device can be configured using ModWorX* Pro software without changing wiring connections.)
Flow Rate Calculations	<i>Natural Gas</i>	AGA 3 (1992 and 2012), ISO 5167-2 (2003), ISO 5176-5, ASME MFC-14M (2003), AGA-7 (includes scope of AGA 11)
	<i>Liquids</i>	API MPMS 5.3, AGA 3, ISO 5167, AGA 7
Fluid Property Calculations	<i>Natural Gas</i>	AGA-8 part 1&2 (includes scope of AGA 10), AGA-3, AGA-5, GPA 2145-09, IF-97, ISO 6976
	<i>Liquids</i>	API MPMS Chapter 11.1 (2004)
	<i>Pure Substances</i>	IAPWS-IF97 (Steam) Quality-corrected saturated steam (Regions 4)
		IAPWS-IF97 (Steam-Water) Auto-selected Region saturated steam, water, dry steam, critical range (Regions 1 through 4)
Liquid Compensation and Correction Factors	Temperature and pressure compensation	
	Meter factor compensation	
	Shrinkage factor compensation	
	Live BS&W correction	
	Live density correction	
	Dynamic oil fraction (watercut)—derived from flowing density or watercut analyzer; automatic base density updates from flowing density measurement	
	Chisholm-Steven orifice meter multiphase correction for steam	
	Chisholm-Steven cone meter multiphase correction for steam	
Flow Streams	Two integral compensated flow run inputs	
	Up to 20 remote flow runs via NUFLO Scanner 2000 Series devices in local area Scanner network	
	Three additional integral uncompensated pulse/frequency inputs	
	Bidirectional flow measurement	
	Up to 8 gas streams using gas chromatograph inputs or user-entered static compositions	
	16-point calibrations for all inputs (linear factory and multipoint meter factor calibrations also supported); see Table 1.6—Flow Correction Factors, page 24 for information on multipoint meter factor calibration	
	Stacked differential pressure and static pressure inputs for rangeability	
MVT Specifications	Linearized digital data for static pressure (absolute) and differential pressure	
	Measures pressure in absolute and displays pressure in gauge	
	Standard MVT has bottom ports, which are ideal for gas measurement; MVT can be inverted for liquid measurement (LCD autocorrects for easy viewing)*	
	Complies with pre-qualified materials of NACE MR0175/ISO 15156. <i>This certification does not imply or warrant the application of the product in compliance with NACE MR0175/ISO 15156 service conditions in which the customer/user installs the product.</i>	
	Process temperature: –40 °C to 121 °C (–40 °F to 250 °F)	
	User-adjustable sample time (up to 10 Hz) and damping	
	*Side-port MVT for liquid measurement is available by special order.	

Table 1.1—General Specifications				
MVT Accuracy	<i>Differential Pressure</i>	± 0.05% of range for all except for 30 "H2O ± 0.1% of range for 30 "H2O		
	<i>Static Pressure</i>	± 0.05% of range		
	<i>Temperature Effect</i>	± 0.25% of full scale over operating range		
	<i>Stability (long-term drift)</i>	Less than ± 0.05% of URL per year over a five-year period		
	<i>Resolution</i>	24 bits		
	Effect on Differential Pressure for a 100-psi Pressure Change			
		Differential Pressure Range (in. H2O)	Zero Shift (% URL)	Span Shift (% reading)
		± 30*	.05	.01
		± 200**	.01	.01
		± 400	.04	.01
	± 840	.04	.01	
<i>*± Indicates bidirectional capabilities (for example, a range of 30 in. H2O is -30 to +30 H2O).</i>				
<i>**Exception: 200 x 300 psi has a zero shift of .007% and a span shift of .01%.</i>				
MVT Pressure Ranges	Static Pressure/SWP (psia)	Differential Pressure (in. H2O)	Maximum Overrange Pressure (psia)	
	100	30	150	
	300	200 or 840	450	
	500	30 or 200	750	
	1500	200, 400, or 840	2250	
	3000	200, 400, or 840	4500	
	5300	200, 400, or 840	7420	
	<i>Custom ranges available by special order. For materials of construction, see Table 2.1—MVT Materials and Bolt Specifications, page 26.</i>			
Analog Inputs	4 channels			
	1 to 5 V, 0 to 5 V, 4 to 20 mA, or 0 to 20 mA			
	Accuracy: ± 0.030% of span maximum error at 25 °C (77 °F)			
	Temperature effect: ± 0.25% of span over operating range			
	Impedance: > 60 Kohm for 1 to 5 V input; approximately 250 ohm for 4 to 20 mA input			
	Transmitter voltage supply: 10 VDC at 20 mA, protected to 50 mA			
	Over-voltage protection: 30 VDC			
	A/D resolution: 22 bits (minimum 20 effective bits)			
	Linearity error: ± 0.020% max.; ± 0.010% typical			
	Single-ended inputs			
	Sample rate: 0.1 seconds to 12 hours			
	Four previous calibrations available stored in device			
	Configurable shutoff for saving power when transducer warm-up period is not required			
	Integral battery backup			

Table 1.1—General Specifications

RTD Inputs	2 channels	
	100-ohm platinum RTD with 2-wire, 3-wire, or 4-wire interface	
	Range: -40 °C to 427 °C (-40 °F to 800 °F), excluding RTD uncertainty	
	Accuracy: ± 0.2 °C (0.36 °F) over sensing range at calibrated temperature	
	Temperature effect: ± 0.3 °C (0.54 °F) over operating range	
	A/D resolution: 24 bits	
	Sample rate: 0.1 seconds to 12 hours	
	Configurable shutoff for power savings when transducer warm-up period is not required	
Pulse/Frequency (TFM) Inputs	3 channels	
	Maximum voltage: 30 VDC	
	Maximum frequency: 10,000 Hz	
	Gated transmitter power for each input channel	
	Transmitter voltage supply: 10 VDC at 20 mA, protected to 50 mA	
	TFM Channel 3 has no sleep mode and increased power consumption	
	Accumulation types: uncompensated gas volume, uncompensated liquid volume, mass	
	Volume: pulse represents discrete units of volume from a turbine, PD, Venturi, Coriolis, or ultrasonic meter	
	Mass: pulse represents discrete units of mass from a Coriolis meter	
	Configurable turbine sensitivity (20, 50, 100 mV, peak-to-peak)	
Analog Outputs	2 channels	
	Type 4 to 20 mA, optically isolated, externally powered	
	Accuracy (after calibration): ± 0.1% of span maximum error at 25 °C (77 °F)	
	Temperature drift: ±50 ppm/°C (±27.8 ppm/°F)	
	Maximum output load resistance (ohms) = {supply (volts) - 8.0} / 0.02	
	Maximum voltage: 30 VDC	
	D/A resolution: 16 bits	
	Calibration (zero and full-scale) via software	
	Programmable output alarm value for use during loss of power or communication to CPU	
	Regulates control valve in PID control applications	
Digital I/O	6 channels, user-configurable as input or output	
	DIO1, DIO2, DIO3, and DIO4 are optically isolated with a max. output of 60 mA at 30 VDC	
	DIO5 and DIO6 are high-speed and non-isolated with a max. output of 500 mA at 30 VDC	
	Input Types	Control switch
		Pulse
		Open collector
		Contact closure
	<i>Special Functions</i>	Advance display
		Turn SmartMesh on/off
		Reset specific flow run total
		Reset specific pulse input total
		Unlatch specific digital inputs/output
		Acknowledge alarms
Start or refresh WiFi		
Publish triggered archive record		

Table 1.1—General Specifications		
Digital I/O (cont'd)	<i>Special Functions (cont'd)</i>	Release triggered archive latch
		Create partial archive
		Abort script program
		Reset script program
	Output Modes	Pulse (based on pulse count or time period)
		Alarm (based on the status of any or all selected alarms; up to 32 user-configured alarms are selectable)
		Conditional (value above or below setpoint, out of setpoint range)
		Programmed [time of day or output state (normally open, normally closed)]
		Configurable to track any value including PID Control applications
	<i>Pulse Output</i>	Maximum frequency: 50 Hz
		Configurable pulse duration (10 msec to 1 day)
		Configurable pulse representation (1 pulse = 1 MCF) based on time or volume
		Based on any accumulator (flow run or turbine meter run)
	<i>Alarm Output</i>	Low/high
		Out-of-range
Status/diagnostic		
Web Interface—Local Device Management	Access data and device settings via laptop, tablet, or smartphone	
	Configure, calibrate, and maintain flow runs, inputs/outputs, and gas streams	
	Poll real-time data	
	Download data	
	View daily logs and up to 7 days of interval (recent) logs	
	Control user access with four levels of security	
Web Interface—Network Management	Configure communications with up to 20 wired or wireless NUFLO Scanner 2000 Series devices	
	Display real-time data, flow rate calculation method, and input averages for up to 20 slave devices	
	Read and store configuration data from up to 20 slave devices	
	Read and store daily and interval archive records for up to 20 slave devices	
	Change gas composition and plate size in slave device configurations	
	Download slave data via FTP, HTTP, or Enron Modbus protocol	
	Synchronize slave device configuration and slave archive data	
	Read gas streams connected to slave devices	
	Clear slave device grand totals and alarms	
	Load factory default configuration file	
	Remotely reset slave device without cycling power	

Table 1.2—Hardware Options			
Wireless SmartMesh Radio	2.4 GHz self-healing and self-sustaining network		
	Factory installed with stainless steel, explosion-proof antenna coupler, N female × 3/4 MNPT, with 12-in. coaxial cable and MMCX male connector		
	Transmits up to 300 m (985 ft) node-to-node		
	Supports communications with up to 20 remote NUFLO Scanner 2000 Series devices (each Scanner node can transmit and receive data)		
	Radio certifications (by country): Europe: CE Mark, RED North America: FCC/IC		
WiFi Module	28 mm x 38 mm, Wi-Fi enabled Linux module, 0.5 W power consumption		
	802.11 b/g/n, 2.4 GHz, 1x` SISO, 150 MBs max data rate, 21 dB output power		
	16 MB Flash, 64 MB DDR2 RAM		
	U.FL connector or external pin for external antenna		
	WiFi range is 50 meters		
Antenna	Direct-Mount		Remote-Mount
	Electrical Properties		
	Frequency Range	2.35 to 2.50 GHz	2.4 to 2.5 GHz
	Impedance	50 ohms nominal at 2.4 GHz	50 ohms nominal at 2.4 GHz
	Voltage Standing Wave Range (VSWR)	1.13:1	<1.5
	Connector	N male brass nickel-plated connector for use with N female explosion-proof/intrinsically-safe coupler	N female brass nickel-plated connector, cable required for connection to N female explosion-proof coupler
	Height	95.25 mm (3.75 in.)	800 mm (32.28 in.)
	Shape	Elbow (right angle)	Straight
	Material	UV-resistant ABS	Fiberglass
	Operating Temperature	−40 °C to 80 °C (−40 °F to 176 °F)	−40 °C to 80 °C (−40 °F to 176 °F)
	Pole Mount Hardware		
	—	N/A	Standard hardware (included with antenna) fits pole with outside diameter up to 2 in.
	—	N/A	Alternate remote-mount kit available for pipe with outside diameter of 2 3/8 in.
	Antenna Cable	Length	N/A
Type		N/A	Type 400
Temperature Range		N/A	−40 °C to 70 °C (−40 °F to 158 °F)
Control Switch (CSA- or ATEX-Approved)	Explosion-proof switch*, momentary contact, fits 3.4 in. female pipe thread (uses include pacing the display, toggling a wireless transmitter on and off, resetting flow run or pulse input grand totals, unlatching a digital output, and resetting a triggered archive latch)		
	Explosion-proof switch*, toggle action, fits 3.4 in. female pipe thread (uses include manual control of flow accumulation and manual control of a triggered archive)		
	*Switch can be ordered with a factory-installed mechanical lockout mechanism for preventing unauthorized users from changing the switch position.		
Remote-Mount Kit	Stainless steel mounting kit for 2-in. poles (mounts to the side of the electrical enclosure)		

Table 1.2—Hardware Options

RTD Temperature Sensor	4-wire, 100-ohm explosion-proof RTD assembly suitable for CSA Class 1, Div. 1 installations
	4-wire, Class A sensor encapsulated by a stainless steel sheath and attached to a 3500 mm (11.48 ft) armoured cable
Thermowell	Nominal 6.6 mm (0.26 in.) bore, 1/2-in. FNPT instrument connection
	Consult factory for various materials, process connections, insertion lengths, and options
5-Valve Manifold	Consult factory for direct-mount or remote-mount manifold and materials
Portable Ethernet Router	Supports connection of a PC or other browser-based device to a QRATE Scanner 3100 Integrated Control Flow Computer. Connects to Scanner with RJ-45 cable and connect to PC via WiFi. Available in USB- or battery-powered models. See Wireless Communications, page 7 for additional WiFi solutions.
Customer Tag	Stainless steel tag for customer-specified information, 3 in. × 3 in., wired on, 5 lines of text, 45 character per line maximum

Table 1.3—Scanner Companion Software

IMPORTANT	To download software or user documentation, visit sensiaglobal.com/Measurement . Scroll to select FLOW COMPUTING AND AUTOMATION , then click QRATE SCANNER 3000 SERIES INTEGRATED CONTROL FLOW COMPUTERS and click the link for the desired software installation or user manual.
Scanner Logic IDE	Creates Scanner Logic scripts (SLOGIC) and compiles them into a logic-controller program file (SLBIN).
	Performs live debugging on scripts, showing immediate and upcoming script sections to be debugged.
	Uses a high-level procedural programming language designed to build logic controllers. In this way, the program resembles a state machine.
Scanner Data Manager	Opens proprietary data files (.sdf) downloaded from the device and provides tools for data analysis, reporting, export and conversion
	Presents data in tabular and trend views
	Includes tools for customizing reports
ScanMap	Creates custom QRATE Scanner 3100 Modbus register maps, including user-specified units, rates, and register names for SCADA integration
	Firmware-specific templates
	Auto-generates protocol manual for printing or uploading to the web interface
ScanFlash	Uploads firmware (BIN), configuration (SRF), Scanner Logic IDE file (SLBIN), and custom Modbus register map (PMAP) files to the QRATE Scanner 3100
PC Requirements	
Windows 7 or later operating system	
1 GHz or faster 32-bit (x86) or 64-bit (x64) processor	
1 GB RAM (32-bit) or 2 GB RAM (64-bit) available hard disk space (135 MB for companion software installation, 30 MB for Adobe Reader, adequate space for data files)	
DirectX 9 graphics device with WDDM 1.0 or later driver	

Flow Rate and Fluid Property Calculations

The QRATE Scanner 3100 calculates flow rates and fluid properties for natural gas and liquid flow in accordance with the following industry standards. The calculations compensate for the effects of pressure, temperature, and fluid composition to determine mass and volume at specified base conditions. The fluid corrections typically require configuration of inputs including static pressure and temperature. The flow calculation requires configuration of differential pressure or pulse (frequency) inputs.

Table 1.4—Flow Rate Standards

Standard	Description	Orifice	NuFlo Cone	Linear Pulse Output	Venturi
AGA 3 (1992)	The QRATE Scanner 3100 supports the orifice metering calculations described in AGA Report No. 3 (1992). This meter covers pipe sizes of nominal 2-in. and larger; there is no stated maximum limit, but the largest size listed in the standard is nominal 36 inch. Beta ratio must lie between 0.1 and 0.75. The AGA 3 orifice meter can be used to measure natural gas and liquids.	◆			
AGA 3 (2012)	The QRATE Scanner 3100 supports the orifice metering calculations described in AGA Report No. 3 (2012). The AGA 3 orifice meter covers pipe sizes of nominal 2-in. and larger; there is no stated maximum limit, but the largest size listed in the standard is nominal 36-in. Beta ratio must lie between 0.1 and 0.75. The 2012 report offers an improved expansion factor correction and is recommended for use except where contractual or regulatory requirements specify the 1992 standard. The AGA 3 orifice meter can be used to measure natural gas and liquids.	◆			
ISO 5167-2 (2003)	ISO 5167-2 describes the measurement of natural gas and liquids with an orifice meter using pipe sizes of nominal 50 mm (2 in.) to a maximum of 1000 mm (39 in.). Beta ratio must lie between 0.1 and 0.75. In ASME MFC-3M (2004), the ISO-5167 orifice flow calculation was adopted without modification. The ISO orifice meter can be used to measure natural gas and liquids.	◆			
ISO 5167-4 (2003)	ISO 5167-4 provides information for calculating flow rates with Venturi tubes. It is applicable only to Venturi tubes in which the flow remains subsonic throughout the measuring section and where the fluid can be considered as single-phase. In addition, each of these devices can only be used within specified limits of pipe size, roughness, diameter ratio and Reynolds number. ISO 5167 4 is not applicable to the measurement of pulsating flow. It does not cover the use of Venturi tubes in pipes sized less than 50 mm or more than 1200 mm, or for where the pipe Reynolds numbers are below 20000.				◆
ISO 5167-5 (2016)	ISO 5167-5 specifies the geometry and method of use (installation and operating conditions) of cone meters when they are inserted in a conduit running full to determine the flow rate of the fluid flowing in the conduit.		◆		
ASME MFC-14M (2003)	For low flow applications, the QRATE Scanner 3100 supports the small bore orifice described in ASME MFC-14M for use with nominal 1/2-in. to 1-1/2-in. pipe sizes. Beta ratio must lie between 0.1 and 0.75. The ASME small bore orifice meter can be used to measure natural gas and liquids.	◆			
AGA 7 (2006)	AGA 7 provides the measurement standards used to calculate natural gas flow rates from linear pulse output meters, including turbine meters, vortex shedding meters, pulser-equipped positive displacement (PD) meters, Coriolis meters having volumetric pulse output, and other types. Linear pulse output meters can be used to measure natural gas and liquids.			◆	
Miller Handbook, Third Ed.	Richard Miller’s Flow Measurement Engineering Handbook provides definitive information on selecting, sizing, and performing pipe-flow-rate calculations, using ISO and ANSI standards in both SI and US equivalents. This reference also presents physical property data, support material for important fluid properties, accuracy estimation and installation requirements for all commonly used flow meters.				

Table 1.5—Fluid Property and Energy Flow Calculations

Standard	Description	Natural Gas	Hydrocarbon Liquid	Steam
AGA 5 (2009)	AGA 5 provides the methods for computing the mass, molar, and volumetric heating values of natural gas at reference temperature. AGA 5 is also used in calculating related properties, including Wobbe index, motor octane number, and net (inferior) volume heating value. <i>AGA 5 supports an intermediate calculation and therefore is not a standard fluid property selection in the QRATE Scanner 3100 web interface.</i>	◆	◆	
AGA 8, Part 1, Detailed (2017)	<p>The worldwide standard for calculating the physical properties of natural gas and similar gases is the AGA 8 92DC equation originally described in AGA Report No. 8 (1992). The 2017 edition, Part 1, uses the same DETAIL equations of state as in the 1994 edition of AGA 8. However, the temperature, pressure, and gas composition limits have been modified in this edition.</p> <p>Use of this calculation requires a gas analysis, i.e. knowledge of the mole fractions of 21 gas components: the alkanes methane through decane, common diluents including nitrogen, carbon dioxide, hydrogen sulfide, and assorted trace components. In ISO 12213-2 (1997), the AGA 8 92DC equation was adopted without modification.</p> <p>The AGA 8 92DC equation is most accurate between temperatures of 17 °F and 143 °F (–8 °C to 62 °C) and at pressures up to 1,750 psia (12 MPa). If lesser accuracy is acceptable, the range can be extended from –200 °F to 400 °F (–130 °C to 200 °C) and pressures up to 20,000 psi (140 MPa). This fluid calculation will provide the computed value for Speed of Sound.</p>	◆		
AGA 8, Part 1, Gross (2017); SGerg-88 (1988)	When the detailed composition of the gas is unknown, an alternative method of characterizing the gas is available. It is based on the gross properties: real gas relative density (gas gravity), and content of carbon dioxide and nitrogen. This method detailed in AGA 8 and ISO 12213-3 is based on the SGerg-88 equation. The Gross Characterization method should only be used at temperatures between 17 °F and 143 °F (–8 °C to 62 °C) and at pressures below 1,750 psia (12 MPa). Gravity range is from 0.554 to 0.87; up to 28.94% carbon dioxide, and up to 53.6% nitrogen. This method should not be used outside of these limits.	◆		
AGA 8, Part 2 (2017); Gerg-2012	AGA 8, Part II uses temperature, pressure, and gas molar composition to compute fluid density at base and flowing conditions. AGA 8, Part II is used with a flow calculation to determine fluid flow rate.	◆		
API MPMS Chapter 11.1 (2004)	The temperature and pressure correction factors for hydrocarbon liquids including crude oil, refined products (gasoline, jet fuel, fuel oils), lubricating oils, and special products are calculated according to API MPMS Chapter 11.1 (2004). For crude oils, the density range is 610.6 to 1,163.5 kg/m ³ , temperature range is from –58 °F to 302 °F (–50 °C to 150 °C), and pressure range is from 0 to 1,500 psig (0 to 10,340 kPa). For differential pressure meters, the viscosity at operating temperature is a required input to the flow computer, and it must be determined as accurately as possible.		◆	
API MPMS Chapter 20.1 (2011)	API MPMS Chapter 20.1, Section 1.9.5.4, provides procedure for computing net oil volume in an oil/water mixture when watercut is higher than normal and a dynamic sampling method, such as an online watercut analyzer, is used to measure watercut, incorporating a shrinkage factor where applicable.		◆	
GPA 2145 (2008)	GPA 2145 is a compilation of numerical values for the paraffin hydrocarbons and other compounds occurring in natural gas and natural gas liquids as well as for a few other compounds of interest to the industry. <i>GPA 2145 supports an intermediate calculation and therefore is not a standard fluid property selection in the QRATE Scanner 3100 web interface.</i>	◆		

Table 1.5—Fluid Property and Energy Flow Calculations

Standard	Description	Natural Gas	Hydrocarbon Liquid	Steam
ISO 6976 (2016)	ISO 6976 specifies methods for the calculation of the superior calorific value and the inferior calorific value, density, relative density and Wobbe index of dry natural gas and other combustible gaseous fuels, when the composition of the gas by mole fraction is known. <i>A simplified version of the AGA 5 calculation, ISO 6976 supports an intermediate calculation and therefore is not a standard fluid property selection in the QRATE Scanner 3100 Web Interface.</i>	◆		
IAPWS-IF97, Saturated Steam	IAPWS Industrial Formulation 1997 for the Thermodynamic Properties of Water and Steam. This calculation should be used when the steam is assumed to be at the saturation temperature at a given flowing pressure. Only a pressure input is required. Providing a steam quality measurement will yield an estimated liquid flowrate and produce accumulations for vapor and liquid water.			◆
IAPWS-IF97, All Regions	IAPWS Industrial Formulation 1997 for the Thermodynamic Properties of Water and Steam. This calculation should be used when measuring in regions off the saturation line operating conditions and when the water is liquid or super-heated. A pressure input and a temperature input are required. From the flowing condition inputs, the operating region of the water is detected: liquid water (Region 1), dry steam (Region 2), critical range (Region 3), and saturated steam (Region 4). All regions except liquid water are accumulated as vapor.			◆

Flow Correction Factors

The QRATE Scanner 3100 measures compensated petroleum liquid flow using an orifice or cone flow meter. For accuracy, these measurements often include a correction factor to compensate for the effect of gas or water on volume, or changes in calibration. [Table 1.6](#) describes the correction factors configurable in the QRATE Scanner 3100 web interface.

Table 1.6—Flow Correction Factors

<i>Flow Correction Factor</i>	<i>Description</i>
Multipoint Meter Factor Correction (for Gas and Liquid)	The multipoint meter factor calibration method allows users to compensate for variations between calibrations without changing the meter K-factor from the value stamped on the meter at the factory. Meter factors are typically determined through calibrations performed by third-party test laboratories. You can enter the appropriate factor during calibration to account for any variation in the calibration curve over Reynolds numbers.
Chisholm-Steven Orifice Meter Multiphase Correction (for Steam)	The Chisholm-Steven correction method is used for over-reading prediction in wet vapor flow conditions (multiphase) for water at the flowing conditions along the saturation line. When provided with a quality measurement, the vapor flow is corrected and the estimated liquid flow is accumulated.
Crude Oil Shrinkage Factor	This correction factor allows users who are measuring crude oil to automatically correct their liquid volume measurements for the effects of gas content. When the oil is discharged from a pipeline to a stock tank at atmospheric conditions, the volatile components in the oil evaporate, causing a reduction in liquid volume. When live oils are metered (e.g., test separators), a shrinkage factor must be applied to correct the measured liquid volume from the metering pressure and temperature to stock tank conditions unless the meter is proved to stock tank conditions. Shrinkage volumes are typically obtained with a shrinkage tester. This correction method will correct the meter reading for both dissolved gas and for oil volume reduction. It will not compensate for the effects of fluid viscosity changes. Shrinkage volumes or factors are often used to mitigate safety and environmental concerns when live oil volumes are measured at high pressures or when the live oil contains hydrogen sulfide (H ₂ S).
Base Sediment and Water (BS&W) Correction Factor	Crude oil generally contains some water. The BS&W correction provides a means of discounting the water content and totalizing only the crude. The correction can be based on a user-entered value (assumed to be constant) or on a watercut monitor/BS&W monitor output to the QRATE Scanner 3100 via a 4-20 mA signal.

Section 2—Installing the QRATE Scanner 3100

Overview

The QRATE QRATE Scanner 3100 Integrated Control Flow Computer is fully assembled at the time of shipment and ready for mounting. However, Sensia recommends that operators configure the device prior to mounting if the instrument is to be installed in a hazardous area. The enclosure must be opened to configure the device, either via keypad controls or via software, and once the instrument is mounted in a hazardous area, the cover should not be removed unless the area is void of combustible gas and vapors.

Hazardous Area Precautions

The QRATE Scanner 3100 is ATEX/IECEx-certified (Zone 1) and CSA-certified (Class I, Div. 1) for hazardous area use. Installation requirements vary, depending on the certification required. Carefully review the following hazardous area requirements before installing the device in a hazardous area.

ATEX Installations (Conditions for Safe Use)

The ATEX-certified standard QRATE Scanner 3100 is fully compliant with European ATEX Directive 2014/34/EC and has been evaluated per the following standards (Dates of standards are available in the Certificate of Conformity):

- IECEx: IEC 60079-0, Edition 6, IEC 60079-1, Edition 6, IEC 60079-11, Edition 6, and IEC 60079-31, Edition 2
- ATEX: EN 60079-0, EN 60079-1, EN 60079-11, EN 60079-31

The following instructions apply to equipment covered by certificate numbers Sira15ATEX 1122X and IECEx SIR 15.0049X:

- When splitting the conduit union to fit the data transfer socket to the communication adaptor and during data transfer, the user/installer shall ensure that no explosive atmosphere is present. After data transfer has finished, the conduit union shall be re-assembled in accordance with the relevant Code of Practice.
- Under rated conditions, the branching point at the entry point may reach 80°C, therefore, when choosing cables and cable glands this shall be taken into account.
- When removing or replacing the internal battery packs, this shall be done in accordance with the user instructions provided by the manufacturer, and the user/installer shall ensure that no explosive atmosphere is present.
- Some external parts of products that have an aluminium housing are non-conducting and may generate an ignition-capable level of electrostatic charges under certain extreme conditions. The user should ensure that the equipment is not installed in a location where it may be subjected to external conditions (such as high-pressure steam) which might cause a build-up of electrostatic charges on non-conducting surfaces. Additionally, cleaning of the equipment should be done with a damp cloth.
- Flameproof joints are not intended to be repaired by the user.
- The outer of the coax radio frequency connector is earthed at the enclosure. In a remote antenna installation using coax cable the antenna shall therefore be installed on an isolated earth support to ensure a single earth connection only in the antenna circuit.

RTD Assembly Options (for Gas and Liquid Flow Runs Only)

The process temperature input is typically supplied by an RTD installed in a thermowell downstream of the primary differential pressure source. The location of the thermowell should conform to the relative standard to ensure accurate measurement. Use only an RTD assembly that is fitted with a suitably certified, Ex d IIC cable entry gland, such as the flameproof RTD (Part No. 9A-X-TTXR-0003) listed in [Section 7—QRATE Scanner 3100 Parts, page 87](#).

CSA Installations

The QRATE Scanner 3100 is CSA-certified as explosion-proof for Class I, Division 1, Groups C and D hazardous locations.

Wiring Precautions



CAUTION

All field wiring must conform to the National Electrical Code, NFPA 70, Article 501-4(b) for installations within the United States or the Canadian Electric Code for installations within Canada. Local wiring ordinances may also apply. The cable used between the QRATE Scanner 3100 and other devices must be either armored MC-HL cable or standard cable routed through conduit. If standard cable is used, a conduit seal must be installed within 6 inches of the Scanner.

Pressure Precautions



WARNING

Before connecting the QRATE Scanner 3100 to a flow line, consider the pressure rating of the sensor and the presence of harmful gases. The tubing and fixtures used to connect the sensor to the manifold in the flow line must be manufactured from materials that are appropriate for the pressure ratings of the sensor used. If H₂S is present, use a NACE sensor and take appropriate precautions to avoid exposure to this hazardous gas.

Table 2.1—MVT Materials and Bolt Specifications

<i>MVT Materials of Construction</i>	
Process Cover	316 SS (other materials available by special order)
Process Cover Gasket	Glass-filled PTFE
Diaphragm	316L SS (other materials available by special order)
Vent/drain	SS bleed (316SS plug optional for NACE and coastal applications)

<i>Body Bolts and Nuts (non-process wetted)</i>					
	B7/2H ① alloy steel	B7M/2HM ① alloy steel	316SS ②	17-4 PH SS	Inconel 718
Configuration					
Standard	Yes	No	Yes	Yes	Yes
NACE	No	Yes	No	No	Yes
Coastal	Yes ①	Yes ①	Yes	No	Yes
Max. Pressure Range	5300 ③ ④	1500	1500	3000	5300
Coating	Plated	Black oxide	None	None	None

¹ B7 and B7M alloy steel is susceptible to rust. Other materials may be preferred for offshore use.

² 316 SS bolts have a CRN safe working pressure limit of 2725 psi.

³ 5300-psi ranges require transducer code HP and have a CRN safe working pressure limit of 3625 psi. Single seal is limited to 3000 psi.

⁴ 5300-psi ranges require transducer code HP and are not available with a Canadian CRN. 5300-psi range has a CRN SWP limit of 3710 psi. Therefore, it is possible to measure to 3710 psi and remain in CRN compliance. Single seal is limited to 3000 psi.

Note A four-port MVT adapter has been evaluated by CSA for use with the QRATE Scanner 3100 but is not released for production at this time. Seals must be installed at each port for CSA compliance. The four-port MVT adapter has not been evaluated for ATEX approval.

Thermowell Location (for Gas and Liquid Flow Runs Only)

The process temperature input is typically supplied by an RTD installed in a thermowell downstream of the primary differential pressure source using a 2-wire, 3-wire, or 4-wire RTD assembly. To ensure accurate measurement, the location of the thermowell should conform to the appropriate standard.

Mounting Options

The QRATE Scanner 3100 can be mounted using the following methods:

- **Direct-mount to an orifice or cone type differential pressure meter.** The MVT shown in [Figure 2.1](#) (with antenna in [Figure 2.3, page 29](#)) may be connected to the pressure taps with stabilizers or a heavy wall nipple with adapter flanges, and a 5-valve manifold. A bottom-port MVT is recommended for gas measurement; a side-mount MVT is recommended for liquid measurement.
- **Pole-mount.** The instrument can be mounted on a 2-in. pole using the mounting bosses on the side of the enclosure and a Sensia pole mount kit (as shown in [Figure 2.2, page 28](#)). Tubing is used to connect the MVT to the orifice meter or cone meter.

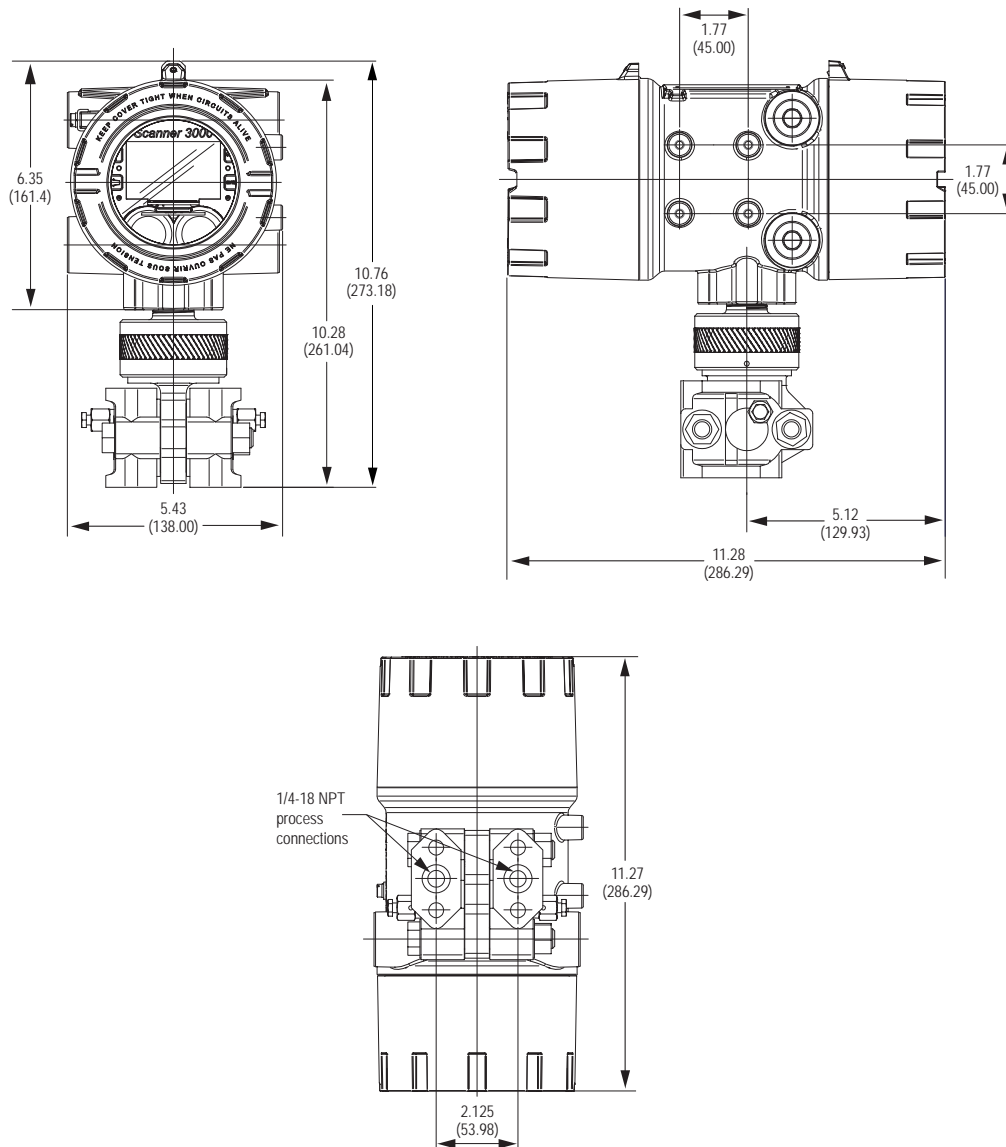

Figure 2.1—QRATE Scanner 3100 with MVT, direct-mount; dimensions shown in inches (mm)

The following accessories are also recommended:

- 5-valve manifold for connecting process lines to the MVT
- RTD assembly for process temperature input on gas flow runs and compensated liquid flow runs
- Tubing and/or pipe for plumbing process connections
- Explosion-proof signal cable for remote turbine connections (stranded, shielded cable is recommended)

Pole-Mounting the QRATE Scanner 3100

The 2-in. pole mount hardware kit (Figure 2.2) is a convenient option for remote-mounting the QRATE Scanner 3100. The kit consists of a stainless steel “L” mounting bracket with four mounting holes, two U-bolts, four nuts, and four 10-mm M6 screws.

CSA Requirement: When using standard cable, a conduit seal must be installed within 6 in. (152.4 mm) of the Scanner.

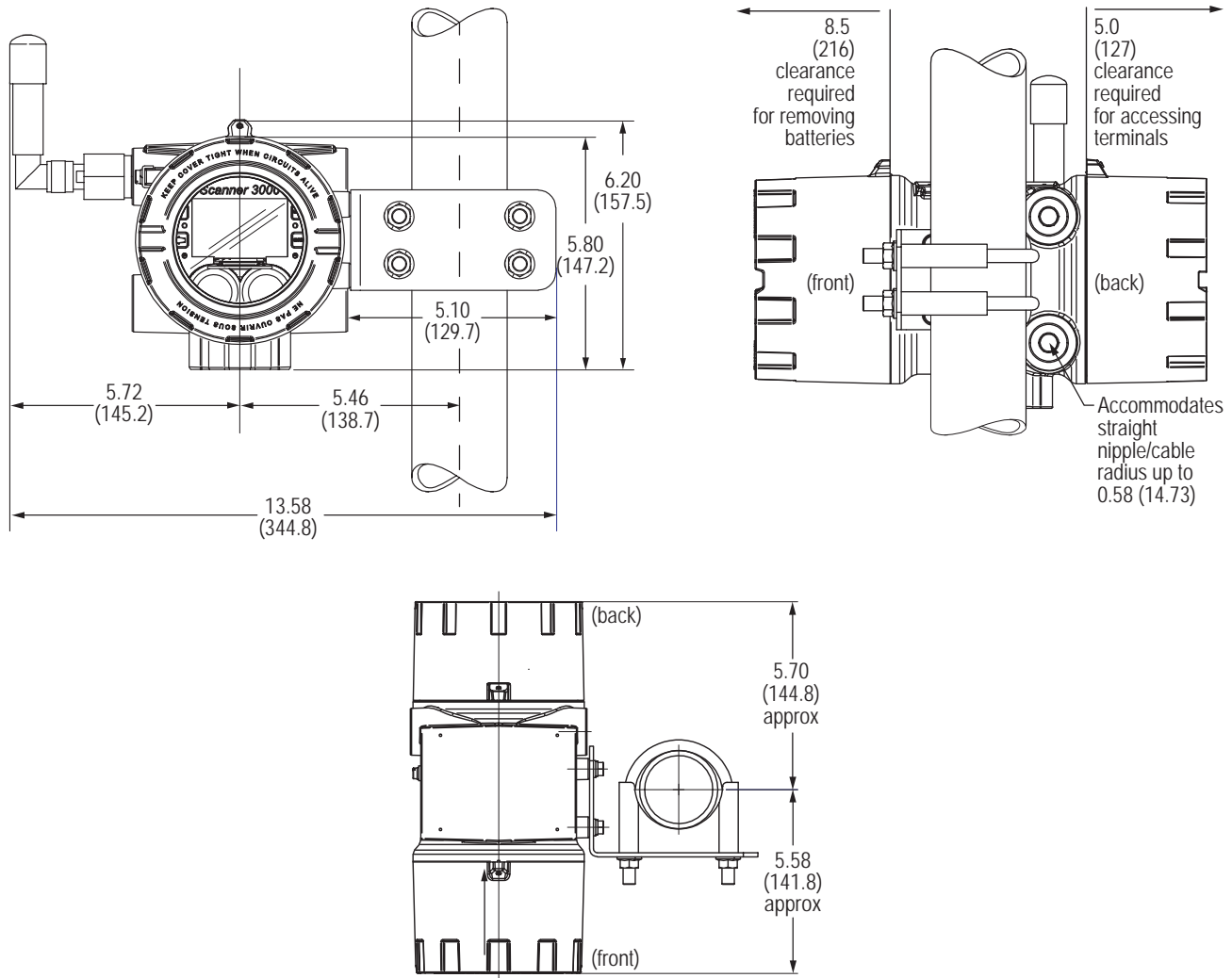

Figure 2.2—QRATE Scanner 3100 remote-mounted with a 2-in. pole mount kit; dimensions are shown in inches (mm)

Install as follows:

1. Locate the mounting bosses on the side of the enclosure.
2. Attach the mounting bracket to the bosses using the four 10-mm screws provided. For best stability, orient the bracket so that the flat surface of the “L” bracket is near the front of the enclosure.
3. Position the device with bracket against the pole so that the bracket is directly in front of the pole.
4. Install the two U-bolts around the pole and through the mounting holes in the bracket.
5. Tighten the U-bolts securely.
6. Install and connect process piping between the device and the flow meter with appropriate fittings. Process piping installation procedures vary with each application.

Hazardous Area Requirements for WiFi and Wireless Communications

The QRATE Scanner 3100 WiFi (with internal or external antenna) and wireless modules connect to their respective antennas inside of the enclosure. A remote antenna and antenna cable are optionally available if obstructions to reliable signal transmissions are present. [Figure 2.3](#) shows installation dimensions for the device equipped with the direct-mount, right-angle antenna supplied by Sensia.

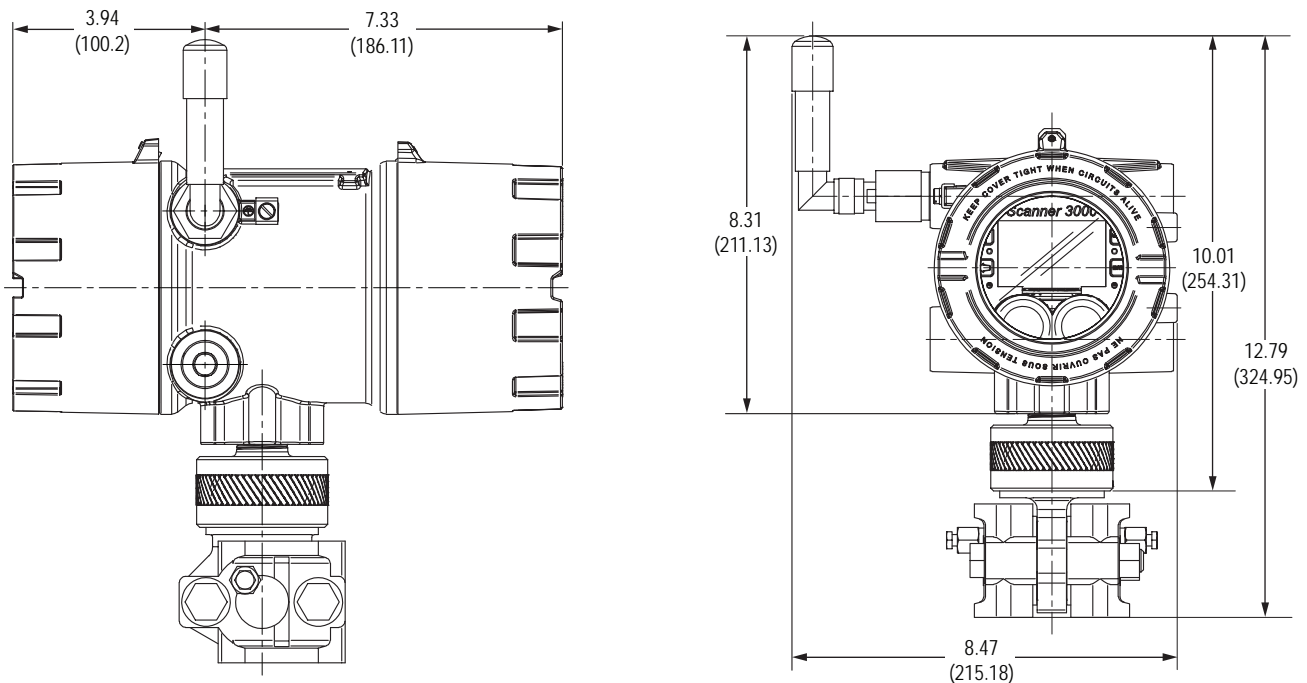

Figure 2.3—Wireless QRATE Scanner 3100 with MVT and direct-mount antenna; dimensions are shown in in. (mm)

The installation of the antenna coupler, antennas, and antenna cable must meet the requirements shown in [Figure 2.4, page 30](#) and [Figure 2.5, page 30](#).

Sensia supplies the following antenna and antenna cable options:

- Direct-mount, right-angle antenna with N male connector (WiFi may use internal or external antenna)
- Remote-mount antenna with N female connector
- Type 400 male-to-male antenna cable in three lengths - 10, 20, and 30 feet

See [Table 7.2—Wireless Components, page 89](#) for ordering details.

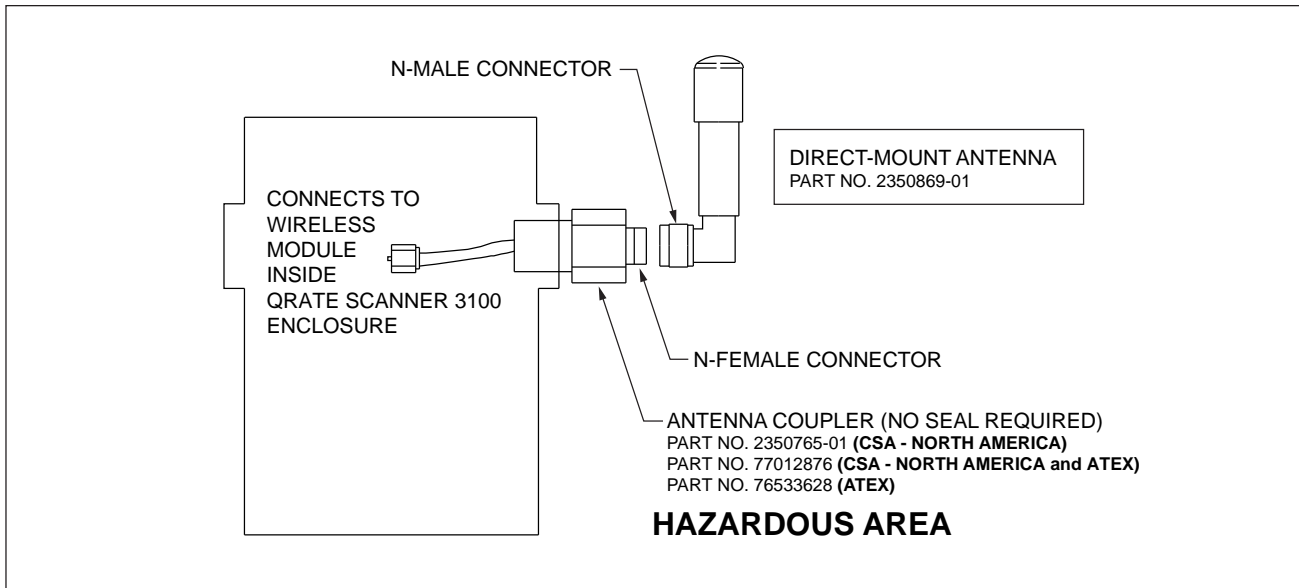

Figure 2.4—Installation requirements for a direct-mount Sensia-supplied antenna

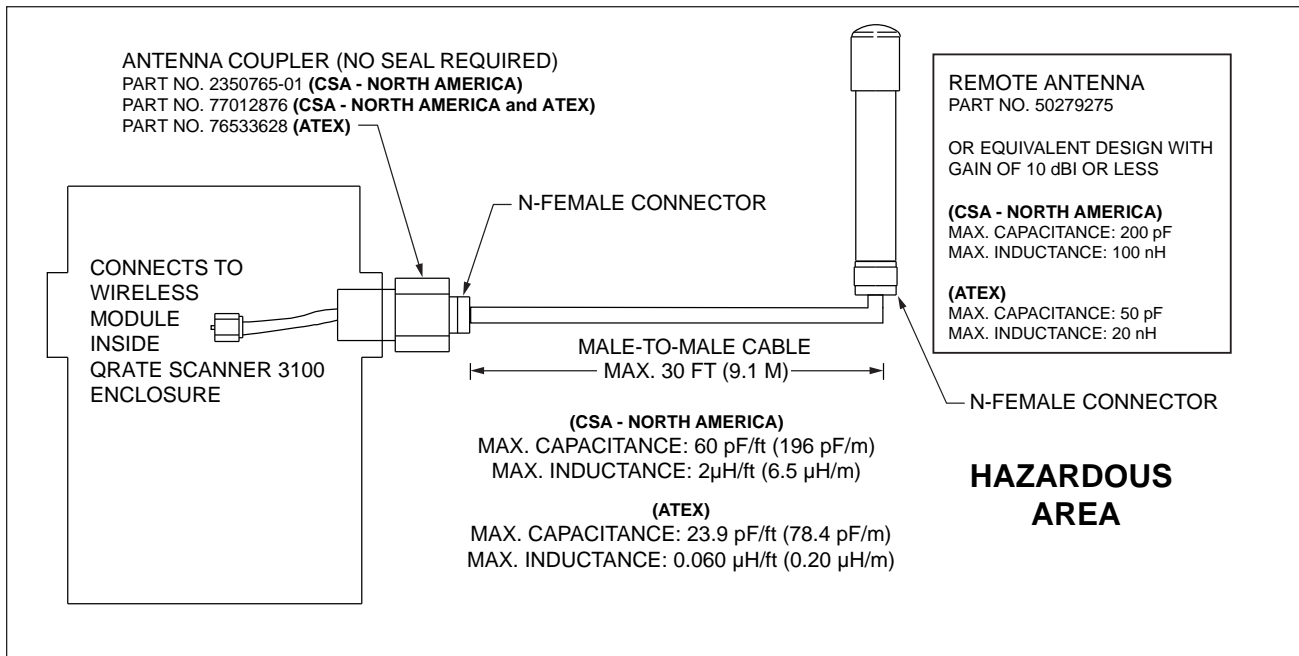

Figure 2.5—Installation requirements for a remote-mount antenna

FCC Radio Frequency Compliance

QRATE Scanner 3100s that include the optional WiFi or SmartMesh radio modules comply with Federal Communications Commission (FCC) radio frequency (RF) exposure compliance requirements when the following requirements are met.

IMPORTANT	To comply with FCC and IC RF exposure compliance requirements, the antenna must be installed to provide a separation distance of at least 20 cm from all persons. Changes or modifications to the installation that violate this requirement and are not authorized by the radio manufacturer could void your authority to operate the equipment.
------------------	---

The SmartMesh radio has been tested and found to comply with the limits for a Class B digital device, pursuant to Part 15 of the FCC Rules. These limits are designed to provide reasonable protection against harmful

interference in a residential installation. This equipment generates, uses and can radiate radio frequency energy and, if not installed and used in accordance with the instructions, may cause harmful interference to radio communications. However, there is no guarantee that interference will not occur in a particular installation. If this equipment does cause harmful interference to radio or television reception, which can be determined by turning the equipment off and on, you are encouraged to try to correct the interference by one or more of the following measures:

- Reorient or relocate the receiving antenna.
- Increase the separation between the equipment and receiver.
- Connect the equipment to an outlet on a circuit different from that used with the receiver.
- Consult the dealer or an experienced radio/TV technician for help.

IC Radio Frequency Compliance

QRATE Scanner 3100s that include the optional WiFi or SmartMesh radio modules comply with Industry Canada (IC) license-exempt RSS standards. Operation is subject to the following conditions:

- The device may not cause interference.
- The device must accept any interference, including interference that may cause undesired operation of the device.

Radio Frequency Compliance Labeling

QRATE Scanner 3100s that include the optional SmartMesh radio module comply with a broad range of country-specific radio frequency standards. The device wireless radio is approved for use in all of the regions listed on a radio compliance label (Figure 2.6) applied to the enclosure.

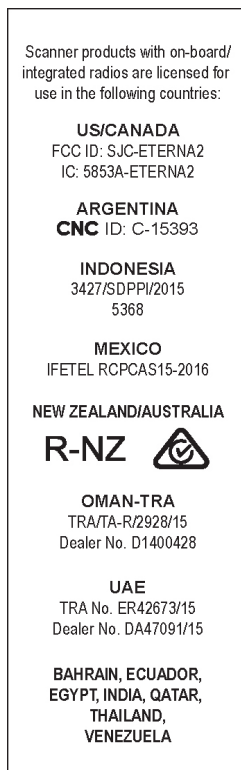

Figure 2.6—Radio frequency compliance label applied to the QRATE Scanner 3100 enclosure (content may change without notice)

Antenna Installation Options

Direct-Mount Antenna

Each QRATE Scanner 3100 wireless device is equipped with a wireless module (installed on an advanced communications circuit board) and an explosion-proof coupler that threads into an enclosure port. Antennas and antenna cable are optionally available (WiFi may use internal or external antenna).

The installation of the antenna coupler, antennas, and antenna cable must meet the requirements shown in [Figure 2.4](#) and [Figure 2.5, page 30](#).

Remote-Mount Antenna for Pole Outside Diameters up to 2 Inches

The standard hardware supplied with Sensia's remote-mount antenna can be used to mount the antenna to a pole with an outside diameter of 2 in. or less. The supplied hardware includes two U-bolts, two toothed brackets, four lock washers and four nuts.

Note	If a 2-in. pipe with a 2 3/8-in. outside diameter is to be used, consider using Sensia's 2-in. pipe mount hardware kit.
------	---

To install the antenna, reference [Figure 2.7](#) while following the instructions below:

1. Position the antenna with the shiny metal base against a vertical pole and the capped end of the antenna vertical in the air. Note the N-female cable connector at the bottom of the metal base for connecting antenna cable.
2. Position a U-bolt around the antenna and pole, placing the bend of the U-bolt against the antenna base.
3. Place a toothed bracket over the threaded legs of the U-bolt with the teeth facing the pole and slide the bracket snugly against the pole.
4. Install a lock washer and a nut on each of the two U-bolt legs extending through the toothed bracket.
5. Repeat steps 2 through 4 to install the second U-bolt and toothed bracket to secure the base of the antenna.
6. Attach the antenna cable to the N-female cable connector at the bottom of the antenna.

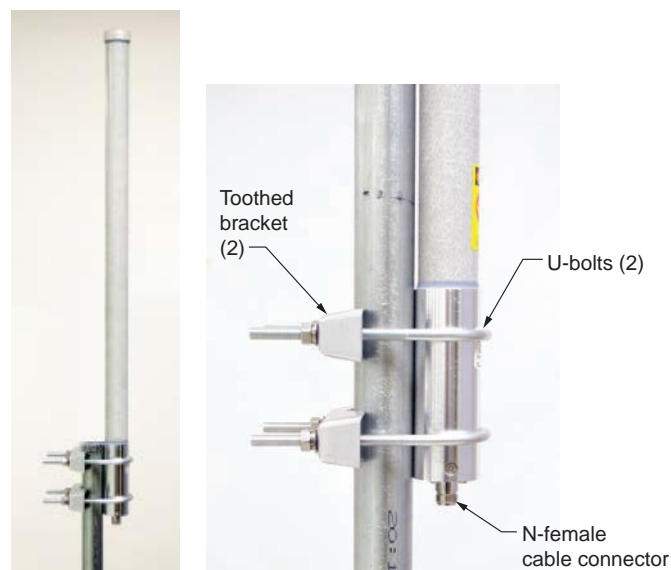

Figure 2.7—Standard pole mount bracket (fits poles with an outside diameter of 2 in. or less)

Remote-Mount Antenna for Pipe Outside Diameters of 2 3/8 Inches

Sensia's optional pipe mount kit accommodates mounting the remote antenna to a 2-in. pipe with a 2 3/8-in. outside diameter. The hardware kit includes a stainless steel L-shaped bracket, two U-bolts, four U-bolt nuts, two stainless steel 5/16-18 bolts (3.25-in. long), two 5/16-in. lock washers, two 5/16-in. flat washers and two 5/16-in. nuts.

IMPORTANT

One of the toothed brackets shipped with the standard pole-mount kit is also required for this installation. Do not discard the standard pole-mount kit antenna packaging before locating the toothed brackets.

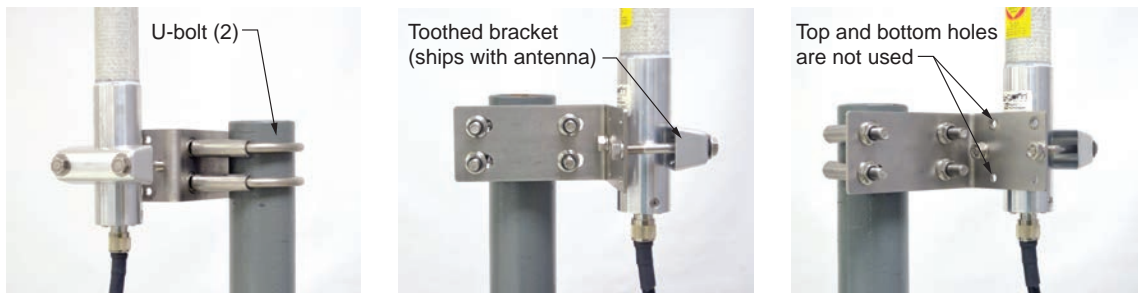

Figure 2.8—Optional 2-in. pipe mount bracket

To install the antenna, reference [Figure 2.8](#) while following the instructions below:

1. Remove one of the toothed brackets from the standard pole-mount kit antenna packaging for use with the optional hardware kit. The remaining hardware in the antenna package will not be used for this installation.
2. Position the L-shaped bracket against the pipe so that the pipe is on the outside of the “L” and secure it to the pipe with the two U-bolts and four U-bolt nuts ([Figure 2.8](#), left). The U-bolts will pass through the widest panel of the “L” bracket.
3. Position the antenna against the bracket so that the shiny metal base is touching the bracket and the capped end of the antenna is vertical in the air. Note the N-female cable connector at the bottom of the metal base for connecting antenna cable.
4. Place the toothed bracket against the adjacent L-bracket panel (shortest of the two panels) so that the toothed, rounded edge faces the L-bracket panel and the holes in the toothed bracket align with the center holes in the L-bracket.
5. Place a flat washer over each of the 5/16-in. bolts and insert the bolts through the holes in the toothed bracket and through the center holes in the L-bracket panel ([Figure 2.8](#), center and right).
6. Attach a lock washer and a nut to each of the bolts on the inside of the L-shaped bracket to hold the toothed bracket loosely in place.
7. Position the antenna between the toothed bracket and the L-shaped bracket so that the rounded edge of the toothed bracket fits snugly against the curvature of the shiny antenna base and the brackets clamp around the approximate center of the antenna base.
8. Holding the antenna in place, tighten the two 5/16-in. nuts on the inside of the L-bracket to secure the antenna ([Figure 2.8](#), right).
9. Attach the antenna cable to the N-female cable connector at the bottom of the antenna.

Industry Standard Compliance

To ensure measurement accuracy, flow runs and turbine meter runs must be installed in accordance with the industry standards listed in [Table 2.2—Industry Standards for Meter Installation](#). For a complete list of industry standards used in the development of flow rate and fluid property calculations, see [Table 1.4—Flow Rate Standards, page 21](#) and [Table 1.5—Fluid Property and Energy Flow Calculations, page 22](#).

Table 2.2—Industry Standards for Meter Installation

<i>Meter Type</i>	<i>Standard</i>	<i>Description</i>
Orifice Meter	AGA 3, <i>Section 2.6</i>	Specifications for orifice meters (to include beta ratios)
		Installation requirements for orifice plates, meter tubes, flow conditioners, and thermometer wells
		This standard is also distributed under the following names: API MPMS Chapter 14.3, Part 2; ANSI/API 14.3, Part 2-3100; and GPA 8185, Part 2.
	ISO 5167, <i>Part 1</i>	Installation of orifice plates inserted into a circular cross-section conduit running full
		Limitation of pipe size and Reynolds number
		ISO 5167 is applicable only to flow that remains subsonic throughout the measuring section and where the fluid can be considered single-phase. It is not applicable to the measurement of pulsating flow. It does not cover the use of orifice plates in pipe sizes less than 50 mm (2 in.) or more than 1000 mm (39 in.), or for pipe Reynolds numbers below 5000.
	ISO 5167, <i>Part 2</i>	Specifies orifice plates that can be used with flange pressure tapplings, corner pressure tapplings, D and D/2 pressure tapplings.
	API MPMS Chapter 21.1, <i>Section 1.7</i>	Installation of electronic gas measurement devices and associated communications, gauge/impulse lines, and cabling
	API MPMS Chapter 21.1, <i>Section 1.8</i>	Requirements for calibrating and verifying the accuracy of electronic gas measurement devices
	ASME MFC-14M	Specifies low-flow orifice meters smaller than 2 inch pipe size, that can be used with flange taps and corner taps.
		Nominal pipe sizes (1/2 inch to 1-1/2 inch only)
		Beta ratio from 0.1 to 0.75
Suitable for single-phase fluids only		
Subsonic flow only		
	Not suitable for pulsating flow	
Cone Meter	NuFlo* <i>Cone Meter User Manual, Sections 2 through 5</i>	System components, impulse tubing considerations, best practices for installation, installation procedures/diagrams for liquid and gas service
	ISO 5167, <i>Part 1</i>	Installation of orifice plates inserted into a circular cross-section conduit running full
		Limitation of pipe size and Reynolds number
		ISO 5167 is applicable only to flow that remains subsonic throughout the measuring section and where the fluid can be considered single-phase. It is not applicable to the measurement of pulsating flow. It does not cover the use of orifice plates in pipe sizes less than 50 mm (2 in.) or more than 1000 mm (39 in.), or for pipe Reynolds numbers below 5000.
ISO 5167, <i>Part 5</i>	ISO 5167-5 describes the background information for calculating the flow rate and is applicable in conjunction with the requirements given in ISO 5167-1. Uncalibrated cone meters can only be used within specified limits of pipe size, roughness, β , and Reynolds number. This part of ISO 5167 is not applicable to the measurement of pulsating flow. It does not cover the use of uncalibrated cone meters in pipes sized less than 50 mm or more than 500 mm, or where the pipe Reynolds numbers are below 8×10^4 or greater than 1.2×10^7 .	

Table 2.2—Industry Standards for Meter Installation

<i>Meter Type</i>	<i>Standard</i>	<i>Description</i>
Venturi Meter	<i>ISO 5167, Part 1</i>	Installation of orifice plates inserted into a circular cross-section conduit running full
		Limitation of pipe size and Reynolds number
		ISO 5167 is applicable only to flow that remains subsonic throughout the measuring section and where the fluid can be considered single-phase. It is not applicable to the measurement of pulsating flow. It does not cover the use of orifice plates in pipe sizes less than 50 mm (2 in.) or more than 1,000 mm (39 in.), or for pipe Reynolds numbers below 5,000.
	<i>ISO 5167, Part 3</i>	ISO 5167-3 describes three Venturi meter variations: machined inlet, rough cast inlet, and welded sheet metal. Machined inlet meters are available in diameters up to 10 inches (250 mm), rough cast meters up to 30 inches (800 mm), and welded construction up to 47 in. (1,200 mm).
Turbine Meter/ Volumetric Pulse Meter	<i>AGA 7, Section 7</i>	Installation of gas turbine meters to include flow direction, meter orientation, meter run connections, internal surfaces, temperature well location, pressure tap location, and flow conditioning
		Illustrations of recommended installation configurations
		Environmental considerations, the use of other devices to improve meter performance, and precautionary measures
		This specification applies to axial-flow turbine flow meters for measurement of natural gas, typically 2-in. and larger bore diameter, in which the entire gas stream flows through the meter rotor.
	<i>API MPMS Chapter 21.1, Section 1.7</i>	Installation of electronic gas measurement devices and associated communications, gauge/impulse lines, and cabling
	<i>API MPMS Chapter 21.1, Section 1.8</i>	Requirements for calibrating and verifying the accuracy of electronic gas measurement devices
	<i>API MPMS 5, Section 3</i>	Description of unique installation requirements and performance characteristics of turbine meters in liquid hydrocarbon service (<i>This section does not apply to the measurement of two-phase fluids.</i>)
	<i>ISO 5167, Part 1</i>	Installation of orifice plates inserted into a circular cross-section conduit running full
		Limitation of pipe size and Reynolds number
		ISO 5167 is applicable only to flow that remains subsonic throughout the measuring section and where the fluid can be considered single-phase. It is not applicable to the measurement of pulsating flow. It does not cover the use of orifice plates in pipe sizes less than 50 mm (2 in.) or more than 1,000 mm (39 in.), or for pipe Reynolds numbers below 5,000.
Coriolis Meter /Mass Pulse Meter	<i>AGA 11</i>	AGA 11 was developed for the specification, calibration, installation, operation, maintenance and verification of Coriolis flow meters and is limited to the measurement of single phase natural gas, consisting primarily of hydrocarbon gases mixed with other associated gases usually known as “diluent”.

Measuring Natural Gas via a Differential Pressure Meter

Best Practices

For best measurement accuracy, ensure that the meter run complies with the following AGA 3 and ISO 5167 guidelines, as applicable:

- Do not place unit near vents or bleed holes that discharge corrosive vapors or gases.
- Consider the orientation of the meter run when determining the best position for mounting the QRATE Scanner 3100.
 - If the device is mounted to a horizontal pipeline, make sure process connections are at the top of the line, and mount the device above the pressure connections at the pipe.
 - If the device is mounted to a vertical pipeline, install the sensor above the differential pressure source connections, or install a condensate (drip) pot to prevent the accumulation of liquid in interconnecting tubes. Slope all tubing upward at least 1 in./LF to avoid liquid entrapment.
- Mount the QRATE Scanner 3100 as near level as possible such that the operator has a clear view of the LCD and can access the keypad easily when the enclosure cover is removed. The location should be as free from vibration as possible.
- Ensure the high port of the sensor (marked H) is connected to the upstream side of the meter run.
- Flow should remain subsonic throughout the measuring section and should be single phase.
- Pipe diameters (D) should be between 2 in. (50 mm) and 39 in. (1,000 mm) per ISO 5167; or greater than 2 in. (50 mm) per AGA 3.
- Pipe Reynolds numbers must be above 5,000.
- d (orifice diameter) must be greater than or equal to 0.45 in. (11.5 mm).
- β (diameter ratio) must be greater than or equal to 0.1 and less than or equal to 0.75.
- Gauge lines should be of uniform internal diameter and constructed of material compatible with the fluid being measured. For most applications, the bore should be no smaller than 1/4 in. (6 mm) and preferably, 3/8 in. (10 mm) in diameter. The internal diameter should not exceed 1 in. (25 mm). If high-temperature fluids are likely to be encountered, make sure the measuring tube used is rated for the anticipated temperature range.
- Gauge line length should be minimized to help prevent pulsation-induced errors.
- Gauge lines should slope downward to the meter at a minimum of 1 in. per foot.
- If gauge lines must slope in more than one direction, do not allow more than one bend and install a liquid or gas trap, as applicable. A liquid trap should be installed at the lowest point in a gas service installation.
- Gauge lines should be supported to prevent sag and vibration.
- Where pulsation is anticipated, full-port manifold valves with a nominal internal diameter consistent with the gauge lines are recommended.

If the QRATE Scanner 3100 is mounted to a cone meter, consider the following best practices as well:

- Position the cone meter so that there are 0 to 5 diameters of straight pipe upstream of the meter and 0 to 3 diameters of straight pipe downstream of the meter.
- Install the meter so that the static pressure tap is upstream of the differential pressure tap. The high side of the device's integral sensor must also be situated upstream.
- Install shutoff valves directly on the pressure taps. Choose a shutoff valve that is rated for the ambient temperatures of the location and the operating pressure of the pipe in which it will be installed, and suitable for use with dangerous or corrosive fluids or gases, if applicable. The valves must not affect the transmission of the differential pressure signal.

Direct Mount to Orifice Meter or Cone Meter

A QRATE Scanner 3100 can be mounted directly to an orifice meter or cone meter for gas measurement. The setup of the meter run and plumbing configurations can vary widely, depending upon the challenges existing on location. [Figure 2.9](#) shows a typical direct-mount installation.

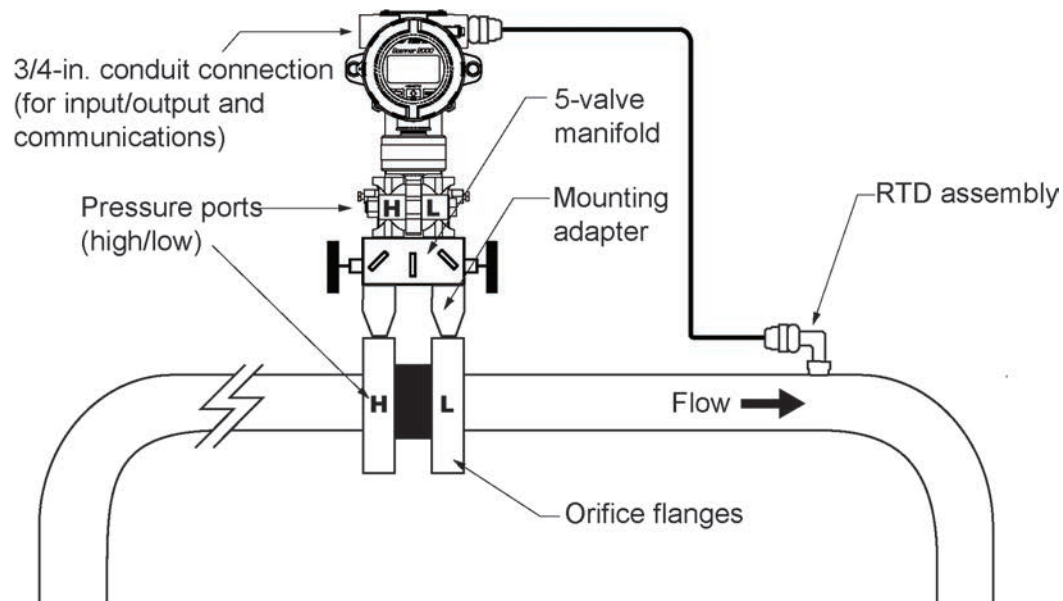

Figure 2.9—Direct-mount installation in an orifice meter run. The direct-mount method can be used with a cone meter as well.



WARNING

HAZARDOUS AREA USE. The QRATE Scanner 3100 is certified for hazardous area use only when installed in accordance with applicable standards and local wiring practices. Carefully review [Hazardous Area Precautions, page 25](#) to determine specific installation requirements (cable glands, conduit seals, signal cable, RTD, etc.).

1. Verify that the meter is properly installed in the flow line (per manufacturer's instructions).
2. Bolt a flange-by-flange 5-valve manifold (as recommended by Sensia) to the device's MVT sensor.
 - a. Locate the H and L markings on the MVT sensor body and position the MVT/manifold assembly so that the upstream side of the flow line can easily be connected to the sensor's "High" port and the downstream side of the flow line can be connected to the sensor's "Low" port. The enclosure can be rotated to face the desired direction.
 - b. Position the manifold so that all valves are accessible from the front of the instrument.
3. Connect the QRATE Scanner 3100 and manifold assembly to the differential pressure meter. Hardware requirements will vary, depending upon the installation configuration. Minimally, an adapter that can span between the threaded pressure tap/orifice flange connector and the non-threaded manifold is required. This adapter can be a one-piece stabilizer (often preferred for added strength and stability) or a short heavy-wall pipe nipple attached to a football flange (available from Sensia). Use a suitable compound or tape on all threaded process connections.

CAUTION

Do not use Teflon tape on the threads of the union, adapter, or pipe plugs that may be installed in the enclosure. Use of Teflon tape will void the explosion-proof rating of the instrument.

4. Install the RTD assembly in the thermowell. Route the RTD assembly cable through a conduit opening in the top of the enclosure to connect to the terminal board. A wiring diagram for the RTD assembly is provided in [Figure 3.6, page 59](#). For hazardous areas, review [Hazardous Area Precautions, page 25](#).

5. Route any additional inputs/outputs or COM connections, etc. through a conduit opening in the top of the enclosure. For hazardous areas, review [Hazardous Area Precautions, page 25](#).
6. Perform a manifold leak test as described in [Performing a Manifold Leak Test, page 50](#).
7. Verify the zero offset, if required (and other calibration points, if desired). See the QRATE Scanner 3100 Web Interface User Manual for complete instructions. See also [Zero Offset \(Static Pressure or Differential Pressure\), page 50](#), [Differential Pressure Calibration and Verification, page 52](#), and [Static Pressure Calibration and Verification, page 51](#).

CAUTION

Do not put the Scanner into operation until the valves are positioned properly so that pressure is supplied to both sides of the MVT. For instructions on proper valve positions, see [Placing the Scanner into Operation, page 53](#).

Remote Mount to Orifice Meter or Cone Meter

A QRATE Scanner 3100 can be mounted remotely and connected to an orifice meter or cone meter with tubing for gas measurement. The setup of the meter run and plumbing configurations can vary widely, depending upon the challenges existing on location. [Figure 2.10, page 39](#) shows a typical remote-mount gas run installation.

**WARNING**

HAZARDOUS AREA USE. The QRATE Scanner 3100 is certified for hazardous area use only when installed in accordance with applicable standards and local wiring practices. Carefully review [Hazardous Area Precautions, page 25](#) to determine specific installation requirements (cable glands, conduit seals, signal cable, RTD, etc.).

Note

To prevent fittings from turning and to avoid putting tension on stainless steel tubing, use a backup wrench to attach stainless steel tubing to a manifold, shutoff valves, or sensor ports.

1. Verify that the meter is properly installed in the flow line (per manufacturer's instructions).
2. Mount the device to a 2-in. pipe using the mounting bosses on the side of the enclosure and a Sensia pole mount kit. See [Pole-Mounting the QRATE Scanner 3100, page 28](#) for detailed mounting instructions.
3. Bolt a 5-valve flange-by-NPT manifold (as recommended by Sensia) to the device's MVT sensor.
 - a. Locate the H and L markings on the integral MVT sensor body and position the MVT/manifold assembly so that the upstream side of the flow line can easily be connected to the sensor's "High" port and the downstream side of the flow line can be connected to the sensor's "Low" port. The enclosure can be rotated to face the desired direction.
 - b. Position the manifold so that all valves are accessible from the front of the instrument.
4. Install tubing and fittings to connect the device and manifold assembly to the differential pressure meter, sloping the gauge lines downward to the meter at a minimum of one inch per foot. Use a suitable compound or tape on all threaded process connections.

CAUTION

Do not use Teflon tape on the threads of the union, adapter, or pipe plugs that may be installed in the enclosure. Use of Teflon tape will void the explosion-proof rating of the instrument.

5. Install the RTD assembly in the thermowell. Route the RTD assembly cable through a conduit opening in the top of the enclosure to connect to the terminal board. A wiring diagram for the RTD assembly is provided in [Figure 3.6, page 59](#). For hazardous areas, review [Hazardous Area Precautions, page 25](#).
6. Route any additional inputs/outputs or COM connections, etc. through a conduit opening in the top of the enclosure. For hazardous areas, review [Hazardous Area Precautions, page 25](#).
7. Perform a manifold leak test as described in [Performing a Manifold Leak Test, page 50](#).

8. Verify the zero offset (if required) and other calibration points (if desired). See the QRATE Scanner 3100 Web Interface User Manual for complete instructions. See also [Zero Offset \(Static Pressure or Differential Pressure\)](#), page 50, [Differential Pressure Calibration and Verification](#), page 52, and [Static Pressure Calibration and Verification](#), page 51.

CAUTION

Do not put the Scanner into operation until the valves are positioned properly so that pressure is supplied to both sides of the MVT. For instructions on proper valve positions, see [Placing the Scanner into Operation](#), page 53.

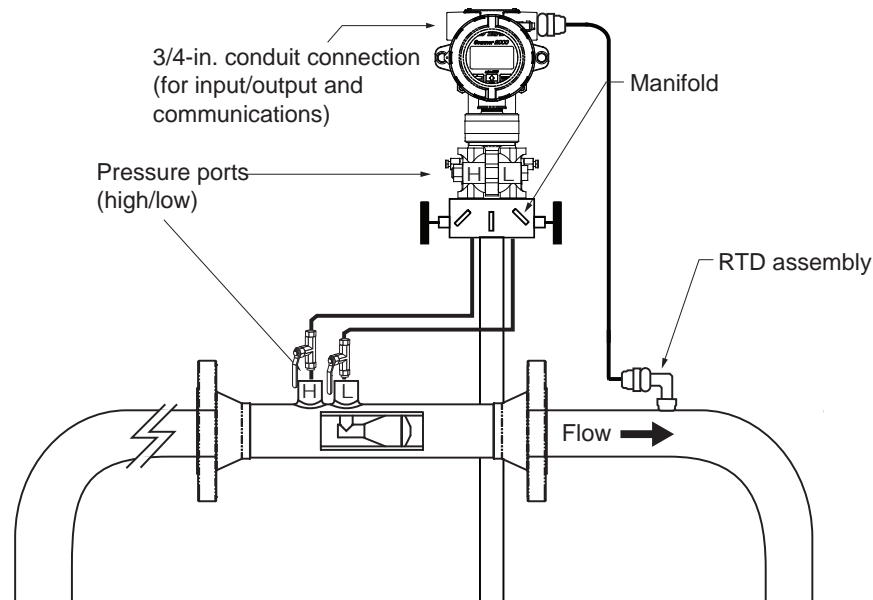

Figure 2.10—Remote-mount gas cone meter run installation. The remote-mount method can be used with an orifice meter as well.

Measuring Natural Gas via a Turbine Meter

Best Practices

The QRATE Scanner 3100 calculates gas flow through a turbine meter in accordance with AGA 7 and API MPMS Chapter 21.1 industry standards. For optimum performance, ensure that the turbine and device installation complies with the industry recommendations listed below:

- Install the turbine flowmeter in the meter run such that there are 10 nominal diameters of straight pipe upstream and 5 nominal diameters of straight pipe downstream of the meter. Both inlet and outlet pipe should be of the same nominal size as the meter.
- Straightening vanes are recommended for eliminating swirl conditions. If used, they should be installed 5 diameters of straight pipe upstream of the meter.
- Where an RTD is used to facilitate compensated gas measurement from a gas turbine meter, locate the RTD within 5 diameters of straight pipe downstream of the meter outlet and upstream of any valve or flow restriction.

Remote Mount to a Turbine Meter

A QRATE Scanner 3100 can be mounted remotely and connected to a gas turbine meter for measuring gas in accordance with AGA 7 calculations. [Figure 2.11, page 41](#) shows an installation in which the pressure input is provided by the integral MVT. The setup of the meter run and plumbing configurations can vary widely, depending upon the challenges existing on location.



WARNING

HAZARDOUS AREA USE. The QRATE Scanner 3100 is certified for hazardous area use only when installed in accordance with applicable standards and local wiring practices. Carefully review [Hazardous Area Precautions, page 25](#) to determine specific installation requirements (cable glands, conduit seals, signal cable, RTD, etc.).

To connect the QRATE Scanner 3100 to a turbine meter, perform the following steps:

1. Verify that the flowmeter and magnetic pickup are installed in the flow line.
2. Mount the device to a 2-in. pipe using the mounting bosses on the side of the enclosure and a Sensia pole mount kit. See [Pole-Mounting the QRATE Scanner 3100, page 28](#) for detailed mounting instructions.
3. Bolt a 3-valve flange-by-NPT manifold (as recommended by Sensia) to the device's MVT sensor. Position the manifold so that all valves are accessible from the front of the instrument.
4. Connect the pressure port of the turbine meter to either manifold process port with tubing. The unused pressure port can be used as a "vent" as required. Always leave the equalizer valves open to allow pressure to both sides of the MVT. Use a suitable compound or tape on all threaded process connections.

CAUTION

Do not use Teflon tape on the threads of the union, adapter, or pipe plugs that may be installed in the enclosure. Use of Teflon tape will void the explosion-proof rating of the instrument.

5. Remove the plug from the conduit opening in the top of the enclosure, route the turbine signal cable through the opening, and connect it to the terminal board. A wiring diagram for the turbine input is provided in [Figure 3.7, page 60](#). For hazardous areas, review [Hazardous Area Precautions, page 25](#).
6. Install the RTD assembly in the thermowell. Remove the plug from the other conduit opening in the top of the enclosure, route the RTD assembly cable through the conduit opening in the top of the enclosure, and connect it to the terminal board. A wiring diagram for the RTD assembly is provided in [Figure 3.6, page 59](#). For hazardous areas, review [Hazardous Area Precautions, page 25](#).
7. Zero the static pressure and recalibrate, if required. See the QRATE Scanner 3100 Web Interface User Manual for complete instructions. See also [Zero Offset \(Static Pressure or Differential Pressure\), page 50](#), [Differential Pressure Calibration and Verification, page 52](#), and [Static Pressure Calibration and Verification, page 51](#).

CAUTION

Do not put the Scanner into operation until the valves are positioned properly so that pressure is supplied to both sides of the MVT. For instructions on proper valve positions, see [Placing the Scanner into Operation, page 53](#).

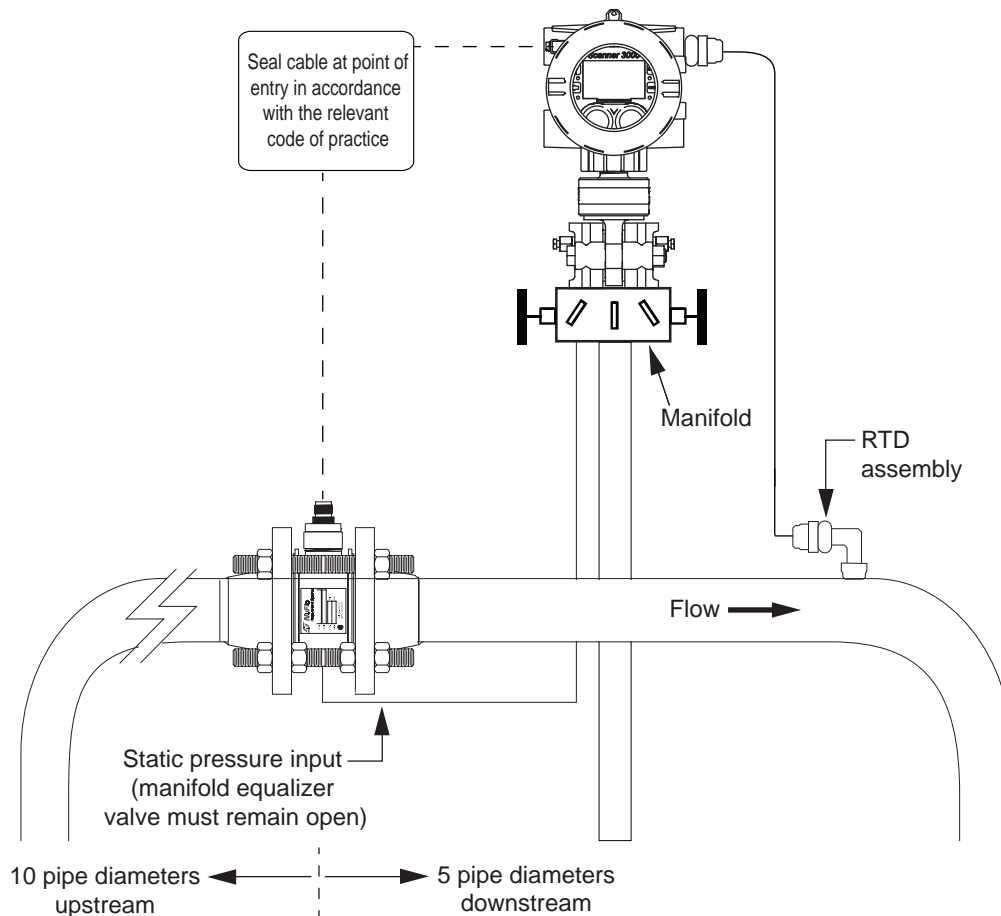

Figure 2.11—Remote-mount installation in an AGA 7 turbine meter run

Measuring Steam via a Differential Pressure Meter

Note	Steam fluid types are only supported for flow rate calculation methods using orifice meters or cone meters.
------	---

Best Practices

The QRATE Scanner 3100 calculates steam flow in accordance with IF-97, AGA-3, and ISO-5167 industry standards. For optimum performance, ensure that the installation complies with the following industry recommendations:

Condensate Pots

- A condensate pot for a small-volume transducer like the device's MVT can be a simple pipe tee, oriented so that one port extends downward (into the cold leg), the opposite port extends upward and is closed by a pipe cap or blowdown valve, and the tee extends horizontally into the hot leg.
- The pots should be the highest point in the system.
- The pots should be mounted at the same level, and one or both should be adjustable vertically to remove zero shifts in the differential pressure measurement.

Hot Legs

- Hot legs should be large diameter (1/2 in. recommended)
- Hot legs should be as short as possible. If these sections must be more than 1ft in length, insulate them.
- Elbows and bends should not form any traps in which liquid can accumulate.
- Hot legs should be sloped along their entire length to allow liquids to drain back into the pipe.

Cold Legs

- Cold legs should enter the multi-variable sensor through its bottom ports. Side port installation is also available. Contact your sales representative or technical support for assistance with side port installation.
- Cold legs should not be insulated and should be a minimum of 2 ft in length to allow proper convection cooling of the process fluid to below 120 °F. The nominal rate of cooling is 100 °F/ft, with an ambient temperature of 70 °F.
- If the cold leg must be installed horizontally, ensure a slope of approximately 1 in./ft to allow air bubbles to float up into the pots.
- Elbows and bends should not form any traps for air bubbles.
- Cold legs should be filled with a suitable antifreeze. Dibutyl phthalate is recommended.

Antifreeze

Dibutyl phthalate (DBP) has the following advantages over glycol antifreeze:

- Does not mix with water, and therefore does not become dilute over time; its specific gravity does not shift.
- It is slightly denser than water, so it will stay in the pot permanently.
- It is non-flammable.
- It is much less toxic than glycol.
- It is available from industrial suppliers.

Valves

- Use only full-opening block valves that are rated for steam service.
- Use only blowdown valves rated for steam service. Periodic blowdowns are recommended to prevent scale build up.

CAUTION

Before starting the system, remove the caps and add water or antifreeze if necessary to completely fill the pots and cold legs. Air trapped in the lines will produce errors in differential pressure measurements.



WARNING

EXPLOSION RISK. Housing temperature must not exceed 70 °C (158 °F). Excessive temperatures, which could result from ambient conditions combined with radiated and conductive heat from the process, could cause the internal lithium battery to ignite or explode.

Installation Procedure—Remote Mount to Orifice Meter or Cone Meter

A QRATE Scanner 3100 can be mounted remotely and connected to an orifice meter or cone meter with tubing for steam measurement. The setup of the meter run and plumbing configurations can vary widely, depending upon the challenges existing on location.

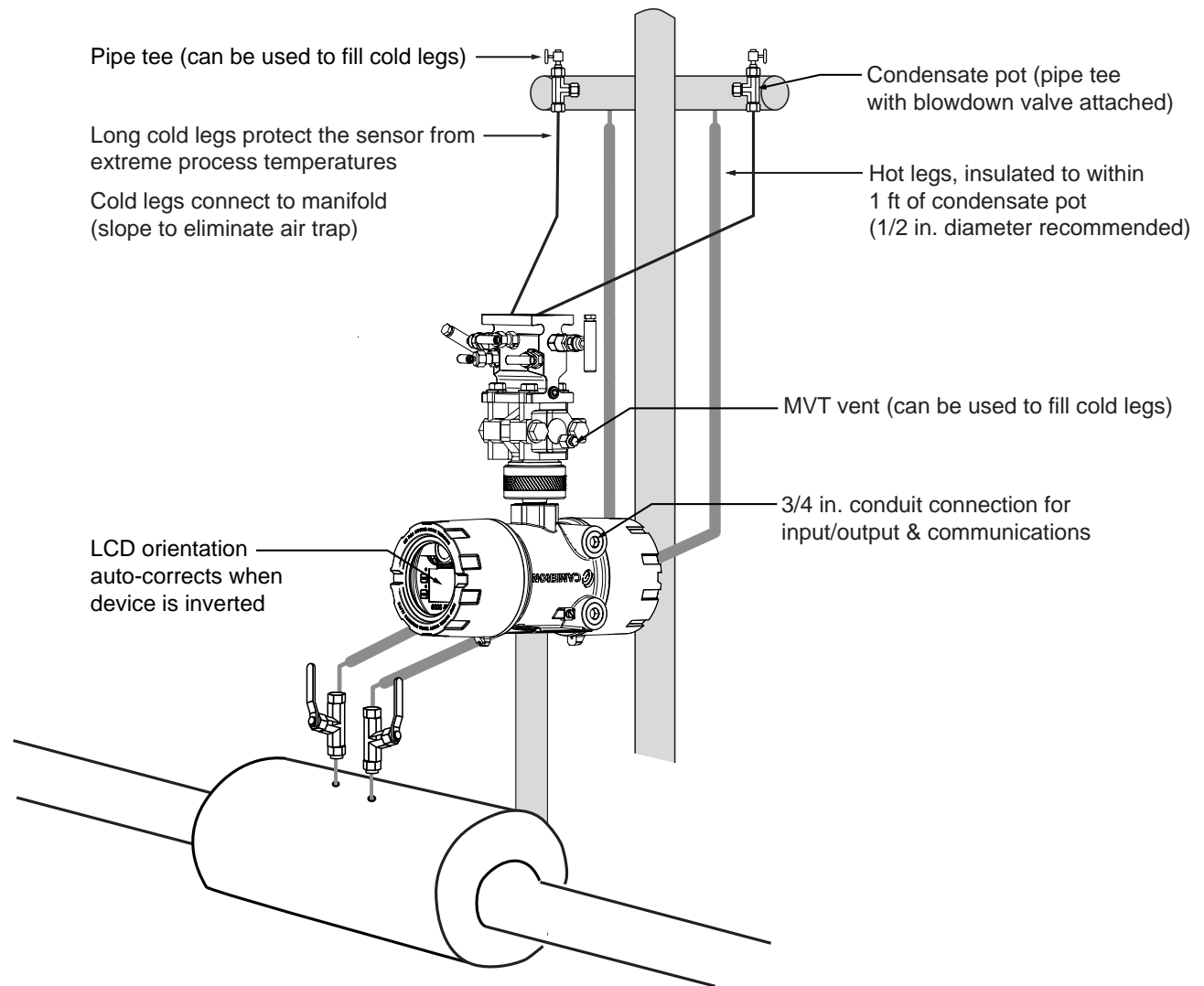

Figure 2.12—Remote-mount steam run installation



WARNING

HAZARDOUS AREA USE. The QRATE Scanner 3100 is certified for hazardous area use only when installed in accordance with applicable standards and local wiring practices. Carefully review [Hazardous Area Precautions, page 25](#) to determine specific installation requirements (cable glands, conduit seals, signal cable, RTD, etc.).

IMPORTANT

When measuring steam, process connections must be designed to eliminate air pockets. This is achieved by making sure all tubing in the cold legs slopes upward. A bottom-port MVT and block manifold (shown in [Figure 2.12](#)) is recommended to help prevent air bubbles from being trapped in the sensor.

1. Verify that the meter is properly installed in the flow line (per manufacturer's instructions).
2. Mount the device to a 2-in. pipe or to a flat, vertical surface using bolts and the mounting holes in the enclosure. A horizontal pipe is recommended, as additional hardware may be required for a vertical pipe mount to provide clearance for the manifold block.
3. Mount a set of pipe tees (which serve as condensate pots) typically on either side of the enclosure at an elevation above the process connections of the device's MVT (for proper drainage). They should be a considerable distance (see [Best Practices, page 41](#)) from the sensor ports, but as close as possible to the pressure taps on the meter.

4. Install a pipe cap or a blowdown valve that is rated for steam service at the top of each pipe tee. A blowdown valve is recommended when the steam passing through the meter is known to be dirty.
5. Install tubing and fittings to connect the high-pressure and low-pressure taps of the DP meter to the pipe tees. This section is typically referred to as the hot legs of the installation, as this section of tubing encounters steam at its highest temperature. Install a shut-off valve near the high and low ports of the DP meter. Use a suitable compound or tape on all threaded process connections.
6. Route any additional inputs/outputs or COM connections, etc. through the conduit opening in the side of the enclosure. For hazardous areas, review [Hazardous Area Precautions, page 25](#).

Note	To prevent fittings from turning and/or to avoid putting tension on stainless steel tubing, use a backup wrench to attach stainless steel tubing to shut-off valves or sensor ports.
------	--

CAUTION	Whenever possible, locate the hot legs of a steam installation behind the QRATE Scanner 3100 safely out of the operator's normal reach. This will help prevent accidental burns.
---------	--

7. Install tubing to connect the high-pressure and low-pressure process connections of the block manifold to the pipe tees installed in step 3. This tubing section is typically referred to as the cold legs of the installation, since it is filled with water.
8. To eliminate air bubbles, fill the cold legs with water or other fill fluid from the lowest point in the system, typically the MVT, using the following steps:
 - a. Open the blowdown valve or remove the filling plug from one of the pipe tees/condensate pots.
 - b. Open the equalizer and bypass/block valves on the block manifold. Ensure the vent valve is closed.
 - c. Remove the corresponding (high pressure or low pressure) vent screw from the side of the MVT and insert a fitting to allow connection of a hand pump or funnel. If a funnel is used, attach a length of Tygon tubing that is long enough to elevate the funnel well above the condensate pot to force the fluid up the legs.
 - d. Connect a hand pump or funnel to the fitting.
 - e. Pour fill liquid into the funnel or pump it into the cold leg, tapping the cold leg occasionally to dislodge any bubbles.
 - f. Observe the pipe tee/condensate pot and stop pouring when the fill liquid is visible at the top and no air bubbles can be seen.
 - g. Remove the fitting from the vent of the MVT and quickly replace the vent screw and tighten.
 - h. Close the blowdown valve or replace the filling plug from one of the pipe tees/condensate pots.
 - i. Repeat steps a through h for the other cold leg.
9. To eliminate an offset of the differential pressure reading, open the equalizer valves on the block manifold, remove the caps from the seal pots, and adjust either seal pot vertically to bring the water levels to the exact same elevation.
10. Perform a manifold leak test as described on [page 50](#).
11. Verify the zero offset, if required (and other calibration points, if desired). See the QRATE Scanner 3100 Web Interface User Manual for complete instructions. See also [Zero Offset \(Static Pressure or Differential Pressure\), page 50](#), [Static Pressure Calibration and Verification, page 51](#), and [Differential Pressure Calibration and Verification, page 52](#).

CAUTION	Do not put the Scanner into operation until the valves are positioned properly so that pressure is supplied to both sides of the MVT. For instructions on proper valve positions, see Placing the Scanner into Operation, page 53 .
---------	---

Measuring Liquid via a Differential Pressure Meter

Best Practices

To ensure measurement accuracy, ensure that the meter run complies with the following AGA 3 and ISO 5167 guidelines, as applicable:

- Do not place unit near vents or bleed holes that discharge corrosive vapors or gases.
- Consider the orientation of the meter run when determining the best position for mounting the Scanner.
 - If the device is mounted to a horizontal pipeline, make sure process connections are horizontal with the pipeline, or sloped downwards towards the Scanner. Mount the device below the pressure taps at the pipe. Use the side (upper) ports as process connections and the bottom ports for draining and filling the differential pressure housings.
 - If the device is mounted to a vertical pipeline, install the sensor below the differential pressure source connections. Slope all tubing downward at least 1 in./LF to avoid gas entrapment.
- Mount the device as near level as possible such that the operator has a clear view of the LCD, and can access the keypad easily when the enclosure cover is removed. The location should be as free from vibration as possible.
- Make sure the high port of the sensor (marked “H”) is connected to the upstream side of the meter run.
- Pipe diameters (D) should be between 2 in. (50 mm) and 39 in. (1000 mm) per ISO 5167; or greater than 2 in. (50 mm) per AGA 3.
- Pipe Reynolds numbers must be above 5000. Avoid high-viscosity liquids (greater than 15 cP).
- d (orifice diameter) must be greater than or equal to 0.45 in. (11.5 mm).
- Orifice β (diameter ratio) must be greater than or equal to 0.1 and less than or equal to 0.75.
- Gauge lines should be of uniform internal diameter and constructed of material compatible with the fluid being measured. For most applications, the bore should be no smaller than 1/4 in. (6 mm) and preferably, 3/8 in. (10 mm) in diameter. The internal diameter should not exceed 1 in. (25 mm). If high-temperature fluids are likely to be encountered, make sure the measuring tube used is rated for the anticipated temperature range.
- If there is possibility of freezing, the gauge lines can be filled with a suitable seal liquid. The seal liquid should be somewhat denser than the process fluid, should not dissolve in it, should have a sufficiently low freezing point, and should be non-toxic. Alternatively, heat tracing can be used.
- Gauge line length should be minimized to help prevent pulsation-induced errors.
- Gauge lines should slope upward to the meter at a minimum of 1 in./ft.
- If gauge lines must slope in more than one direction, do not allow more than one bend and install a gas trap.
- Gauge lines should be supported to prevent sag and vibration.
- Where pulsation is anticipated, full-port manifold valves with a nominal internal diameter consistent with the gauge lines are recommended.

If the device is mounted to a cone meter, consider the following guidelines in addition to the best practices listed above.

- Position the cone meter so that there are 0 to 5 diameters of straight pipe upstream of the meter and 0 to 3 diameters of straight pipe downstream of the meter.
- Install the meter so that the static pressure tap is upstream of the differential pressure tap. The high side of the device’s integral sensor must also be situated upstream.

- Install shutoff valves directly on the pressure taps. Choose a shutoff valve that is rated for the ambient temperatures of the location and the operating pressure of the pipe in which it will be installed, and for use with dangerous or corrosive fluids or gases, if applicable. The valves must not affect the transmission of the differential pressure signal.

Direct Mount to Orifice Meter or Cone Meter

A QRATE Scanner 3100 can be mounted directly to an orifice meter or cone meter for liquid measurement using a side-port MVT, a block manifold and two football flange adapters ([Figure 2.13, page 47](#)). The setup of the meter run and plumbing configurations can vary widely, depending upon the challenges existing on location.

CAUTION

When measuring liquid with a direct-mount QRATE Scanner 3100, process connections must be parallel to the horizontal center line of the meter, or below the center line to eliminate air pockets.

1. Verify that the meter is properly installed in the flow line (per manufacturer's instructions).
2. Screw a football flange adapter onto each meter pressure tap using pipe tape or pipe dope to seal the threads.
3. Align the bolt holes in the device's MVT and manifold, and install bolts to mate these components to the football flanges, using O-rings as appropriate. Torque the bolts to the manufacturer's specification.
4. Route any additional inputs/outputs, communications connections, etc. through a conduit opening in the top of the enclosure. For hazardous areas, review [Hazardous Area Precautions, page 25](#).
5. Verify that all manifold valves are closed and fill the meter with process fluid.
6. Loosen one of the vent screws in the side of the MVT.
7. Open the equalizer valves and the vent valve on the manifold.
8. Slowly open one of the bypass/block valves on the manifold. Process fluid should immediately spurt from the MVT vent.
9. When air bubbles are no longer visible around the MVT vent, tighten the MVT vent screw.
10. Loosen the other vent screw in the side of the MVT, and repeat steps 7 through 9.
11. Perform a manifold leak test as described in [Performing a Manifold Leak Test, page 50](#).
12. Verify the zero offset (if required) and other calibration points (if desired). See the QRATE Scanner 3100 Web Interface User Manual for complete instructions. See also [Zero Offset \(Static Pressure or Differential Pressure\), page 50](#), [Differential Pressure Calibration and Verification, page 52](#), and [Static Pressure Calibration and Verification, page 51](#).

CAUTION

Do not put the Scanner into operation until the valves are positioned properly so that pressure is supplied to both sides of the MVT. For instructions on proper valve positions, see [Placing the Scanner into Operation, page 53](#).

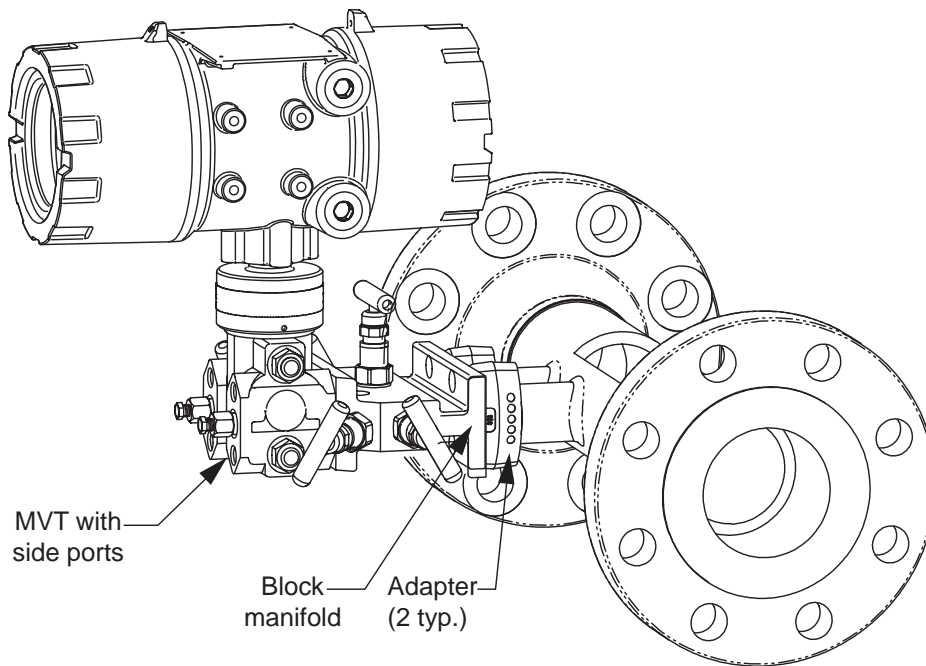

Figure 2.13—Direct-mount liquid cone meter run installation. The downstream RTD is not shown.

Remote Mount to Orifice Meter or Cone Meter

A QRATE Scanner 3100 can be mounted remotely and connected to an orifice meter or cone meter with tubing for liquid measurement (Figure 2.14, page 48). The setup of the meter run and plumbing configurations can vary widely, depending upon the challenges existing on location.



WARNING

HAZARDOUS AREA USE. The QRATE Scanner 3100 is certified for hazardous area use only when installed in accordance with applicable standards and local wiring practices. Carefully review [Hazardous Area Precautions, page 25](#) to determine specific installation requirements (cable glands, conduit seals, signal cable, RTD, etc.).

CAUTION

When measuring liquid, process connections must be designed to eliminate air pockets. This is achieved by mounting the sensor below the metering device and sloping all tubing downward from the meter to the sensor. A side-port MVT and block manifold (shown in [Figure 2.14, page 48](#)) is recommended to help prevent air bubbles from being trapped in the sensor.

If a bottom-port MVT is used, the bottom process ports must be plugged or replaced with a drain valve, and side vents must be used for process connections. A block manifold is not recommended for use with bottom port MVTs. Contact a Sensia field representative for assistance.

1. Verify that the meter is properly installed in the flow line (per manufacturer's instructions).
2. Mount the device to a 2-in. pipe using the mounting bosses on the side of the enclosure and a Sensia pole mount kit. See [Pole-Mounting the QRATE Scanner 3100, page 28](#) for detailed mounting instructions.
3. Install tubing and fittings to connect the high-pressure and low-pressure taps of the differential pressure meter to the process connections of the block manifold. Install a pair of shutoff valves near the high and low ports of the differential pressure meter. Use a suitable compound or tape on all threaded process connections.

4. Install the RTD assembly in the thermowell. Remove the plug from a conduit opening in the top of the enclosure, route the RTD assembly cable through the conduit opening and connect it to the terminal board. A wiring diagram for the RTD assembly is provided in [Figure 3.6, page 59](#). For hazardous areas, review [Hazardous Area Precautions, page 25](#).

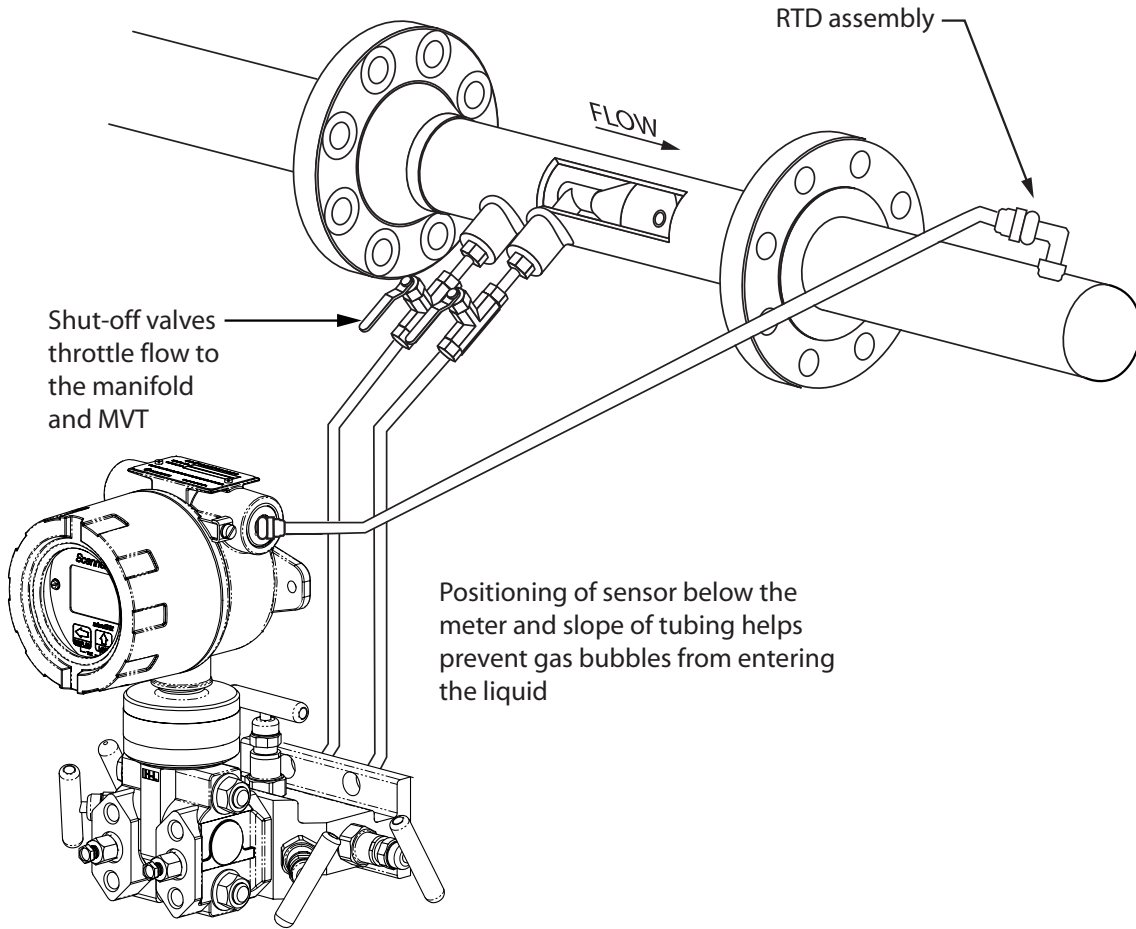

Figure 2.14—Remote-mount liquid cone meter run installation. The remote-mount method can be used with an orifice meter as well.

5. Route any additional inputs/outputs, communications connections, etc. through a conduit opening in the top of the enclosure. For hazardous areas, review [Hazardous Area Precautions, page 25](#).

Note	To prevent fittings from turning and/or to avoid putting tension on stainless steel tubing, use a backup wrench to attach stainless steel tubing to shut-off valves or sensor ports.
------	--

6. To eliminate air bubbles in the MVT, manifold and legs connecting them to the meter, fill the legs with fluid. Choose a fluid that is safe for the environment and stable when depressurized.

IMPORTANT	If the process fluid does not present an environmental risk and is stable when depressurized, it may be used to bleed air from the lines. If the process fluid can contaminate the environment or is highly volatile when depressurized as with liquefied gases, a different seal fluid should be used to fill the legs. An ideal seal fluid is one that does not dissolve in the process fluid.
-----------	--

7. If **process fluid** is to be used, bleed air from the lines as follows. If a different seal fluid is to be used, proceed to step 8.
 - a. Make sure the shut-off valves in the tubing near the meter pressure taps are closed, and the meter is filled with process fluid.

- b. Open the equalizer and bypass/block valves on the block manifold. Make sure the vent valve is closed.
 - c. Open one of the shut-off valves near the meter.
 - d. Slowly loosen the corresponding vent screw on the MVT, and throttle the rate of flow from the vent with the shut-off valve.
 - e. When air bubbles are no longer visible around the MVT vent, tighten the MVT vent screw.
 - f. Repeat steps 7a through 7e for the other leg.
 - g. Proceed to step 9.
8. If a fluid **other than the process fluid** is to be used, bleed air from the lines as follows:
- a. Make sure the shut-off valves in the tubing near the pressure taps are open.
 - b. Open the equalizer and bypass/block valves on the block manifold. Ensure the vent valve is closed.
 - c. Remove the vent screw from one side of the MVT and insert a fitting to allow connection of a hand pump or funnel. If a funnel is used, attach a length of Tygon tubing long enough to elevate the funnel well above the meter pressure taps to force the fluid up the legs.
 - d. Connect a hand pump or funnel to the fitting.
 - e. Estimate the amount of fill fluid required to fill the tubing and push any air bubbles into the meter.
 - f. Pour fill liquid into the funnel, tapping the tubing occasionally to dislodge any bubbles.
 - g. When the leg is full of fluid, remove the fitting from the MVT vent and quickly replace the vent screw and tighten.
 - h. Repeat steps 8a through 8g for the other leg.
9. Perform a manifold leak test as described in [Performing a Manifold Leak Test, page 50](#).
10. Verify the zero offset, if required (and other calibration points, if desired). See the QRATE Scanner 3100 Web Interface User Manual for complete instructions. See also [Zero Offset \(Static Pressure or Differential Pressure\), page 50](#), [Differential Pressure Calibration and Verification, page 52](#), and [Static Pressure Calibration and Verification, page 51](#).

CAUTION

Do not put the Scanner into operation until the valves are positioned properly so that pressure is supplied to both sides of the MVT. For instructions on proper valve positions, see [Placing the Scanner into Operation, page 53](#).

Measuring Compensated Liquid via a Turbine Meter

Best Practices

The QRATE Scanner 3100 calculates temperature- and pressure-compensated liquid flow through a turbine meter in accordance with API MPMS Ch. 11.1 and the measurement principles upon which the AGA 7 standard is based. When you supply a linear or multipoint calibration factor, the instrument performs the required compensation calculations based on the RTD and/or pressure inputs.

For optimum performance, ensure that the turbine and device installation complies with the industry recommendations listed below:

- Install the turbine flowmeter in the meter run such that there are at least 10 nominal diameters of straight pipe upstream and 5 nominal diameters of straight pipe downstream of the meter. Both inlet and outlet pipe should be of the same nominal size as the meter.
- Straightening vanes are recommended for eliminating swirl conditions. If used, they should be installed 5 diameters of straight pipe upstream of the meter. If a pressure transducer is installed, it is recommended that it be placed upstream of the flow straightener.

Performing a Manifold Leak Test

A manifold leak test is recommended prior to operating any differential pressure meter into service. Check the manifold for leaks as follows:

1. Verify that the instrument is approximately level and is properly connected to the pressure source.
2. Make sure the vent valve in the manifold is closed. (The bypass/block valves should be open.)
3. Close both bypass/block valves on the manifold to isolate pressure between the block valve and the MVT (Figure 2.15).
4. Open both equalizer valves to distribute pressure throughout.
5. Monitor the pressure readout and watch for a steady decrease in pressure.
6. If desired, spray all connections and valves with soapy water and observe for bubbling to detect the location of any leak(s). If leakage is indicated,
 - a. Depressurize the system by opening both bypass/block valves.
 - b. Check all manifold and piping joints.
 - c. Tighten connections and/or replace seals as necessary.
 - d. Repeat steps 3 through 6 to retest the manifold for leaks.
7. When the manifold is determined to be free of leaks, verify the condition of the equalizing valves as follows.
 - a. Close both equalizing valves and open the vent.
 - b. Monitor the differential pressure reading for any change.
8. Repair or replace the manifold as required if the differential pressure varies.

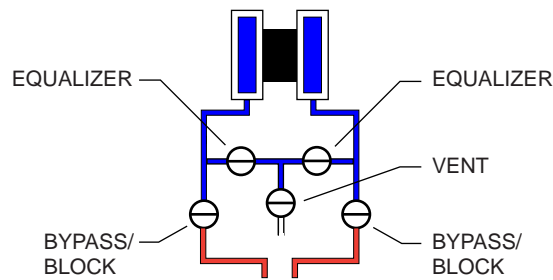

Figure 2.15—Valve positions for manifold leak test

Zero Offset (Static Pressure or Differential Pressure)

The static pressure input for the QRATE Scanner 3100 is zeroed at the factory before shipment. However, changes in temperature and atmospheric pressure can cause the static pressure and differential pressure readings to vary. The inputs can be easily zeroed in the field prior to putting the device into service, if necessary.

To zero the static pressure or differential pressure:

1. Close the bypass valves to isolate the pressure below the manifold (Figure 2.16, page 51).
2. Open the equalizer and vent valves.
3. Connect to the QRATE Scanner 3100 via the web interface.
4. Navigate to the *Local I/O>DP:Diff Pres* or *Local I/O>SP:Stat Pres* screen, click the **Zero Offset** tab, and click the **Modify** button. You will be prompted to enter the Maintenance mode. See the QRATE Scanner 3100 Web Interface User Manual for complete instructions.
5. Click the “Applied/As Left” field, enter 0.0, and wait for the reading to be acquired.

6. Click **Accept** to exit the dialog. The measured zero offset will be displayed on the screen.
7. Click **Save** to apply the offset to the device, and exit the Maintenance mode.

Note	Zero offset values are cleared when a new calibration is saved.
------	---

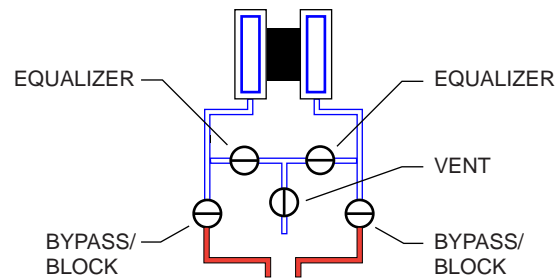

Figure 2.16—Valve positions for zero offset

Static Pressure Calibration and Verification

Note	The pressure range stamped on the MVT is expressed as psia (absolute). However, QRATE Scanner 3100 pressure inputs are recalibrated as psig (gauge) at the factory before the device is shipped. Therefore, default pressure readings displayed on the LCD and in the web interface are in terms of psig.
------	---

The static pressure and differential pressure inputs are calibrated and verified before the QRATE Scanner 3100 leaves the factory, and recalibration in the field may or may not be required. To comply with API standards for verification, “as found” readings should be recorded at approximately 0, 50, and 100 percent of the operating pressure range, increasing, and at 80, 20 and 0 percent of the operating pressure range, decreasing. For example, the static pressure measurements of a 1500-psi sensor should be verified at 0 psi, 750 psi, and 1500 psi, then at 1200 psi, 300 psi, and 0 psi.

	WARNING	Do not subject the QRATE Scanner 3100 to unnecessary shock or over-range pressure during maintenance operations.
--	----------------	--

To calibrate the static pressure:

1. Close the bypass valves to isolate the pressure below the manifold (Figure 2.17, page 52).
2. Open the equalizer valves and vent valve to purge the lines.
3. Close the vent valve.
4. Connect a static pressure simulator to either side of the manifold.
5. Connect to the QRATE Scanner 3100 via the web interface.
6. Navigate to the *Local I/O>SP:Stat Pres* screen, click the **Calibration** tab, and click the **Modify** button. You will be prompted to enter the Maintenance mode. See the QRATE Scanner 3100 Web Interface User Manual for complete instructions.
7. Click the “Applied/As Left” field, enter a known pressure.
8. Apply the same pressure to the MVT using the simulator and wait for the reading to be acquired.
9. Click **Accept** to accept the reading and exit the dialog. The pressure read by the simulator will be displayed in the As Found field and the calculated error between the pressure applied and the pressure read will appear beside it.
10. Repeat steps 7 through 9 to enter multiple calibration points.
11. When all calibration points have been entered, click **Save** to apply the new calibration settings.
12. Exit the Maintenance mode.

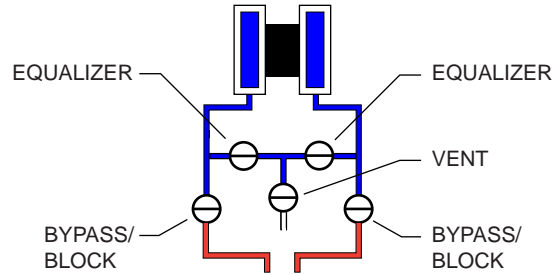

Figure 2.17—Valve positions for static pressure calibration

To verify the static pressure, perform the steps described in steps 6 through 12 above, except instead of clicking the **Calibration** tab, click the **Verification** tab. You will be prompted to enter an applied value, and you will apply the same pressure to the MVT, just as in the calibration process. The web interface will display a measured value and a percentage of error. When you click **Save**, the measured values are written to memory.

Note

Error is expressed as a percentage of the full scale of the MVT input range.

Differential Pressure Calibration and Verification

The static pressure and differential pressure inputs are calibrated and verified before the QRATE Scanner 3100 leaves the factory, and recalibration in the field may or may not be required. To comply with API standards for verification, “as found” readings should be recorded at approximately 0, 50, and 100 percent of the operating pressure range, increasing, and at 80, 20 and 0 percent of the operating pressure range, decreasing. For example, the differential pressure measurements of a 200 in. H₂O sensor should be verified at 0 in. H₂O, 100 in. H₂O, 200 in. H₂O, then at 160 in. H₂O, 40 in. H₂O, and 0 in. H₂O.



WARNING

Do not subject the QRATE Scanner 3100 to unnecessary shock or over-range pressure during maintenance operations.

To calibrate the differential pressure:

1. Close the bypass valves to isolate the pressure below the manifold (Figure 2.18, page 53).
2. Open the equalizer valves and vent valve to purge the lines.
3. Close the high-pressure side equalizer valve, leaving the low side vented.
4. Connect a pressure simulator to the high-pressure side of the manifold.
5. Connect to the QRATE Scanner 3100 with the web interface.
6. Navigate to the *Local I/O>DP:Diff Pres* screen, click the **Calibration** tab, and click the **Modify** button. You will be prompted to enter the Maintenance mode. See the QRATE Scanner 3100 Web Interface User Manual for complete instructions.
7. Click the “Applied/As Left” field, enter a known pressure.
8. Apply the same amount of pressure to the high side of the MVT using the simulator. and wait for the reading to be acquired.
9. Click **Accept** to accept the reading and exit the dialog. The pressure read by the simulator will be displayed in the As Found field and the calculated error between the pressure applied and the pressure read will appear beside it.
10. Repeat steps 7 through 9 to enter multiple calibration points.
11. When all calibration points have been entered, click **Save** to apply the new calibration settings.
12. Exit the Maintenance mode.

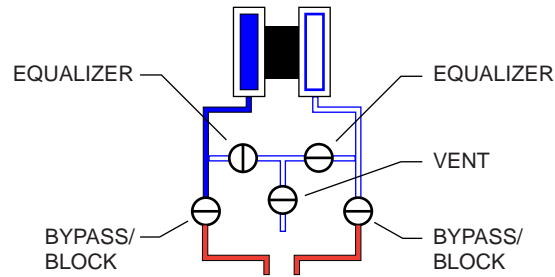

Figure 2.18—Valve positions for differential pressure calibration

To verify the differential pressure, perform the steps described in steps 6 through 12 above, except instead of clicking the **Calibration** tab, click the **Verification** tab. You will be prompted to enter an applied value, and you will apply the same pressure to the MVT, just as in the calibration process. The web interface will display a measured value and a percentage of error. When you click **Save**, the measured values are written to memory.

Note

Error is expressed as a percentage of the full scale of the MVT input range.

Placing the Scanner into Operation

To put the Scanner into operation:

1. Close the vent valve (Figure 2.19).
2. Open the equalizer valves.
3. Open the bypass/block valves to allow pressure to be supplied to both sides of the MVT.
4. Close the equalizer valves.
5. Open the vent valve (optional, you may choose to leave the vent closed).

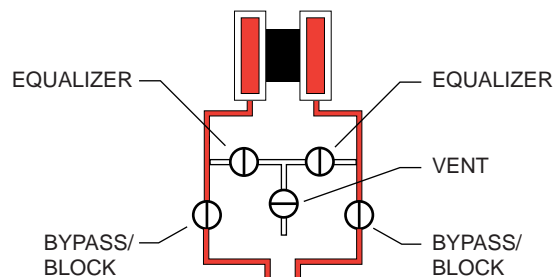

Figure 2.19—Valve positions for placing the Scanner into operation

This page intentionally left blank.

Section 3—Wiring the QRATE Scanner 3100

Field Wiring Connections



WARNING

Do not connect/disconnect equipment or change batteries unless the area is known to be non-hazardous. The QRATE Scanner 3100 poses no hazard when opened in a safe area.



CAUTION

All field wiring must conform to the National Electrical Code, NFPA 70, Article 501-4(b) for installations within the United States or the Canadian Electric Code for installations within Canada. Local wiring ordinances may also apply. All field wiring must be rated for temperatures of 90 °C or higher, and have a wire range of 22 to 14 AWG. Terminal block screws must be tightened to a minimum torque of 5 to 7 in-lb. (0.57 to 0.79 joules) to secure the wiring within the terminal block. Only personnel who are experienced with field wiring should perform these procedures.

To wire the QRATE Scanner 3100 for operation, complete the following field connections:

1. Remove the rear cover of the enclosure to access the terminal board. All wiring connections can be made to this board with the exception of the lithium batteries. Wire in accordance with the wiring diagrams shown on [page 58](#) through [page 65](#). See [Figure 3.1](#) for help in locating the terminals by number.

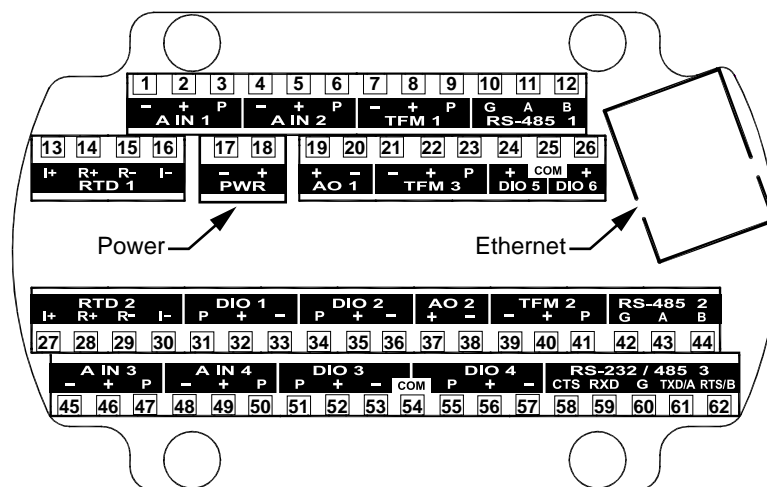

Figure 3.1—Terminal board illustration with numbered terminals

2. Complete wiring of the terminal board as follows:
 - a. Connect wiring for external power to PWR (Terminals 17 and 18), if desired.
 - b. If the device is externally powered, route the protective earth grounding conductor into the enclosure with the incoming power conductors and terminate it to the screw in the top of the enclosure ([Figure 3.2, page 56](#)). Alternatively, connect an earth ground conductor to the external stainless steel ground lug of the enclosure and to a ground rod or other suitable system earth ground, as shown in ([Figure 3.2, page 56](#)).



Figure 3.2—External and internal ground screw locations

- c. Connect the flowmeter input wiring to TFM 1, TFM 2, or TFM 3, as required.

Terminal Block	Terminals
TFM 1	7, 8, 9
TFM 2	39, 40, 41
TFM 3	21, 22, 23

- d. Connect the process temperature input wiring to RTD 1 or RTD 2, as required.

Terminal Block	Terminals
RTD 1	13, 14, 15, 16
RTD 2	27, 28, 29, 30

- e. Connect analog input wiring to A IN 1, A IN 2, A IN 3 or A IN 4, as required.

Terminal Block	Terminals
A IN 1	1, 2, 3
A IN 2	4, 5, 6
A IN 3	45, 46, 47
A IN 4	48, 49, 50

- f. Connect analog output wiring to AO 1 or AO 2, as required.

Terminal Block	Terminals
AO 1	19, 20
AO 2	37, 38

- g. Connect digital input/output wiring to DIO 1, DIO 2, DIO 3 or DIO 4, as required.

Terminal Block	Terminals	
DIO 1	31, 32, 33, 54 (COM)	Use 54 (COM) only with DIOs 1, 2, 3 and 4.
DIO 2	34, 35, 36, 54 (COM)	
DIO 3	51, 52, 53, 54 (COM)	
DIO 4	54 (COM), 55, 56, 57	
DIO 5	24, 25 (COM)	Use 25 (COM) only with DIOs 5 and 6.
DIO 6	25 (COM), 26	

- Configure and calibrate the QRATE Scanner 3100.
- Replace the enclosure cover.

Power Supply Wiring

Internal Power Supply

Sensia's 7.2 V lithium battery packs provide reliable backup power when used with an external primary power supply.

The QRATE Scanner 3100 supports up to two battery packs simultaneously. The battery compartment is located below the display/keypad assembly and is readily accessible when the front cover is removed from the enclosure.



WARNING

EXPLOSION RISK. Housing temperature must not exceed 70 °C (158 °F). Excessive temperatures, which could result from ambient conditions combined with radiated and conductive heat from the process, could cause the internal lithium battery to ignite or explode.

To determine which battery pack to change, look at the battery life indicator on the device display. See [Status Indicators \(Glyphs\)](#), page 79 and [Table 5.1—Device Status Glyph Definitions](#), page 80 for additional information.

To install a battery pack,

1. Insert the pack so that the cable end of the battery faces the back of the compartment.
2. Wrap the loose end of the cable toward the front of the compartment so that the connector is visible with the pack installed.
3. Locate the two receptacles on the back of the display board assembly ([Figure 3.3](#)).
4. Taking note of pin positions on the cable receptacle, slide the battery cable connector securely onto the pins of the receptacle nearest the battery pack.

Note

Proceed carefully when connecting the battery packs to the plastic receptacles to avoid damaging the connector or bending pins. Using a pair of needle-nose pliers to grasp the plastic battery cable connector may aid in aligning the connector and receptacle pins when connecting and disconnecting battery packs.

5. Repeat steps 1 through 4 to install the second battery pack.

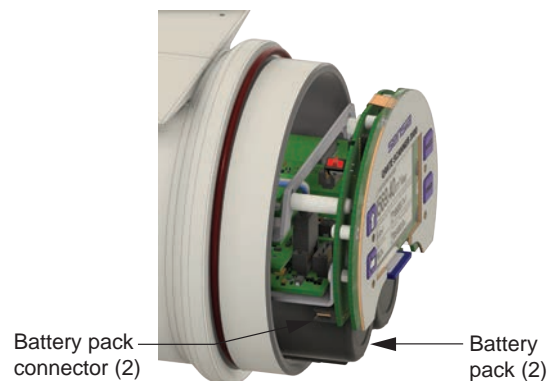

Figure 3.3—Lithium battery pack connectors (shown with enclosure removed from view)

Battery Life

Although external power is recommended for continuous use, the dual battery packs will autonomously power the QRATE Scanner 3100 for an estimated 2 to 3 weeks under a base load (no analog inputs, digital outputs, or Ethernet communication). Should the primary power supply fail, take the following precautions to maximize battery life:

- Ensure calculation frequency is no greater than once per minute.
- Ensure logging frequency (interval) is no greater than once per hour.
- Ensure download frequency is no greater than once per month.
- Avoid operating at extremely cold temperatures.
- Avoid the use of digital outputs (pulse or alarm).
- Avoid the use of analog inputs.
- Avoid the use of the Ethernet port (web interface access).
- Avoid powering an external transmitter with the device.

External Power Supply

The QRATE Scanner 3100 can be connected to a remote DC power supply (Figure 3.4). The power supply and cable must be capable of supplying 9 to 30 VDC at 210 mA minimum (9 to 24 VDC at 210 mA for installations in Mexico).

The external power supply used with CSA-approved units must be an approved SELV source, insulated from the AC main by double/reinforced insulation per CSA C22.2, No. 61010-1-04/UL 61010-1, 2nd Edition.

ATEX-approved devices should be powered with an external SELV power supply ($U_m = 30$ VDC) and an internal 7.8 V battery pack as backup, per ATEX Certificate Number Sira 15ATEX 1122X.



CAUTION

All field wiring must conform to the National Electrical Code, NFPA 70, Article 501-4(b) for installations within the United States or as specified in Section 18-156 of the Canadian Electrical Code for installations within Canada. Local wiring ordinances may also apply. All field wiring must have a wire range of 22 to 14 AWG and terminal block screws must be tightened to a minimum torque of 5 to 7 in-lb. to secure the wiring within the terminal block. Only personnel who are experienced with field wiring should perform these procedures.

IMPORTANT

In all applications using an external power supply, a switch or circuit breaker must be included in the safe area within easy reach of the operator. The switch or circuit breaker must be marked as the "disconnect" for the safe area external DC power supply.

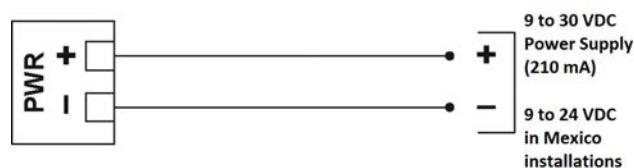

Figure 3.4—External power supply

Input Wiring

Turbine Flowmeter Inputs

TFM inputs 1, 2 and 3 on the terminal board provide the turbine flowmeter input signal generated by a magnetic pickup, enabling the QRATE Scanner 3100 to calculate and display instantaneous flow rates and accumulated totals. Wire as shown in [Figure 3.5](#).

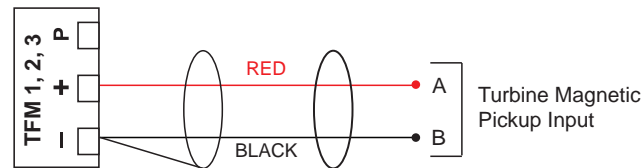

Figure 3.5—Flowmeter input

RTD Inputs

The 4-wire RTDs described in Appendix A of this manual are recommended for measuring temperature in temperature-compensated gas and liquid calculations, though a 2- or 3-wire RTD may prove functional. Wiring is essentially the same for all three models, though wire color may vary as indicated. Wire as shown in [Figure 3.6](#).

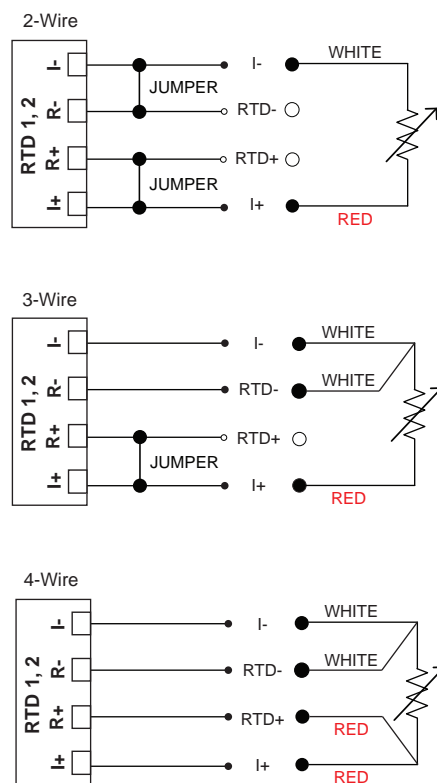

Figure 3.6—Process temperature input

Analog Inputs

The analog inputs (Figure 3.7), which can be configured for a 0 to 5 V, 1 to 5 V, 0 to 20 mA or 4 to 20 mA signal, can be used to receive readings from a pressure or temperature transmitter for use in any flow run. Alternatively, they can be used to log measurements from any device with a 0 to 5 V, 1 to 5 V, 0 to 20 mA or 4 to 20 mA output. An on-board resistor is automatically enabled when a current input is configured in the QRATE Scanner 3100 web interface. Therefore, no external resistor is required for use with a current input.

The device provides approximately 10 VDC at 20 mA for powering a 0 to 5 V or 1 to 5 V transmitter. It is not suitable for powering a 4 to 20 mA transmitter. For reduced power consumption, disable analog inputs in the QRATE Scanner 3100 web interface when they are not in use.

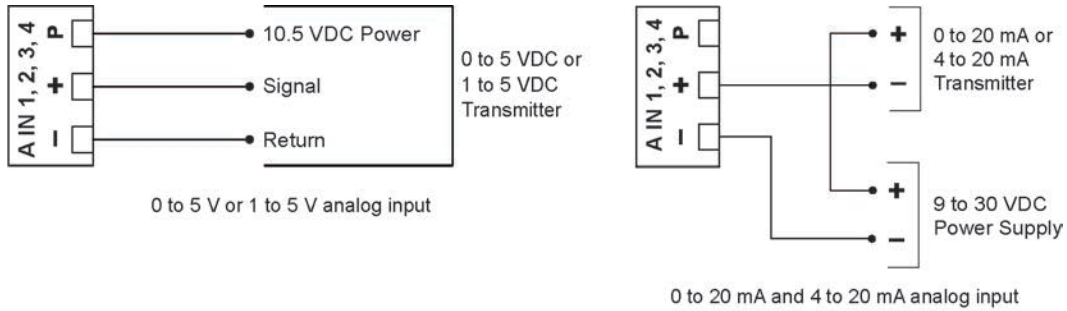

Figure 3.7—Analog input

Pulse Inputs

Pulse inputs (Figure 3.8) provide an input for high-amplitude pulse (frequency) signals, such as signals from a turbine meter equipped with a preamplifier (shown at left) or signals from a positive displacement meter (shown at right).

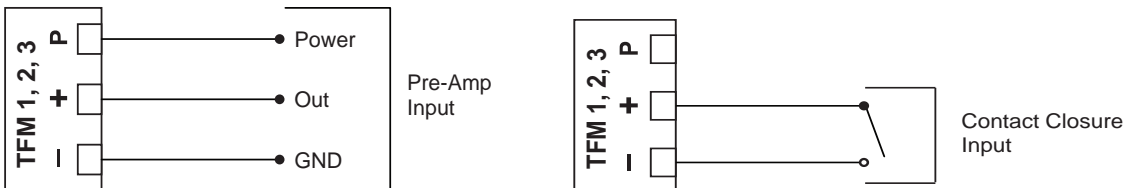

Figure 3.8—Pulse input

Digital Inputs—Contact Closure

The digital contact closure input (Figure 3.9, top) provides an input for use with any relay contact switch. DIO 1 through DIO 4 are optically isolated. DIO 5 and DIO 6 (Figure 3.9, bottom) are non-isolated. To configure a contact closure using the QRATE Scanner 3100 web interface, choose **Contact Closure** as the input type and select a trigger state to indicate whether the pulse will trigger when the signal is high or when it is low.

Note	Digital input/output common (COM) connections are not interchangeable. The COM connection located between DIO 3 and DIO 4 terminals cannot be used with DIO 5 and DIO 6 wiring and vice versa. The COM connections between DIO 3 and DIO 4 terminals contains a 3.6 kΩ resistor to circuit ground. The COM connection between DIO 3 and DIO 4 terminals can be used with DIOs 1 through 4.
------	--

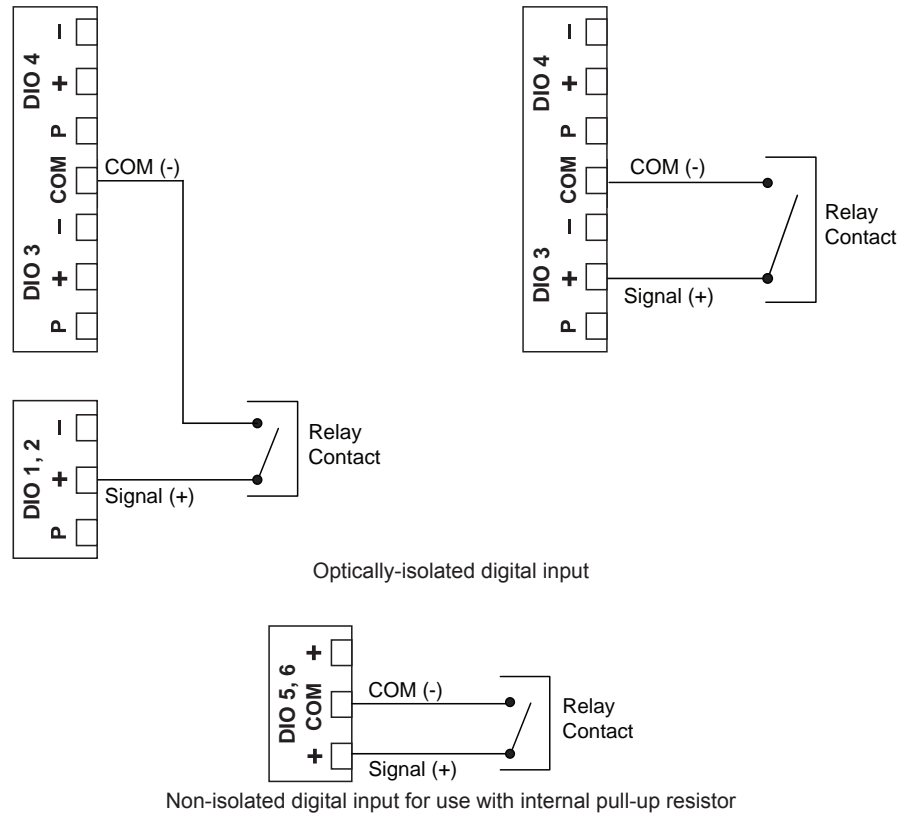

Figure 3.9—Digital contact closure

Digital Inputs—Pulse

The digital pulse input (Figure 3.10) provides an input for use with any 3 to 30 VDC pulse-generating device. DIOs 1 through 4 (shown at left) are optically isolated. DIOs 5 and 6 (shown at right) are non-isolated.

To configure a pulse input using the web interface, choose **Pulse** as the input type, and select a trigger state to indicate whether the pulse will trigger when the signal is high or when it is low.

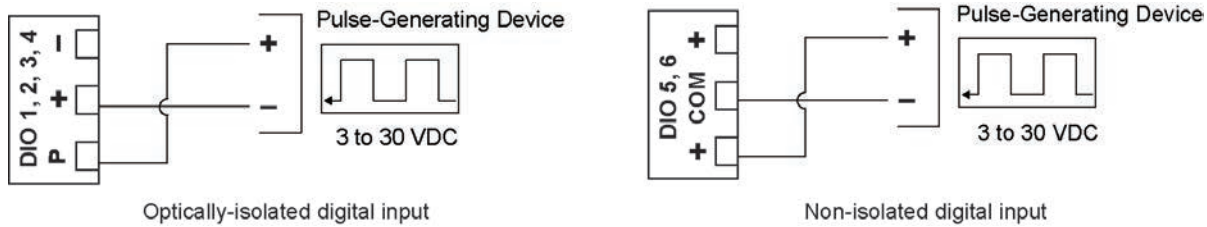

Figure 3.10—Digital pulse input

Digital Inputs—Open Collector

The digital open collector input (Figure 3.11) provides an input for use with any device with an open collector output. DIOs 1 through 4 (top) are optically isolated. DIOs 5 and 6 (bottom) are non-isolated and can be wired for use with an internal pull-up resistor, or with a customer-supplied resistor. When the internal pull-up resistor is used, signals can be transmitted over short distances without the use of an external power supply.

To configure an open collector input using the web interface, choose **Open Collector** as the input type, and select a trigger state to indicate whether the input is to trigger when the signal is high or when it is low.

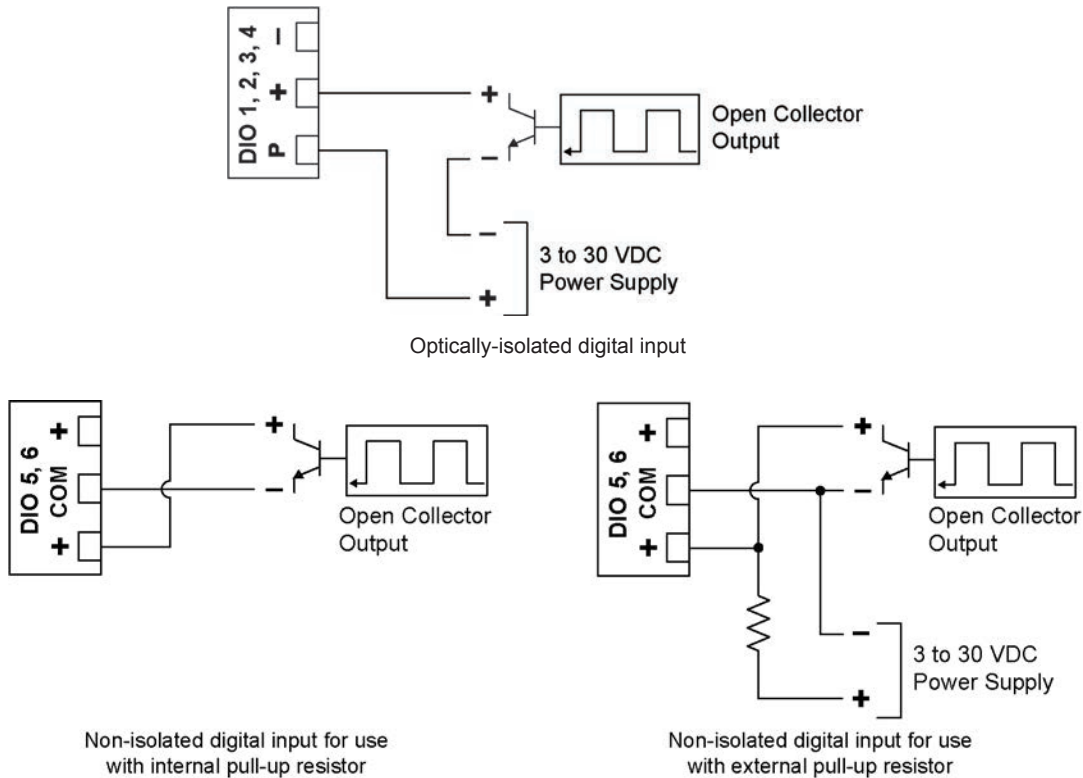

Figure 3.11—Digital open collector input

Output Wiring

Analog (4 to 20 mA) Outputs

The 4 to 20 mA output (Figure 3.12) provides a linear current output that can be configured to represent any parameter in the holding registers using the QRATE Scanner 3100 web interface. This output requires a two-conductor cable connected to a 9 to 30 VDC power supply (voltage required is dependent on loop resistance) and a current readout device located in the remote location. The analog outputs are electrically isolated from each other and from the main electronics. See the QRATE Scanner 3100 Web Interface User Manual for information on configuring and calibrating zero and full-scale values.

The load resistance vs. loop supply voltage graph below shows the minimum voltage required to power the instrument for a given loop resistance. In addition, the mathematical relationship between loop voltage and load resistance is given. For example, if a power supply voltage of 24 volts is available to power the current loop, the maximum load resistance would be 800 ohms.

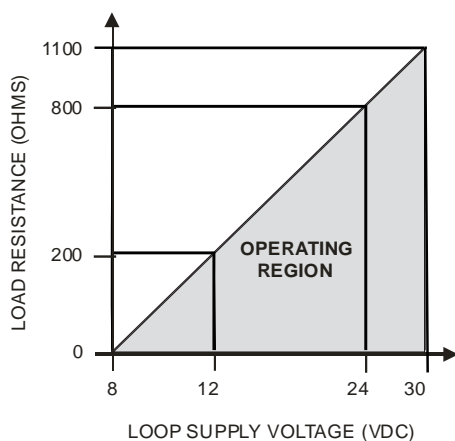
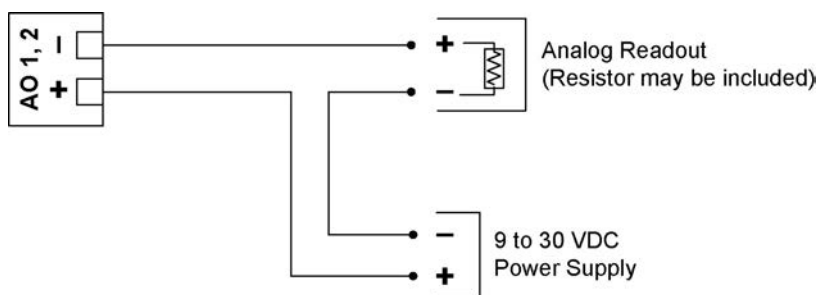

$$R_L \text{ MAX} = \frac{(V \text{ loop} - 8V)}{20 \text{ mA}}$$

$$R_L \text{ MAX} = \frac{(24V \text{ loop} - 8V)}{20 \text{ mA}}$$

$$R_L \text{ MAX} = 800 \text{ ohms}$$

Figure 3.12—Analog (4 to 20 mA) output

Digital Outputs

The standard QRATE Scanner 3100 supports six solid-state digital outputs that are configurable as pulse outputs, alarm outputs, conditional outputs, or programmed outputs using time of day or an output state as the trigger.

DIO 1 through DIO 4 are isolated and rated for a maximum of 60 mA at 30 VDC. Maximum frequency is 50 Hz. Wire as shown in Figure 3.13 (top diagram). Because the circuit is isolated, it can be used with any other feature on the device. A two-conductor cable from the device to the remote location is required.

DIO 5 and DIO 6 are designed for handling significantly higher currents and can be used to control power to another device. Wire as shown in Figure 3.13 (bottom diagram). These terminals are rated for a maximum of 500 mA at 30 VDC. Maximum frequency is 50 Hz.

For reduced power consumption, disable digital outputs using the QRATE Scanner 3100 web interface when they are not in use.

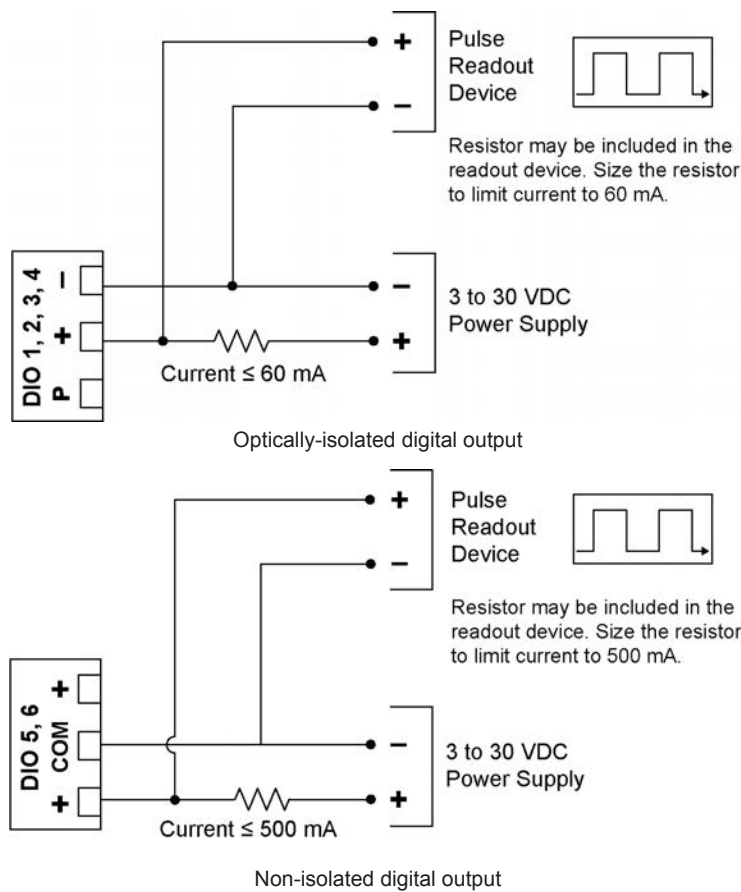

Figure 3.13—Pulse output wiring

Communications

RS-485 Communications

The QRATE Scanner 3100 supports digital serial communications using EIA-RS-485 hardware with Modicon Modbus protocol. RS-485 communications are supported by three ports with a baud range of 300 to 115.2K. Ports 1, 2, and 3 can be used simultaneously, if desired, and all three ports are protected from high-voltage transients. The circuit can be terminated by enabling an internal termination resistor in the web interface. See the QRATE Scanner 3100 Web Interface User Manual for details. Wire as shown in [Figure 3.14](#).

Ports 1 and 2 (shown at left) are designed for use with low-power peripherals such as radios, gas chromatographs, other wired Modbus devices, and wired Scanner slave devices, and are always enabled. If a large number of slave devices are to be connected to the device's network via a serial port, more than one communication port may be required, depending on archive periods and baud rates desired.

Port 3 (shown at right) supports both RS-485 and RS-232 communications and may be preferred for continuous, high-speed communications. Port 3 is disabled by default, and must be enabled before use. The mode (RS-485 or RS-232) is automatically detected by the hardware.

Note	Not all RS-485 devices, including converters, identify A and B terms consistently. If communications are not established, switch the wires.
------	---

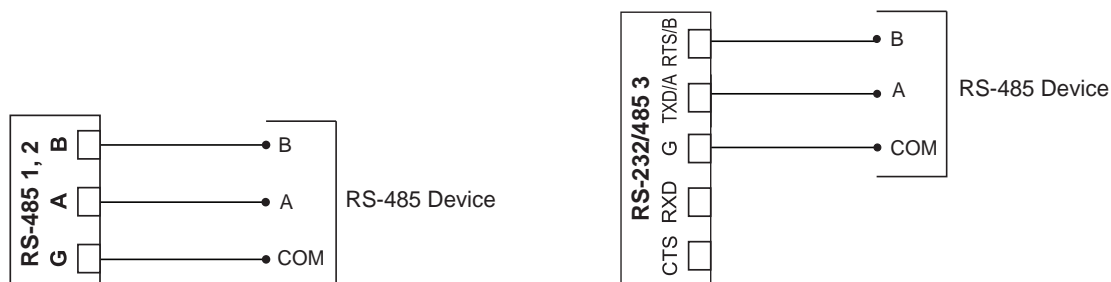

Figure 3.14—RS-485 communications



WARNING

To prevent ignition of hazardous atmospheres, do not remove the QRATE Scanner 3100 cover while circuits are alive. The QRATE Scanner 3100 poses no hazard when opened in a safe area.

RS-232 Communications

RS-232 communications are supported by Port 3, a high-power port that also supports RS-485 communications. RS-232 communications are useful for short-range communications (typically 50 ft or less) with radios and some Modbus peripheral devices. Wire as shown in [Figure 3.15](#). Port 3 must be enabled and configured for RS-485 or RS-232 communications via the web interface.

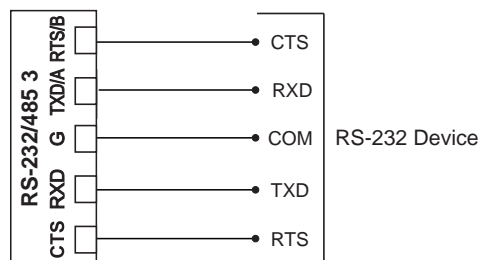

Figure 3.15—RS-232 communications

Ethernet Communications

An RJ-45 connector ([Figure 3.1, page 55](#)) provides the Ethernet communications required for accessing the web interface via a web browser and for transmitting data over two TCP ports. The TCP ports support Modbus TCP and Modbus-over-TCP protocols and can be configured individually (assigned to unique port numbers) using the web interface.

Section 4 describes two methods for using the Ethernet port to connect the QRATE Scanner 3100 to a PC or laptop.

Section 4—Connecting to the QRATE Scanner 3100 Web Interface

To connect to the QRATE Scanner 3100 interface, you will need to establish a local area network between your computer (PC or laptop) and the Scanner using Ethernet cables and possibly, a router. An IP address will be assigned to the device during this process. You can then enter the IP address into the address bar of any web browser to login to the device interface.

You can access the web interface from any laptop, tablet, or smart phone equipped with a web browser.

This section describes IP address options and three methods for establishing a local area network with the QRATE Scanner 3100 integrated control flow computer.

Note	To download software or user documentation, visit sensiaglobal.com/Measurement . Scroll to select FLOW COMPUTING AND AUTOMATION , then click QRATE SCANNER 3000 SERIES INTEGRATED CONTROL FLOW COMPUTERS and click the link for the desired software installation or user manual.
IMPORTANT	The QRATE Scanner 3100 web interface requires JavaScript to be enabled. For instructions about enabling JavaScript in the 5 most commonly used web browsers, see http://www.enable-javascript.com/ .
IMPORTANT	Before attempting to connect to the QRATE Scanner 3100, check with your Information Technology (IT) department to determine the best method of connection, review relevant company policies, and obtain permission before attempting to add the device to a corporate network infrastructure.

IP Address Options

The QRATE Scanner 3100 accommodates both dynamic and static IP addresses.

Dynamic IP is considered the least restrictive means of supporting communications with the Scanner, and is often preferred by corporations with extensive IP needs. However, you should be aware that dynamic IP addresses are subject to change over time (the frequency of such changes is controlled by corporate network settings). If the device is to be installed in a remote location, a dynamic IP address may not be the most reliable choice.

Static IP addresses are unchanging, which helps protect user access to the device but restricts the address from being used with any other device. A static IP address may be a consideration if you must access the device from a great distance and do not have a local contact near the device who can verify the IP address from the device display.

Note	Static IP addresses can be disabled during firmware upgrades, requiring onsite assistance to restore the static IP address.
------	---

Dynamic IP is recommended for initial setup of the device. Once communication with the device is achieved, a static IP address can be assigned, if applicable. Basic instructions for changing an IP address are provided in the QRATE Scanner 3100 Web Interface User Manual linked to the web interface. step-by-step instructions may vary with web utilities and computer operating systems. If you are unfamiliar with this process, seek assistance from an IT professional.

IMPORTANT	The following instructions will help guide you through an initial connection to the QRATE Scanner 3100 using the Scanner's dynamic IP address. If a static IP address is required for ongoing Scanner communications, the IP can be reconfigured in the web interface after this initial connection. See the static IP configuration instructions in the QRATE Scanner 3100 Web Interface User Manual for details.
-----------	--

Connection Options

A computer can be connected to a QRATE Scanner 3100 using either of two methods:

- **Direct (1 to 1) Connection (Ethernet Only).** This method is recommended only if you have experience changing Windows settings and have the administrative rights to assign a static IP address to your computer.
- **Standard Connection (Ethernet and WiFi).** This method requires no changes to computer settings and is typically the easiest connection method for novice users. Three different types of connections are supported by the device:
 - Add the device to an existing corporate network (contact your IT professional for assistance)
 - Create an ad hoc network using a wireless router (for locations without an external power supply, Sensia recommends the use of a portable router)
 - Create a permanent local network using the internal antenna or external WiFi module and antenna

Direct (1-to-1) Connection to a Laptop

To establish a direct connection between the QRATE Scanner 3100 and a laptop, perform the steps below.

1. Obtain the following hardware:
 - External power supply
 - Ethernet cable (cross-over or straight CAT 5 or greater)
2. Remove the rear enclosure cover and connect the power supply to the power terminal (see [External Power Supply, page 58](#) for detailed instructions). Allow approximately one minute for the device to boot.



WARNING

To prevent ignition of hazardous atmospheres, do not remove the QRATE Scanner 3100 cover while circuits are alive. The QRATE Scanner 3100 poses no hazard when opened in a safe area.

3. If the device has the factory default dynamic IP address, navigate to the laptop's Control Panel settings and change the IP address of the laptop to [192.168.0.XXX](#) where "XXX" is any number sequence other than "040." If the IP address of the device has been changed to a static IP address, change the IP address of the laptop to match the current static IP address, changing the last three digits as required. Ensure that the laptop uses the same subnet and differs only in the last three digits.
4. Connect the Ethernet cable to the RJ-45 connector on the device terminal board and to the laptop Ethernet port.
5. Open a web browser on the laptop and enter the IP address shown at the top of the Scanner display. Press "Enter" and wait for the *Device Login* screen to load.
6. On the *Device Login* screen, enter the appropriate user name and password. Default entries (case-sensitive) are:
 - User Name: admin**
 - Password: scanner**
7. Press the "Login" button on the screen.

IMPORTANT

Changing the administrative password after the initial login is strongly recommended. See the "Security" section of the QRATE Scanner 3100 Web Interface User Manual for instructions on changing the administrative password and setting up additional users with password-protected access.

Ad-Hoc Wireless Router Connection

If you have no wireless access point or work for a company that does not wish to add another device to the corporate Ethernet network, a portable wireless router can be used to establish a local area network. Routers with a single LAN port must be used with a wireless-enabled laptop. Multi-port wireless routers can be used to establish a wireless connection using any standard laptop with or without wireless capabilities.

IMPORTANT	Sensia supports only select third-party portable wireless routers that are compatible with the Windows 7 operating system and are IEEE 802.11 compliant. Contact your local Sensia representative for a list of supported routers.
------------------	--

To establish the QRATE Scanner 3100's connection to a laptop via a wireless router, obtain the following hardware:

- External power supply (for USB-powered routers, a USB cable connected to a computer provides this supply)
- Router with one or more LAN ports
- One or two Ethernet cables (cross-over or straight CAT 5 or greater)
 - One cable for routers with a single LAN port (for use with a wireless communications-enabled laptop)
 - Two cables for routers with multiple LAN ports

If the selected router has only one LAN port (as with many portable routers), wireless communications must be used to connect to the laptop. In this instance, the laptop must have wireless capabilities to match router specifications. See [Single-Port Router Option \(Requires Wireless-Enabled Laptop\)](#), for setup instructions.

If the selected router has multiple LAN ports, see [Multi-Port Router Option, page 70](#) for setup instructions.

Single-Port Router Option (Requires Wireless-Enabled Laptop)

1. Identify the router's IP address, user name, and password in the router manufacturer literature.
2. Enable wireless communications on the laptop.
3. Boot the router using the following procedure:
 - a. Connect power to the router with the supplied power source. If using a USB-powered router, connect the USB power cable to the laptop and to the router to power the router from the laptop. If using a battery-powered router, turn on the router.
 - b. Wait approximately 20 seconds.
 - c. Connect an Ethernet cable to the laptop and to the router LAN/WAN port.
4. Obtain wireless network information using the following procedure:
 - a. Open the laptop browser, enter the router's IP address, and press "Enter."
 - b. At the login prompt, enter the router's user name and password and click **OK** to display the router home page.
 - c. Record the SSID, security type, encryption type, and pre-shared security key for your wireless network. This information is found in router's manufacturer instructions and is required to complete step 5.
 - d. Close the web browser and disconnect the Ethernet cable from the router and the laptop.
5. Configure the wireless network as follows:
 - a. Enable wireless communications on the laptop.
 - b. From the laptop's Control Panel, access the *Wireless Network Configuration* utility.
 - c. Choose **Add** in the Wireless Network Management Tool.

- d. Select **Manually create a network profile**.
 - e. Enter the wireless network information recorded in step 4c.
 - f. Select **Start this connection automatically** and click **Next**.
6. Click the “Wireless Communication” icon on the *Quick Access* tray at the bottom of the laptop screen. If you cannot see the icon, expand the *Quick Access* tray.
 7. From the list of wireless networks connected, select the wireless network you created and click **Connect**.
 8. Proceed to [QRATE Scanner 3100 Network Connection](#) below.

Multi-Port Router Option

If the router in use has multiple LAN ports, proceed as follows:

1. Boot the router by performing the following tasks.
 - a. Connect power to the router using the supplied power source. If using a USB-powered router, connect the USB power cable to the laptop and to the router to power the router from the laptop.
 - b. Wait approximately 20 seconds.
 - c. Connect an Ethernet cable to the laptop and to one of the router LAN ports.
2. Proceed to [QRATE Scanner 3100 Network Connection](#) below.

QRATE Scanner 3100 Network Connection

To connect the QRATE Scanner 3100 to the local area network (LAN), use the following procedures.

1. Remove the rear enclosure cover and connect the power supply to the power terminal. The device will take approximately one minute to boot.
2. Connect an Ethernet cable to the terminal board’s RJ-45 connector and to the router’s LAN port. The device will detect the network automatically.
3. Record the device’s IP address displayed in the upper left corner of the LCD display.
4. Open a web browser, type the device’s IP address in the address bar, and press “Enter” on the keyboard or keypad of your device.
5. On the *Device Login* screen, enter the appropriate user name and password. Default entries (case-sensitive) are:

User Name: admin
Password: scanner
6. Press the “Login” button on the screen.

Note	If the loading stalls, click Refresh . If a connection to the Scanner is not established, verify the IP address and repeat step 4.
IMPORTANT	Changing the administrative password after the initial login is strongly recommended. See the “Security” section of the QRATE Scanner 3100 Web Interface User Manual for instructions on changing the administrative password, and setting up additional users with password-protected access.

WiFi Communications Accessory

The WiFi communications accessory (“WiFi box”) provides wireless access to the QRATE Scanner 3100 via the web interface and a permanently installed wireless modem. The WiFi box is externally powered and can be accessed by multiple users. It also allows users to communicate to the device from a safe distance outside a Class I, Div. 1 area for compliance with hazardous area safety regulations. In most cases, the internal WiFi module and antenna will be sufficient.

The WiFi solution includes a wireless modem, modem power supply, and internal antenna cable/lightning arrester assembled inside a weatherproof Class I, Div. 2 enclosure and an external remote-mount antenna with pole-mounting hardware. A 10-ft antenna cable and an Ethernet/power bundled cable (5, 10, 20 or 30 feet) are optionally available for purchase. Alternatively, the WiFi module may use the internal antenna.

Note	A user-supplied external 110/240 VAC, 50/60 Hz power supply is required to power the WiFi box.
------	--

The WiFi box is pre-assembled and the router is pre-configured at the factory. Field wiring is limited to power connections to the box and to the device and an Ethernet connection to the device.

Installation

The WiFi box is approved for mounting in Class 1, Div. 2, Group A, B, C, or D locations. Select a suitable location in a safe area at least 3 feet from any Class 1, Div. 1 area and free of physical obstructions.



WARNING

To avoid personal injury and property damage, ensure the antenna is clear of any overhead power lines.

The WiFi box is preassembled at the factory ([Figure 4.1](#)) and ships with:

- One pair of installed fuses
- One pair of spare fuses
- Hardware for mounting to a vertical pipe or to a flat vertical surface
- An external 31.5-in. antenna with pole-mounting hardware
- A 10-ft antenna cable (if longer lengths are required, 20-ft and 30-ft cable can be ordered separately)



Figure 4.1—Interior of WiFi Communications box

Pole Mount

To mount the WiFi box on a vertical pipe or pole, position the U-bolts around the pipe and secure them to the integral brackets on the WiFi box using the nuts provided (Figure 4.2).

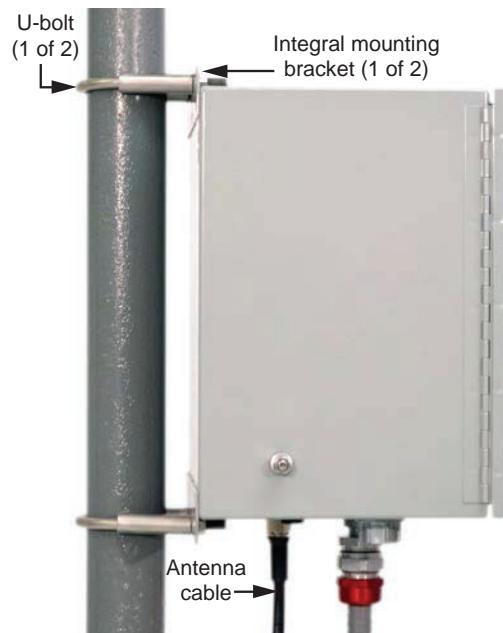

Figure 4.2—WiFi box mounted on a 2-in. pole

Bulkhead Mount

To mount the WiFi box to a flat vertical surface,

1. Dry-fit the WiFi box and mark screw locations using the outside holes on the top and bottom of the WiFi box integral mounting brackets.
2. Secure the box in place using the screws provided.

Antenna Mount

The antenna must be mounted in a vertical position with the metal base closest to the ground. The antenna connector at the base of the antenna must be no more than 10 feet from the antenna connector on the bottom of the WiFi enclosure to accommodate the 10-ft antenna cable.

If the antenna will be mounted to a 2-in. pipe with a 2 3/8-in. OD, an alternate 2-in. pipe bracket must be used in place of the standard bracket (Figure 4.3, page 73).

To install the antenna,

1. Determine the mounting location and verify that the 10-ft cable will connect to the WiFi box from that location.

- Position the U-bolts around the pipe and secure to the mounting bracket with the nuts provided.



Figure 4.3—(Left) Standard antenna mounting bracket for outside pipe diameters up to 2-in. and (right) alternate antenna mounting bracket for outside pipe diameters of 2.375-in.

Wiring the WiFi Box



WARNING

Before attempting any wiring, ensure that all power is disconnected. Failure to disconnect main service power to the WiFi box can cause severe personal injury, death, or substantial property damage. Before reapplying power, ensure that all wiring connections are secure and connected properly.



CAUTION

All field wiring must conform to the National Electric Code, NFPA 70, Article 501-4(b) for installations within the United States or as specified in Section 18-156 of the Canadian Electrical Code for installations within Canada. Local wiring ordinances may also apply. All field wiring must have a wire range of 22 to 14 AWG and insulation rated for 120 VAC or above and copper or copper-clad aluminum conductors. Terminal block screws must be tightened to a minimum torque of 5 to 7 in-lb to secure the wiring within the terminal block. Only personnel who are experienced with field wiring should perform these procedures.

The instrument must be grounded with a protective earth grounding conductor in accordance with national and local electrical codes.

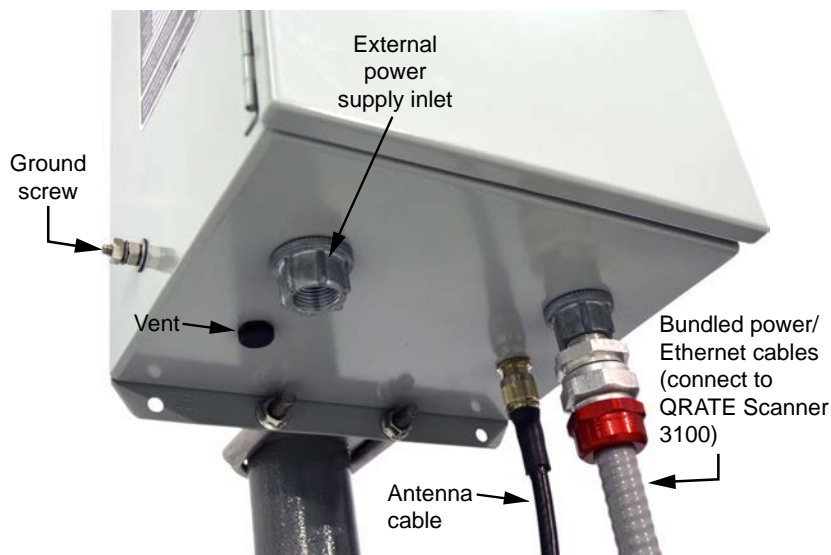

Figure 4.4—Exterior of WiFi box showing location of connectors and external ground screw

To wire the WiFi box for operation, perform the following steps:

1. Open the door of the WiFi box and open the F1 and F2 fuse housings on the power block (Figure 4.5). Fuse F1 opens from the top. Fuse F2 opens from the bottom.
2. Connect a ground wire to the external ground located on the bottom left side of the WiFi box (Figure 4.4, page 73).
3. Disconnect the external power supply that will power the WiFi box using a disconnect breaker switch or other means of locking out power.
4. Attach the antenna to the WiFi box as follows:
 - a. Connect the black antenna cable to the antenna connection located on the bottom of the box behind the Ethernet connection hub as shown in Figure 4.4, page 73.
 - b. Twist the antenna connector clockwise to tighten.



WARNING

Do not connect/disconnect equipment unless the area is known to be non-hazardous. The QRATE Scanner 3100 poses no hazard when opened in a safe area.

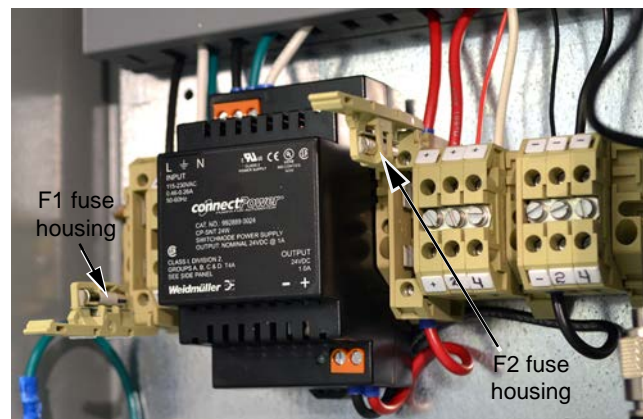

Figure 4.5—F1 and F2 fuse housing, opened

Connect the device to the WiFi box as follows:

- c. Remove a conduit port plug from the enclosure.
- d. Remove the rear lid of the enclosure to access the terminal board (Figure 4.6).

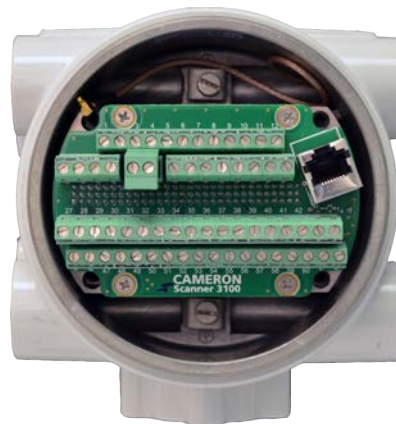

Figure 4.6—Rear view of QRATE Scanner 3100 showing terminal board

- e. To free up space for pulling wires through the conduit port, unseat the terminal board by unscrewing the four Phillips screws holding it in place and gently pulling the board straight back to disconnect it from its connected header without bending pins. Do not attempt to completely remove the board from the enclosure. Doing so could damage a SATA cable attached to the back of the terminal block. Allow the board to rest terminal-side up along the bottom edge of the enclosure.
- f. Thread the Ethernet and power wires shown in [Figure 4.7](#) through the conduit opening in the enclosure and tighten the cable connector in the conduit opening.
- g. Connect the Ethernet cable to the Ethernet port on the device terminal board (shown in [Figure 4.8](#)).

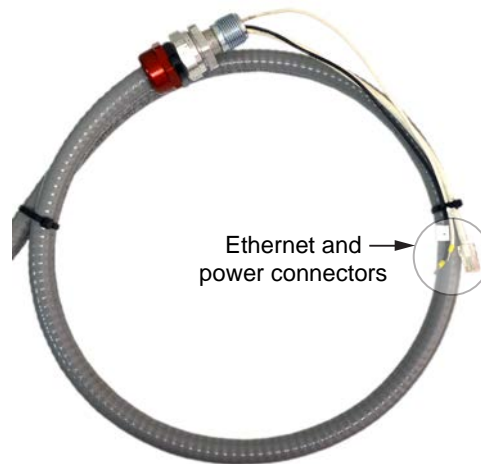

Figure 4.7—Ethernet and power conductors connecting the WiFi box to the QRATE Scanner 3100

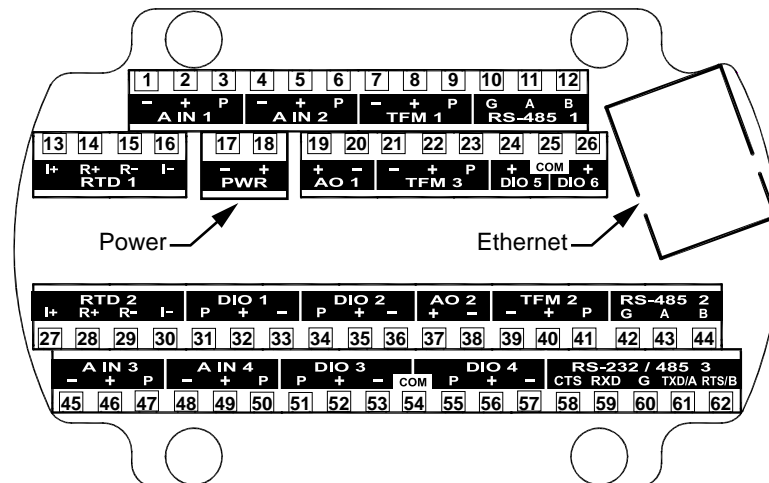

Figure 4.8—Terminal board illustration showing Ethernet port and Power terminal block location

- h. Wire white (+) and black (-) power wires to the device PWR terminal block (shown in [Figure 4.8](#)).
 - i. Reseat the terminal block in the enclosure, carefully aligning the pins on the back with the underlying header, and replace the four screws removed in step 4e.
 - j. Replace the enclosure lid.
5. With the external power still off, connect the 110 VAC external power supply to the WiFi box as follows:

- a. Thread the external power supply wires through the conduit hub on the bottom of the WiFi box (Figure 4.4, page 73).
- b. Tighten the power supply cable connector.
- c. Verify that the F1 and F2 fuse housings on the power block are open (Figure 4.8, page 75).
- d. Wire the external power supply to the designated terminal blocks (H, N, GND) as shown in Figure 4.9.

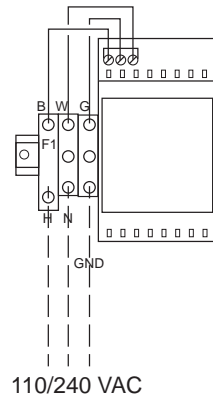

Figure 4.9—WiFi box external power supply wiring diagram

6. Restore the external power that was disconnected in step 3 to initiate power to the WiFi box.
7. Close the F1 fuse housing (Figure 4.10) to bring power into the box. The green indicator light on the modem power supply will come on to indicate that the fuse is working correctly.

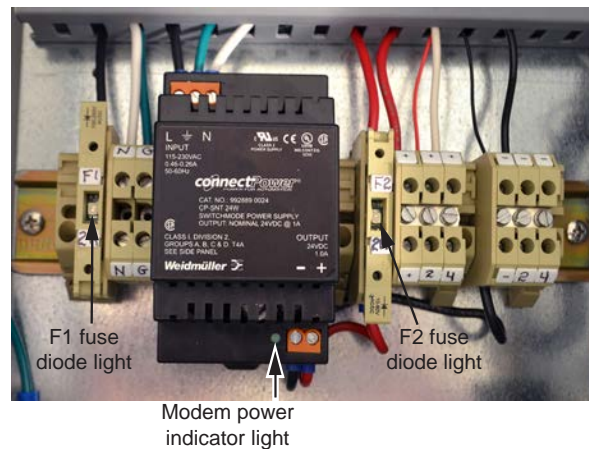

Figure 4.10—F1 and F2 fuse housing, closed

8. Close the F2 fuse (Figure 4.10) to supply power to the modem and the connected device.
9. Verify that the modem indicator lights are illuminated (Figure 4.11). If no lights are visible, check the diode light in the middle of the fuse housing (Figure 4.10). If it is lit, the fuse is blown and must be replaced.



Figure 4.11—Location of modem indicator lights

Connecting to the QRATE Scanner 3100

The WiFi modem is pre-configured at the factory to expedite user setup in the field. To connect to the QRATE Scanner 3100 web interface via the WiFi accessory,

1. Apply 110 VAC power to the modem. The modem will begin broadcasting its wireless signal momentarily.
2. From a laptop or other browser-enabled device, click on the “IPn4G+” wireless connection to connect to the WiFi modem.
3. Locate and record the IP address displayed in the upper left corner of the Scanner’s LCD display.
4. Open a web browser on the laptop or other browser-enabled device and enter the IP address. The web interface *Device Login* page will appear.
5. On the *Device Login* page, enter the appropriate user name and password. Default entries (case-sensitive) are:
User Name: admin
Password: scanner
6. Press the “Login” button on the screen.

Note	If the loading stalls, click Refresh . If a connection to the Scanner is not established, verify the IP address and repeat step 4.
IMPORTANT	Changing the administrative password after the initial login is strongly recommended. See the “Security” section of the QRATE Scanner 3100 Web Interface User Manual for instructions on changing the administrative password and setting up additional users with password-protected access.

Troubleshooting the Wireless Connection

If the modem fails to communicate with the QRATE Scanner 3100, consider the following steps to address the problem:

1. Open and close fuse F2 inside the WiFi box to reboot the modem.
2. Shut off the laptop and restart it.
3. If the modem is powered, but no wireless connectivity is detected on your computer or other browser-enabled device, it may be necessary to reset the device’s IP address. Please contact Sensia technical support for assistance.

Adding Security to the WiFi Connection

WiFi security is disabled at the factory during initial modem configuration, but users can enable security by logging into the modem web browser menu, as follows.

1. Open a web browser on a laptop or smartphone.
2. Enter the modem’s IP/port address, 192.168.168.1:8080.
3. When prompted, enter the following user name and password to access the main modem screen:
User Name: admin
Password: admin
4. Click the **Wireless** tab in the top bar, and the **Radio 1** tab from the second bar at the top of the screen.
5. From the **Radio 1** tab, locate the “Encryption Type” field near the bottom of the screen.
6. Select an encryption type from the dropdown list.
7. Enter a password if desired, and click **Submit**.

This page intentionally left blank.

Section 5—Display and Keypad Operations

The QRATE Scanner 3100 display and keypad allows you to view the real-time measurements for up to 32 selected parameters, 5 at a time. By default, the parameters scroll continuously through the 5 fields provided (Figure 5.1). In a declassified or safe area, you can use the keypad to manually pace the display. To access the keypad, remove the cover of the explosion-proof enclosure.



WARNING

To prevent ignition of hazardous atmospheres, do not remove the cover while circuits are alive. The QRATE Scanner 3100 poses no hazard when opened in a safe area.

IP Address

The IP address used to connect with a QRATE Scanner 3100 via the web interface is displayed at the top of the LCD. The IP address is assigned when a user connects to the device for the first time using a computer or other browser-enabled device. If no address appears in the display, check for a problem with the Ethernet connection.

Status Indicators (Glyphs)

When power is applied to the device, a row of pictorial status indicators or “glyphs” appears in the top right corner of the LCD. You can use these glyphs to quickly assess the status of the LCD display, wireless connectivity, power connectivity, and battery capacity once you become acquainted with the symbols and their meanings (Figure 5.1 and Table 5.1—Device Status Glyph Definitions, page 80).

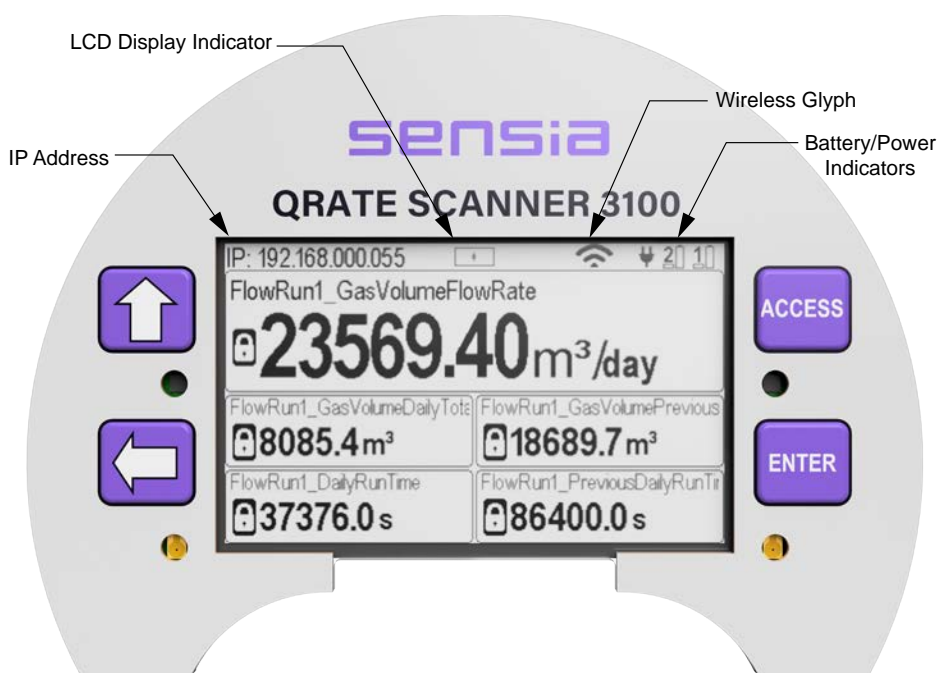

Figure 5.1—LCD display components

Additionally, glyphs indicating the parameter status appear to the left of the parameter reading. You can use these glyphs to quickly identify the status of a parameter (fail, locked, high- or low-system alarm, etc.) See Table 5.2—Parameter Status Glyph Definitions, page 81 for more information about the parameter status glyphs.

Table 5.1—Device Status Glyph Definitions





	<p>Keypad Use. This glyph depicts the four keys positioned on either side of the LCD. Pressing a key on the keypad causes the corresponding key in the glyph to appear filled, verifying that the key is actuated.</p>	
	<p>Device Boot-up Failure. The illumination of all four keys in the keypad glyph when no keys are depressed signals a boot failure. Should this occur, the LEP and UIC firmware versions will appear as “0.000” in the web interface (Device menu), and the communication ports and turbine inputs will not function properly.</p>	
	<p>To rule out a hardware failure:</p> <ol style="list-style-type: none"> 1. Remove all power sources and unplug power at the terminal block. 2. Let the device sit idle for at least 10 seconds. 3. Check the power supply to ensure it complies with the Scanner’s external power supply rating. 4. Restore power and check the keypad glyph. If the four quadrants are still illuminated, contact Sensia for assistance. 	
	<p>LCD Display Indicator (Center/Asleep). The default mode for the LCD display indicator.</p>	
	<p>LCD Display Indicator (Right). Cover the right half of the LCD display to stop auto-scrolling parameters and begin advancing parameters manually.</p>	
	<p>LCD Display Indicator (Left). Cover the left half of the LCD display to view the device name, firmware version, serial number, metrology hash codes, and the IP address.</p>	
	<p>External Power. An external power source has been detected.</p>	
	<p>Battery Status. These numbered glyphs represent the device’s two lithium battery packs. The left-most indicator represents the battery on the left as you face the display. Each glyph provides two indications.</p>	
	<p>Battery Capacity</p>	<p>The tall battery shape indicates battery capacity. A filled “battery pack” (black on a light gray background) indicates full capacity. An empty “battery pack” indicates a nearly depleted battery pack or none installed. Battery replacement is recommended when the indicator shows capacity to be 50% or less. Battery levels typically remain high (full) for the majority of a battery’s life and then deplete quickly near the end of the battery’s life.</p>
	<p>Battery State (In Use or Not in Use)</p>	<p>A filled block under the number indicates the battery is in use. One or both batteries may be in use at any given time. When external power is available, neither battery block should appear filled. If a mostly depleted battery is shown to be in use when you are ready to replace it, you may proceed without concern. The device will automatically switch to the remaining battery pack when one pack is disconnected from the device. To avoid interrupting operations: If both batteries are nearly depleted, connect an external power source before disconnecting the battery pack(s) for replacement. If external power is not available and at least one installed battery pack has the capacity to power the device momentarily, disconnect and replace the fully depleted pack before disconnecting and replacing the second pack.</p>

Table 5.1—Device Status Glyph Definitions



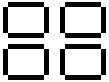
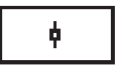



	<p>Wireless Communications Status.</p> <p>The wireless transmitter is disabled.</p> <p>No mesh nodes are configured.</p> <p>At least one mesh node is configured but none are operational.</p> <p>One or more mesh nodes are configured and at least one is operational.</p> <p>Multiple mesh nodes are configured and all are operational.</p>
---	--

Table 5.2—Parameter Status Glyph Definitions

	<p>Fail. This parameter value is in a fail state.</p>
	<p>High System Alarm. The parameter value exceeds the top end of the system operating range.</p>
	<p>Locked. The parameter is in Maintenance mode, or is configured to use a user-specified override value.</p>
	<p>Low System Alarm. The parameter value is below the low end of the system operating range (low end).</p>
	<p>High User-Configured Alarm. The parameter value exceeds the user-configured high setpoint.</p>
	<p>Low User-Configured Alarm. The parameter value is below the user-configured low setpoint.</p>

Configurable Display Features

A number of display features can be configured via the QRATE Scanner 3100 web interface with the proper user permissions.

Note	Only users with Administrator or Configuration Editor user access levels can change display features. See the QRATE Scanner 3100 Web Interface User Manual for instructions on setting user security levels.
------	--

- **Orientation.** By default, display orientation is set to “automatically detect” the orientation of the device. If the device is inverted, the display will automatically invert as well for optimum visibility. A user can also specify the orientation of the MVT port as upward or downward.
- **Color Scheme.** The LCD display background can be configured as light gray or dark gray. Character color automatically adjusts to provide contrast for easy viewing.
- **Message Delay.** This setting determines the length of time a set of parameters is displayed between scrolls. The default setting is 10 seconds. The configurable range of values is 0 to 600 seconds (10 minutes).

Message Display Mode

You can force selected “high priority” parameters to be displayed only in the top field of the display by assigning a priority status to these parameters (Figure 5.2).

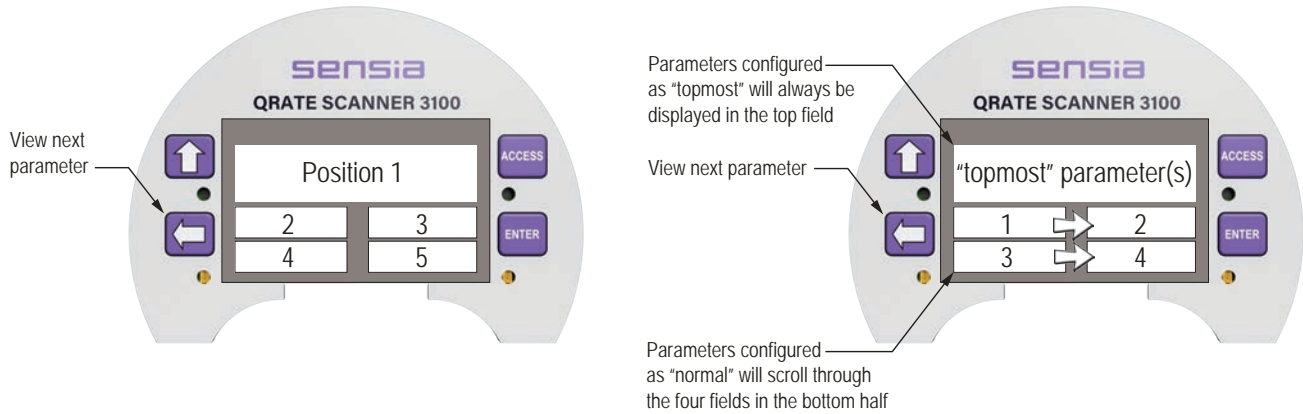

Figure 5.2—Arrangement of parameters in LCD display

Figure 5.2 shows the standard order of progression as parameters cycle through five display fields on the LCD. You may choose to restrict the large topmost display field for displaying high-priority parameters that require constant monitoring. When one or more parameters are configured as “topmost” priority in the web interface, the display effectively functions as two parallel scrolling sequences. The large “topmost” field will scroll the high priority parameters and the bottom four fields will scroll the other normal priority parameters. If only one parameter is configured as “topmost” priority, it will remain in constant view in the top display. For additional message display modes, refer to the QRATE Scanner 3100 Web Interface Manual.

Keypad Controls

Using the keypad buttons, a user can manually pace the QRATE Scanner 3100 display, locate its serial number and firmware version, and view communications settings. Table 5.3—Keyboard Controls identifies the button-press configurations for performing these tasks.

Table 5.3—Keyboard Controls

Keyboard Control	Action
Stop scrolling and advance parameters manually	Press LEFT ARROW or COVER RIGHT
View device name, firmware version, serial number, metrology hash codes, IP address	COVER LEFT
View serial port configuration settings (including protocol, baud rate, slave address, unit ID)	Press ACCESS

LCD Display Indicator

To change the LCD display view, leave the enclosure lid in place and cover the right side or left side of the LCD with your hand for 4 to 8 seconds, after which the device should detect your hand. Upon detection, the Scanner window will display a popup window with the device information.

Note	When covering the LCD display, there is no need to touch the LCD glass or to completely block your view of the LCD.
------	---

When the LCD Display Indicator changes position from the center to the left, the device name, firmware version, serial number, metrology hash codes, and IP address will appear. The metrology device and software codes are 32-bit values contained within the binary file loaded onto the QRATE Scanner 3100. The codes uniquely define the device firmware and software to ensure that the firmware has not been modified.

Cover the right side of the LCD to stop automatic scrolling and enable manual pacing through the device parameters.

Viewing Communication Settings

Press the ACCESS key to display the communication port settings, beginning with Serial Port 1 (Figure 5.3). The display will momentarily progress to the settings for the other serial port settings.

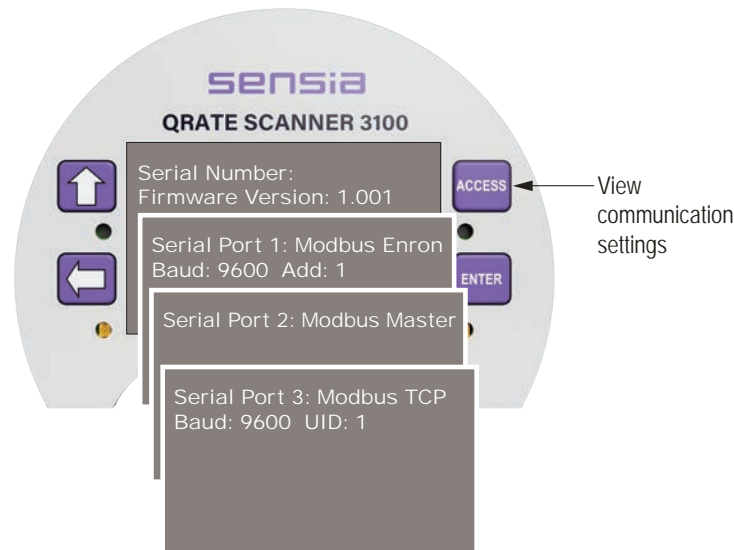

Figure 5.3—Communication parameters accessible via the Access key

This page intentionally left blank.

Section 6—QRATE Scanner 3100 Maintenance

The QRATE Scanner 3100 is engineered to provide years of dependable service with minimal maintenance. Batteries require periodic replacement, and battery life depends on (1) whether battery power is the primary or secondary power source, (2) the configuration settings of the device, and (3) ambient temperature conditions. All configuration settings are stored in nonvolatile memory; therefore, configuration settings will not be lost in the event of power failure.



WARNING

Before servicing the QRATE Scanner 3100, disconnect all power sources/signal sources or verify that the atmosphere is free of hazardous gases. Do not remove the cover while circuits are alive. The QRATE Scanner 3100 poses no hazard when opened in a safe area.

Lithium Battery Pack Replacement

Two integral battery packs provide backup power for the QRATE Scanner 3100 when external power is present, and can sustain the device for short periods as an autonomous power supply. Battery life can vary, depending on the power demands of the configuration. As an autonomous supply, the dual battery packs have an estimated life of 2 to 3 weeks, assuming the device is configured with a base load.

A battery capacity indicator in the device's display helps users predict the need for battery replacement. See [Table 5.1—Device Status Glyph Definitions, page 80](#), for details. Battery replacement is recommended when the indicator shows capacity to be 50% or less. Battery levels typically remain high (full) for the majority of a battery's life and then deplete quickly near the end of the battery's life. When two packs are installed, a user can replace a spent battery pack without interrupting operations.



WARNING

The lithium battery pack that powers the QRATE Scanner 3100 is a sealed unit; however, should a lithium battery develop a leak, toxic fumes could escape upon opening the enclosure. Ensure that the instrument is in a well-ventilated area before opening the enclosure to avoid breathing fumes trapped inside the enclosure. Exercise caution in handling and disposing of spent or damaged battery packs. See additional information in [Lithium Battery Disposal, page A-1](#).



CAUTION

Danger of explosion if battery is incorrectly replaced. Replace only with the same or equivalent type.

ATTENTION

Risque d'explosion si la pile n'est pas remplacé correctement. Remplacer uniquement par une pile de type identique ou équivalent.

Replacement Procedure

The stick-style battery packs are installed in a compartment just below the display ([Figure 6.1](#)). Battery leads are connected to the QRATE Scanner 3100 via two connectors extending from the back side of the display assembly on either side of the rounded cutout.

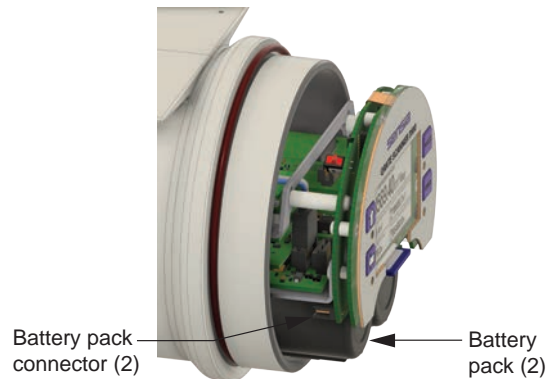

Figure 6.1—Removal of the battery pack from the enclosure

To replace the device's lithium battery pack,

1. Remove the cover from the enclosure (after securing the area per the warning on the previous page).

Note

When covering the LCD display, there is no need to touch the LCD glass or to completely block your view of the LCD.

2. Disconnect the battery leads of the spent battery from the connector on the back side of the display assembly.
3. Firmly grasp the battery pack and gently pull it forward to remove it from the enclosure.
4. Insert the fresh battery pack so that the battery lead end faces the rear of the battery compartment.
5. Connect the lead to the connector on the back side of the display assembly.
6. Repeat steps 2 through 5 to replace the other battery pack if required. Even if no external power is supplied, operations will continue uninterrupted as long as one battery pack remains connected.
7. Replace the enclosure cover.

Section 7—QRATE Scanner 3100 Parts

Spare Parts and Optional Hardware

The stick-style lithium battery packs, the lithium coin cell battery that controls the real-time clock, and the desiccant packets are the only consumable parts within the QRATE Scanner 3100 that require periodic replacement. If a WiFi communication accessory is in use, fuses may be replaced periodically as well.

Lithium coin cell batteries can last 8 years or longer, depending on operating conditions. Keeping a spare battery on hand can prevent the loss of the device time and date in the event the coin cell battery fails.



WARNING

EXPLOSION HAZARD: Substitution of components may impair suitability for Class I, Division 1. Use of spare parts other than those identified by Sensia International Corporation voids hazardous area certification. Sensia bears no legal responsibility for the performance of a product that has been serviced or repaired with parts that are not authorized by Sensia.



CAUTION

Danger of explosion if battery is incorrectly replaced. Replace only with the same or equivalent type.

ATTENTION

Risque d'explosion si la pile n'est pas remplacé correctement. Remplacer uniquement par une pile de type identique ou équivalent.

Table 7.1—QRATE Scanner 3100 integrated control flow computer Parts

Qty.	Part Number	Description
Common Parts		
1*	9A-100002605	Desiccant, Humidisorb, Self Regenerate, 2 in. x 2 in. Packet with Adhesive
1	3J-40-0245-00	Battery, BR 2032, 3 V, 190 mAh, Lithium Coin
1	76526610	Connector, Power, 2-pin, Connects to the Terminal Strip
2	76525511	O-Ring, 120 mm × 4 mm, XD-I, for Explosion-proof Enclosures
1	50268179	Kit, Pole Mount, Stainless Steel
For wireless components, see Table 7.2—Wireless Components, page 89 .		
CSA-Approved Parts		
1	9A-21-XX-YY (see Table 7.3—RTD and Cable Assemblies, page 90)	Assembly, RTD and Cable, CSA Explosion-Proof (Division 1), Model 21
1*	50261533	Battery Pack, 2 D Batteries in Series, 7.2 V, Lithium, Stick Style, CSA-approved
1	50267637	Assembly, External Explosion-proof Switch, with Extension, CSA-approved, Fits 3/4 in. Female Pipe Thread, Momentary Contact, Wired Ends (uses include manual control of flow accumulation, and manual control of a triggered archive)
1	50271475	Assembly, External Explosion-proof Switch, with Extension, CSA-approved, Fits 3/4 in. Female Pipe Thread, Momentary Contact, with Lockout Mechanism, Wired Ends (uses include manual control of flow accumulation or manual control of a triggered archive)
1	50267636	Assembly, External Explosion-proof Switch, with Extension, CSA-approved, Fits 3/4 in. Female Pipe Thread, Toggle, Wired Ends (uses include pacing the display, toggling a wireless transmitter on and off, resetting grand totals for flow run or pulse input accumulations, unlatching a digital output, and resetting a latch on a triggered archive)
1	50271474	Assembly, External Explosion-proof Switch, with Extension, CSA-approved Fits 3/4 in. Female Pipe Thread, Toggle, with Lockout Mechanism, Wired Ends (uses include pacing the display, toggling a wireless transmitter on and off, resetting grand totals for flow run or pulse input accumulations, unlatching a digital output, and resetting a latch on a triggered archive)

Table 7.1—QRATE Scanner 3100 integrated control flow computer Parts

<i>Qty.</i>	<i>Part Number</i>	<i>Description</i>
ATEX-Approved Parts		
1	9A-X-TTXR-0003	Assembly, RTD and Cable, Flameproof, 3500-mm Cable, 50-mm Probe, ATEX-approved, for Line Sizes from 2 to 12 inches
1	50302004	Battery Pack, 2 D Batteries in Series, 7.2 V, Lithium, Stick Style, ATEX-approved
1	50302001	Assembly, External Explosion-proof Switch, with Extension, ATEX-approved, Fits 3/4 in. Female Pipe Thread, Momentary Contact, Wired Ends (uses include manual control of flow accumulation, and manual control of a triggered archive)
1	50302003	Assembly, External Explosion-proof Switch, with Extension, ATEX-approved, Fits 3/4 in. Female Pipe Thread, Momentary Contact, with Lockout Mechanism, Wired Ends (uses include manual control of flow accumulation or manual control of a triggered archive)
1	50301998	Assembly, External Explosion-proof Switch, with Extension, ATEX-approved, Fits 3/4 in. Female Pipe Thread, Toggle, Wired Ends (uses include pacing the display, toggling a wireless transmitter on and off, resetting grand totals for flow run or pulse input accumulations, unlatching a digital output, and resetting a latch on a triggered archive)
1	50302000	Assembly, External Explosion-proof Switch, with Extension, ATEX-approved Fits 3/4 in. Female Pipe Thread, Toggle, with Lockout Mechanism, Wired Ends (uses include pacing the display, toggling a wireless transmitter on and off, resetting grand totals for flow run or pulse input accumulations, unlatching a digital output, and resetting a latch on a triggered archive)

* *Recommended spare part*

** *For router adapters with other voltage ratings, contact Sensia.*

Table 7.2—Wireless Components

Qty.	Part No.	Description
1	77012876	Antenna Coupler, N Coax, Male-to-Male (Female Thread), CSA & ATEX-approved
1	2350869-01	Antenna, Short-haul Wireless, 2.4 GHz, 1/2 Wave Dipole, N Male, Right-Angle
1	50279275	Antenna, Short-Haul Wireless, Remote-Mount, 9 dBi 2.4 GHz Omnidirectional, 32-in. long, N Female with pole-mount bracket (fits pole outside diameters up to 2-in.)
1	50278052	Bracket, Pipe-Mount for Remote-Mount Antenna (fits pipe with 2.375-in. outside diameter)
1	77012875	Cable, Antenna, 12-in long, Straight
1	76527410	Antenna Cable with Connectors, Short-haul Wireless, 10-ft, Type 400, -40 °C to 70 °C (-40 °F to 158 °F)
1	76527411	Antenna Cable with Connectors, Short-haul Wireless, 20-ft, Type 400, -40 °C to 70 °C (-40 °F to 158 °F)
1	76527412	Antenna Cable with Connectors, Short-haul Wireless, 30-ft, Type 400, -40 °C to 70 °C (-40 °F to 158 °F)
1	50272454	Ethernet Router, Portable, USB-powered; 110 V/220 V-to-USB Adapter Included (not required when PC-powered with USB cable)**
1	76528845	Ethernet Router, Portable, Integral Rechargeable Lithium-Ion Battery-powered
1	76528309	RJ-45 Ethernet Cable, 15-ft Molded Connector
1	50272960-05	Cable, Ethernet, 5 ft, for WiFi Communications Accessory for Multi-Scanner Sites
1	50272960-10	Cable, Ethernet, 10 ft, for WiFi Communications Accessory for Multi-Scanner Sites
1	50272960-20	Cable, Ethernet, 20 ft, for WiFi Communications Accessory for Multi-Scanner Sites
1	50272960-30	Cable, Ethernet, 30 ft, for WiFi Communications Accessory for Multi-Scanner Sites
2*	9A-0111-9007T	Fuse, 5 amp, 5 × 20, Glass, for WiFi Communications Accessory for Multi-Scanner Sites
2	9A-0142-9003T	Assembly, Clamp and U-Bolt, 2-1/2 in., for WiFi Communications Accessory for Multi-Scanner Sites

* Recommended spare part if WiFi Communications Accessory is in use

Table 7.3—RTD and Cable Assemblies

Select assemblies based on specific application.

Cable length and probe length are specified in the part number:

9A-21-XX-YY where XX is the cable length and YY is the probe length.

Available cable lengths: 5, 10, or 30 ft. Probe nominally adjustable up to 6 in. or 12 in.

Qty.	Part No.	Description
1	9A-21-05-06	Model 21 RTD, CSA Explosion-proof, 5-ft Cable, 7.625-in. Probe for 6-in. Thermowell
1	9A-21-05-12	Model 21 RTD, CSA Explosion-proof 5-ft Cable, 11.625-in. Probe for 12-in. Thermowell
1	9A-21-10-06	Model 21 RTD, CSA Explosion-proof 10-ft Cable, 7.625-in. Probe for 6-in. Thermowell
1	9A-21-10-12	Model 21 RTD, CSA Explosion-proof 10-ft Cable, 11.625-in. Probe for 12-in. Thermowell
1	9A-21-30-06	Model 21 RTD, CSA Explosion-proof 30-ft Cable, 7.625-in. Probe for 6-in. Thermowell
1	9A-21-30-12	Model 21 RTD, CSA Explosion-proof 30-ft Cable, 11.625-in. Probe for 12-in. Thermowell

The thermowell dimensions listed above refer to the maximum “U” dimensions that a probe will fit with a plastic bushing. Consult Sensia for sizing information if a union and nipple is to be used in place of a bushing. When using a bushing, select the shortest probe possible for a compact installation and best strength.

Electronics Replacement

The QRATE Scanner 3100 contains two circuit board subassemblies (pre-assembled groupings of circuit boards and hardware), a terminal board, and an optional advanced communications board (for support of wireless communications) that can be replaced by a knowledgeable technician. For disassembly instructions, see the QRATE Scanner 3100 Service User Manual. Subassemblies must be replaced without further disassembly. Before attempting any repair work on the device, contact a Sensia technician to review the issues you are observing and determine if the problem requires hardware replacement.

CAUTION	EQUIPMENT DAMAGE RISK: Attempts to disassemble the QRATE Scanner 3100 in the field for the purpose of troubleshooting or repairs can damage the internals and cables beyond repair. Sensia does not warranty damage resulting from field replacement of QRATE Scanner 3100 parts.
---------	---

Table 7.4—QRATE Scanner 3100 Circuit Board Replacements

Qty.	Part Number	Description
1	50279707	Display Subassembly, includes Hardware Kit and Coin Cell Battery
1	50279704	Main Subassembly, includes Hardware Kit and SATA Cable (Field replacement in devices equipped with an MVT can result in accuracy degradation.)
1	2350508-01	Terminal Board
1	50279738	Advanced Communications Board, CSA
1	50331936	Advanced Communications Board, ATEX (does not support WiFi Board, obsolete, replaced by 5030462ROHS and 50300464ROHS)
1	50300462ROHS	Advanced Communications Board, ATEX (supports WiFi Board)
1	50300464ROHS	Smartmesh Circuit Board Assembly
1	50327132	WiFi Circuit Board Assembly
1	77012874	Cable, SATA, 200mm, Straight with Latch (For use with WiFi Board)
1	76522730	Cable, SATA, 300 mm, Straight with Latch
1	50279708	Hardware Kit (includes screws and standoffs for subassemblies)

Appendix A—Lithium Battery Information

Lithium Battery Disposal

Once a lithium battery is removed from a device and/or is destined for disposal, it is classified as solid waste under EPA guidelines. Depleted lithium batteries are also considered to be hazardous waste because they meet the definition of Reactivity, as per 40 CFR 261.23(a)(2), (3) and (5). This document describes how the lithium reacts violently with water, forms potentially explosive mixtures with water, and when exposed to certain pH conditions, generates toxic cyanide or sulfide gases.

Federal law requires that depleted lithium battery packs be sent to a fully permitted Treatment, Storage and Disposal Facility (TSDF) or to a permitted recycling/reclamation facility.

IMPORTANT	Do not ship lithium battery packs to our factory. Sensia facilities are not permitted recycling/reclamation facilities.
CAUTION	Profiling and waste characterization procedures must be followed prior to shipping a lithium battery to a disposal site. It is the shipper's responsibility to comply with all applicable federal transportation regulations (see below).

Transportation Information



WARNING

The QRATE Scanner 3100 contains lithium batteries. The internal component (thionyl chloride) is hazardous under the criteria of the Federal OSHA Hazard Communication Standard 29 CFR 1920.1200. Before shipping a lithium battery or equipment containing a lithium battery, verify that the packaging and labeling conforms with the latest version of all applicable regulations.

The transport of the lithium batteries is regulated by the United Nations, "Model Regulations on Transport of Dangerous Goods," (special provisions 188, 230, and 310), latest revision.

Within the United States, the lithium batteries and cells are subject to shipping requirements under Part 49 of the Code of Federal Regulations (49 CFR, Parts 171, 172, 173, and 175) of the US Hazardous Materials Regulations (HMR), latest revision.

Shipping of lithium batteries in aircraft is regulated by the International Civil Aviation Organization (ICAO) and the International Air Transport Association (IATA) requirements in Special Provisions A45, A88 and A99, latest revision.

Shipping of lithium batteries on sea is regulated the International Maritime Dangerous Goods (IMDG) requirements in special provisions 188, 230 and 310, latest revision.

Shipping of lithium batteries on road and rail is regulated by requirements in special provisions 188, 230 and 310, latest revision.

Battery Safety Datasheet

For a link to the current MSDS for the lithium batteries used to power the QRATE Scanner 3100, see <https://sensiaglobal.com/Measurement>.

This page intentionally left blank.

Appendix B—FTP Downloads

FTP downloads provide an alternative to the web interface download process and may be preferred for expediting downloads, particularly if you have no other need to log into the web interface. FTP downloads can be performed with a router connection to the Scanner, or with a physical Ethernet cable connection between the PC/laptop and the Scanner. The only piece of information required is the IP address of the QRATE Scanner 3100 storing the archive files.

The following steps describe the FTP download process using the Windows FTP Command executable file.

IMPORTANT	Other third-party FTP file managers, such as File Commander, provide a graphical interface. Please note that the QRATE Scanner 3100 currently supports only one FTP session at a time; some software programs require two simultaneous sessions to function properly.
------------------	---

Downloading SDF Files from the QRATE Scanner 3100

To download SDF files using Windows FTP Command prompts, perform the following steps:

1. Access the *Command Prompt* window by clicking the **Start** button.
2. Type `cmd` and click **Enter**.
3. Type `ftp <IP address of the QRATE Scanner 3100 device>` and click **Enter**.
4. At the prompt, type `<your login name>` and click **Enter**.
5. At the prompt, type `<your login password>` and click **Enter**.
6. Type `cd archives` and click **Enter** to access the parent level of the directory. This directory contains three folders of SDF files: full, recent, and events.
7. Type `cd <file type>` (for example, `cd full` to select the full folder) and click **Enter**.
8. Type `ls` or `dir` to view a list of .sdf files inside the folder. The command “dir” provides additional details about the files such as archive timestamp and file size.
9. To download an .sdf file, type `get <complete filename> c:<location for saving the SDF file>` and click **Enter**.
10. To download a batch of .sdf files, type `bye` to exit the connection. The command prompt will display your default directory. Unlike the single file download process where you can specify the desired location of the download files as part of the command string, batch downloads require you to establish the intended location before the download command is issued.
11. If the current directory is not where the SDF files are to be stored, type `cd <desired directory path for storing SDF files>` and click **Enter**.
12. Type `cd archives\<file type>` (for example, `cd archives\full`) and click **Enter**.
13. Type `prompt` and click **Enter**.
14. Type `mget <*.sdf>` and click **Enter**. The batch of files should automatically be transferred to the directory path designated in step 11.

Note	FTP clients are prone to timeouts. To restart following a timeout, type <code>open <Scanner IP address></code> .
Note	To move back one level in your directory path, type <code>cd ..</code>

Full Folder Contents	Example Filename
Daily Logs: QRATE Scanner 3100	S3100_FA01_D_Full.sdf
Interval Logs: QRATE Scanner 3100	S3100_FA01_I_Full.sdf
Triggered Logs: QRATE Scanner 3100	DeviceName_TR_Full.sdf
Daily Logs: NUFLO Scanner 2000 series flow computers configured as a slave device (up to 20 logs possible)	Slave01_SA01_D_Full.sdf
Interval Logs: NUFLO Scanner 2000 series flow computers configured as a slave device (up to 20 logs possible)	Slave01_SA01_I_Full.sdf
Local (All archive logs only, includes no logs for networked slave devices)	S3100_Local.sdf
Complete (Complete archive record and networked slave devices)	S3100_Complete.sdf
Event Logs: QRATE Scanner 3100	S3100_EA_Full.sdf
Event Logs: NUFLO Scanner 2000 series flow computers configured as a slave device	Slave01_SE01_Full.sdf
File Name Conventions	
QRATE Scanner 3100 Daily or Interval Logs	Example: S3100_FA01_D_Full.sdf , where FA01 = flow archive (FA01 or FA02) and D = type of log (D for daily or I for interval)
Slave Device Daily or Interval Logs	Example: Slave01_SA01_D_Full.sdf , where Slave 01 = slave ID (up to 20 possible), SA01 = slave archive (one for each slave device) and D = type of log (D for daily or I for interval)
QRATE Scanner 3100 Event Archive	Example: S3100_EA_Full.sdf , where EA = Event Archive
Slave Device Event Archive	Slave01_SE01_Full.sdf , where SE01 = slave archive (one for each slave device) and EA = Event Archive
QRATE Scanner 3100 Recent Logs (interval logs recorded within current 24-hour contract period)	S3100_FA01_I_20140823.sdf , where FA01 = flow archive (FA01 or FA02), I = type of log (D for daily or I for interval) and 20140823 = date stamp (year-month-day)

Slave Device Archive Logs

Slave archive logs can also be downloaded locally from a NUFLO Scanner 2000, 2105 or 2200 using Mod-WorX™ Pro software.

Viewing and Sharing Downloaded Data

Sensia's Scanner Data Manager software opens the proprietary SDF files and provides an assortment of file sharing, conversion and reporting tools. See the Scanner Data Manager manual for more information. To download software or user documentation, visit sensiaglobal.com/Measurement. Scroll to select **FLOW COMPUTING AND AUTOMATION**, then click **QRATE SCANNER 3000 SERIES INTEGRATED CONTROL FLOW COMPUTERS** and click the link for the desired software installation or user manual.

Appendix C—Firmware, Configuration, Scanner Logic, and Modbus Register Map Uploads

Firmware Uploads

The factory default firmware is easily restored using the QRATE Scanner 3100 web interface. Simply log into the device interface, select **ADMINISTRATION>GENERAL** from the taskbar, then click **Management** at the left of the screen. Under the “Firmware Management” section near the bottom of the screen, click **Restore Firmware**.

To upload new firmware, download the ScanFlash software utility and follow the upload instructions listed under [ScanFlash Upload, page C-2](#).

IMPORTANT

To download software or user documentation, visit sensiaglobal.com/Measurement. Scroll to select **FLOW COMPUTING AND AUTOMATION**, then click **QRATE SCANNER 3000 SERIES INTEGRATED CONTROL FLOW COMPUTERS** and click the link for the desired software installation or user manual.

Configuration Uploads

A user can load factory-set default configuration values, save the current configuration file, and upload an existing configuration file using the QRATE Scanner 3100 web interface. A configuration file can also be uploaded using ScanFlash software utility.

- To make configuration changes from the web interface, select **ADMINISTRATION>GENERAL** from the taskbar, then click **Management** at the left of the screen. Locate the “Configuration Management” section at the top of the screen.
 - To load default configuration values, click **Load Configuration Defaults** and click **OK** at the *Confirm* dialog prompt.
 - To save currently applied configuration values in a file that can be later uploaded to a device, right-click the **QRATE SCANNER 3100 CONFIGURATION FILE** link, then click **Save link as...** Rename the file and/or change the location where the file will be stored, if desired.
 - To upload a configuration file that was previously saved to your computer, click **Browse** next to “Load Configuration File,” select the desired configuration file to upload, and click **Open**. From the interface screen, click **Submit**, click **OK** at the *Confirm* dialog, and wait for the file to upload.
- To upload a configuration file using ScanFlash, download the ScanFlash software utility and follow the upload instructions listed under [ScanFlash Upload, page C-2](#).

IMPORTANT

To download software or user documentation, visit sensiaglobal.com/Measurement. Scroll to select **FLOW COMPUTING AND AUTOMATION**, then click **QRATE SCANNER 3000 SERIES INTEGRATED CONTROL FLOW COMPUTERS** and click the link for the desired software installation or user manual.

Register Map Uploads

Using Sensia’s ScanMap software, a user can create a set of user-defined Modbus register maps (.pmap) for customizing Modbus communications protocols. A .pmap file can be uploaded to a QRATE Scanner 3100 using the device web interface or the ScanFlash software utility. Files are uploaded to the web interface by selecting **Administration>General>Installed Files**.

IMPORTANT

To download software or user documentation, visit sensiaglobal.com/Measurement. Scroll to select **FLOW COMPUTING AND AUTOMATION**, then click **QRATE SCANNER 3000 SERIES INTEGRATED CONTROL FLOW COMPUTERS** and click the link for the desired software installation or user manual.

- To upload a register map via the web interface, log into the device interface, select **ADMINISTRATION > GENERAL** from the taskbar and click **Installed Files** at the left of the screen. To erase the map currently installed, click **Uninstall PMAP File** and click **OK** at the *Confirm* prompt. Then, click **Browse** under “Install Protocol Map File,” select the desired configuration (.pmap) file to upload, and click **Open**. From the interface screen, click **Submit**, click **OK** at the *Confirm* dialog, and wait for the file to upload.
- To upload a register map file via the ScanFlash utility, follow the upload instructions under [ScanFlash Upload, page C-2](#).

ScanFlash Upload

IMPORTANT	To download software or user documentation, visit sensiaglobal.com/Measurement . Scroll to select FLOW COMPUTING AND AUTOMATION , then click QRATE SCANNER 3000 SERIES INTEGRATED CONTROL FLOW COMPUTERS and click the link for the desired software installation or user manual.
IMPORTANT	To upload firmware to the QRATE Scanner 3100, you must have Administrator-level user access. To upload configuration files or custom Modbus register maps, you must have Configuration Editor-level or Administrator-level user access.

1. Download ScanFlash from the Sensia website, as noted above.
2. Open a web browser and enter the IP address of the device to establish a connection to the device.
3. Download all historical data from the device.
4. Open ScanFlash (shown in [Figure C.1](#)) and enter the IP address for the device.
5. Close the browser and clear the browser cache.
6. Select the firmware (BIN), configuration (SCF), Scanner Logic (SLBIN), or Modbus map (PMAP) file to be uploaded.

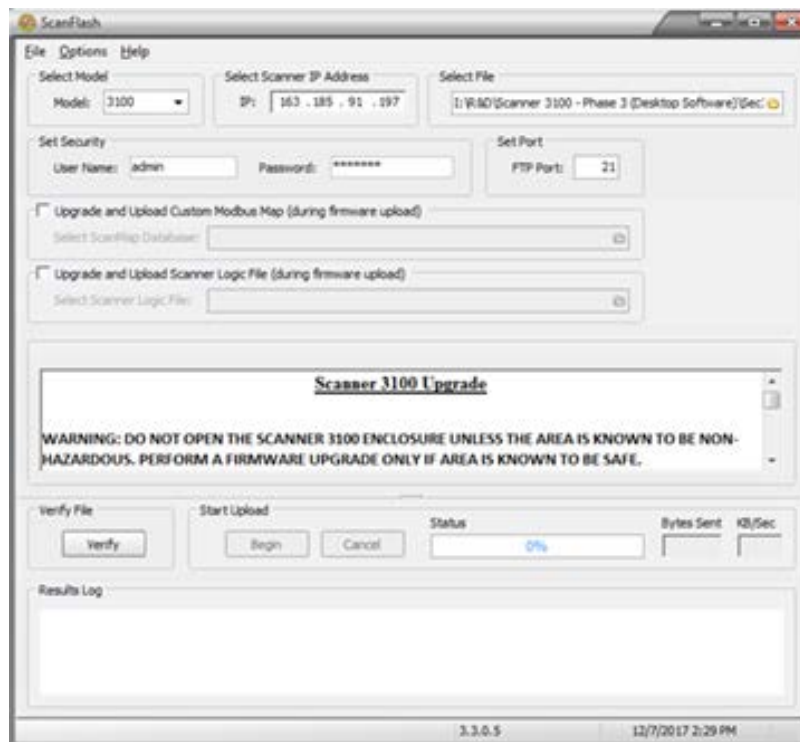

Figure C.1—ScanFlash interface

7. Enter your user name and password for accessing the device web interface. You must have the appropriate user access level to proceed. See the “Important” note above.

8. Click **Verify** to confirm the connection and identify the current firmware version. The button will turn blue while the utility attempts to communicate with the Scanner.
 - When a connection has been verified, the Scanner’s system information will appear in the Results log at the bottom of the screen.
 - If a connection cannot be made, an error message will appear. Check the IP address, username and password and click “Verify” again.
9. Click **Begin** to begin the file upload to the device.
10. Monitor the Status bar for percentage of upload completion. The process should take 3 to 4 minutes for firmware files and less than a minute for configuration and Modbus map files.

When the firmware or configuration upload is completed, ScanFlash will automatically disconnect from the device. The Results log at the bottom of the screen will display “Successfully Flashed Scanner” and the utility will try to reconnect to the device to retrieve the version information. The Results log will display the updated version information if the new firmware is loaded and the reconnection is successful.

Note	Verification may fail if the IP address has changed, as is typical with dynamic IP addresses. If the verification fails, check the upper left corner of the device display, enter the IP address displayed on the device, click Verify and confirm that the correct firmware is loaded. If desired, reset the device IP address after verification. For more information, consult the QRATE Scanner 3100 Web Interface User Manual.
------	---

11. Open the web browser and login to the device’s web interface.
12. Verify the date and time in the QRATE Scanner 3100 *Device Status* screen. If it is not correct, click on the *Administration* tab and click **Device Time** to update the date and time.

Troubleshooting a Failed Upload

If the upload does not complete as expected, communications may have been lost during the upload or the file you are attempting to upload (configuration or Modbus map) may have been created for use with a different version of firmware than that installed on the device.

If there is no apparent firmware version conflict, perform the following steps:

1. Click **Cancel** to abort the upload.
2. Remove power from the device.
3. Restore power to the device.
4. Restart ScanFlash and repeat the upload process.

This page intentionally left blank.

Appendix D—Measurement Canada Configuration

It is imperative that the device be installed as per the guidelines that have been articulated by Measurement Canada. Any explicit instructions or guidelines from Measurement Canada take precedence over the instructions given in this manual.

Measurement Canada has approved with firmware versions within the range of 3.040 to 3.069. Ensure that the firmware installed is within this range before proceeding with the installation.

For Measurement Canada, it is necessary to lock the configuration so that there cannot be any changes made, and the lids sealed such that tampering will be physically visible. For the QRATE Scanner 3100 there is a physical configuration lock switch that may be engaged (set toward the front of the Scanner) which will lock the configuration, and then the user may use the web interface to set the Scanner to the correct configuration locking mode. The configuration locking modes are as follows:

- **Secured Configuration (Category 3)** - If the Physical Configuration Lock is engaged (set toward the front of the Scanner), then configuration changes are only allowed as long as there is available capacity in the User Event Log. That is, while at least 1000 unused user event records remain (out of a total of 81,920 user event records). Verification Triggering Events are enabled.
- **Configuration Seal (Category 2)** - If the Physical Configuration Lock is engaged (set toward the front of the Scanner), then no configuration changes are allowed.

For Measurement Canada, set the configuration locking mode to Secured Configuration (Category 3). This will ensure that a Verification Triggering Event will occur if there is a change to a legally relevant metrological parameter, and will only allow configuration changes while there are at least 1000 unused user event records available.

Physical Configuration Lock Switch

The Physical Configuration Lock switch is located inside the QRATE Scanner 3100 housing along the top edge of the display circuit board assembly, just left of center (Figure D.1). The switch can be engaged (set toward the front of the Scanner) to prevent unauthorized individuals from changing the configuration of the device.

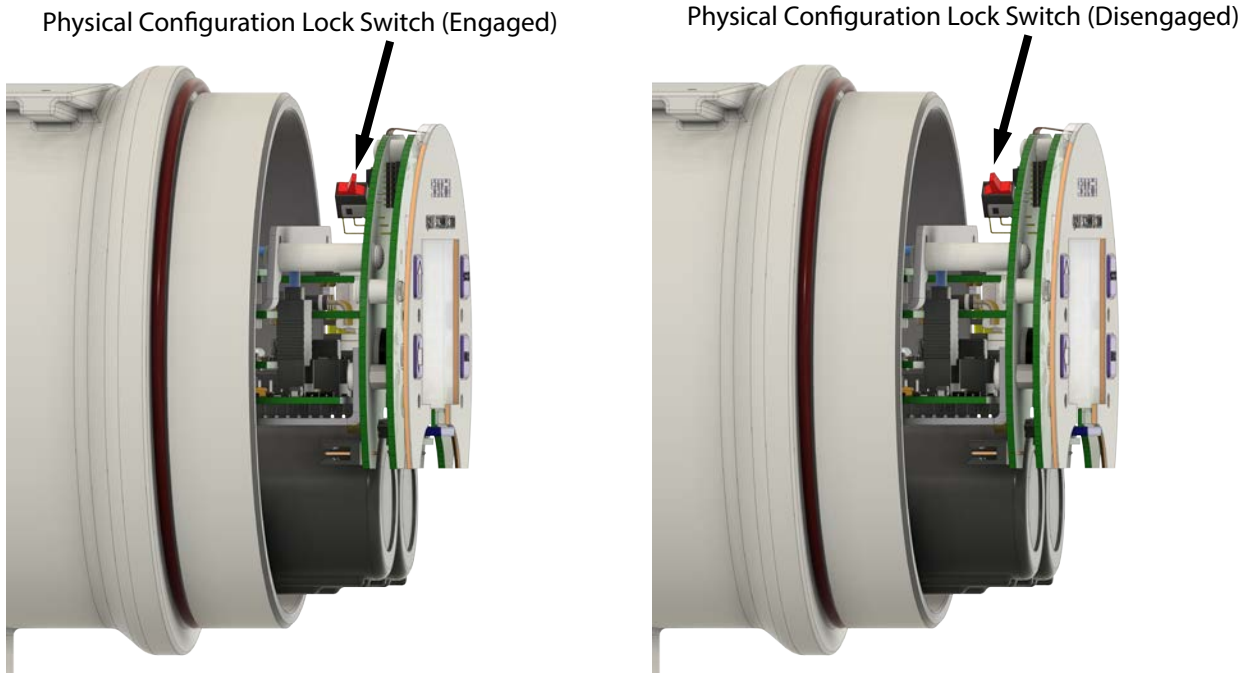

Figure D.1—Physical Configuration Lock switch

The position of the Physical Configuration Lock switch may be verified (i.e. that the switch has been fully engaged) by observing the LCD display. When the switch has been fully engaged a Lock Glyph will be displayed and the device will be secured. When the switch is disengaged, no lock glyph will appear, and the device will be unsecured.

In the Secured Configuration (Category 3) configuration the Lock Glyph will be “open” when configuration changes are still permitted, and the Lock Glyph will “close” when configuration changes are no longer permitted. In the Configuration Seal (Category 2) configuration the Lock Glyph will always remain “closed”, as configuration changes are never permitted in this mode.

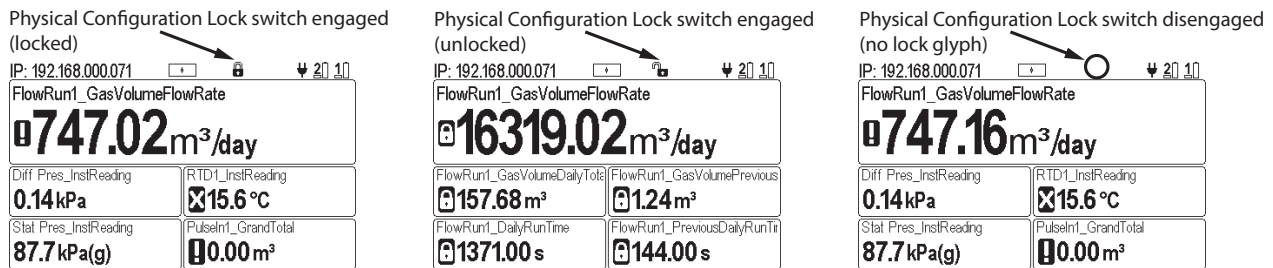

Figure D.2—The presence of the Lock Glyph indicates that the Physical Configuration Lock switch is engaged, and position (locked or unlocked) indicates if configuration changes are locked

To access the software Configuration Lock Mode settings use the following steps:

1. Navigate to the **ADMINISTRATION** menu by **DEVICE>ADMINISTRATION>GENERAL** (see Figure D.3).



Figure D.3—QRATE Scanner 3100 Web Interface directions to Device Status screen

2. The **ADMINISTRATION** menu will appear. Click **SECURITY** to navigate to the **SECURITY CONFIGURATION** menu (see Figure D.4).



Figure D.4—QRATE Scanner 3100 Web Interface Administration menu

- 3. The **SECURITY** menu will appear. Click button **MODIFY** and then click button beside Configuration Lock Mode (see Figure D.5).



Figure D.5—QRATE Scanner 3100 Web Interface Security menu

- 4. The Configuration Lock Mode will appear (see Figure D.6).

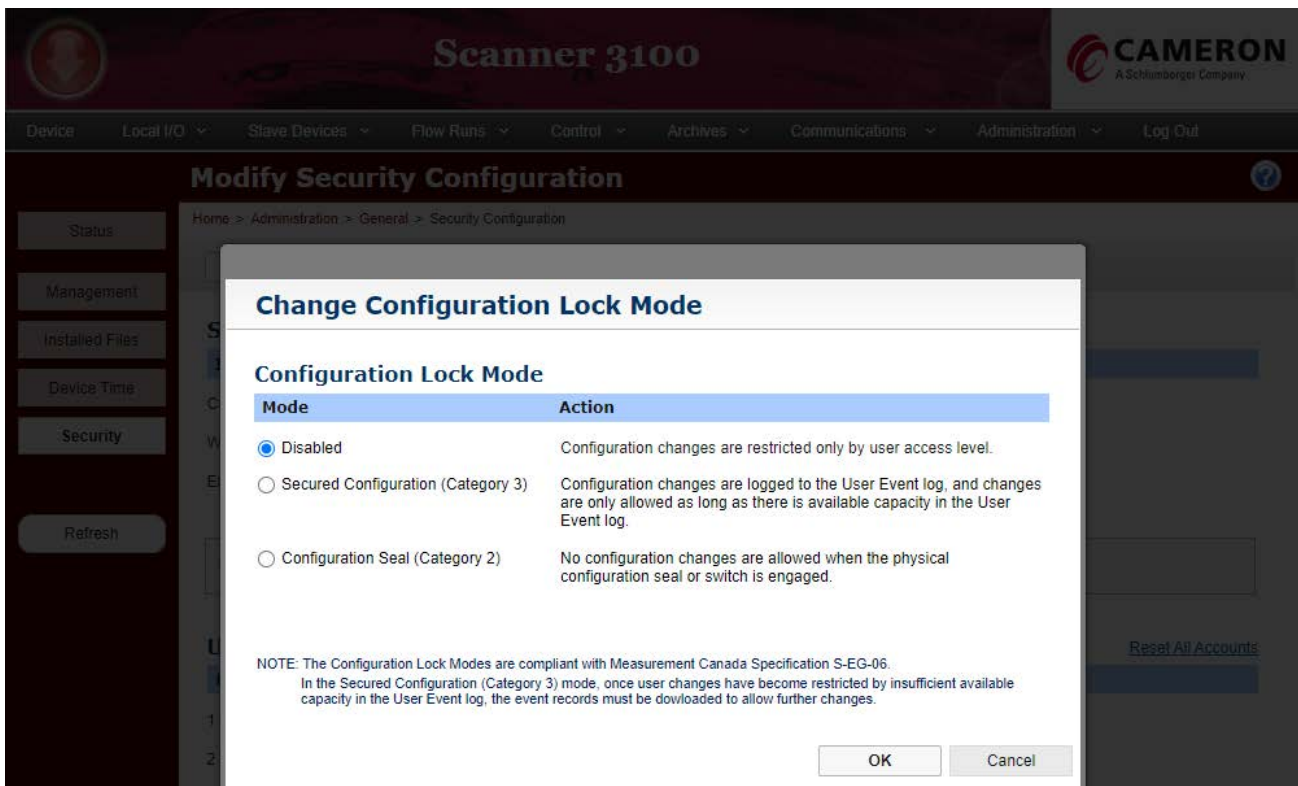





Figure D.6—QRATE Scanner 3100 Web Interface Configuration Lock Mode

For Measurement Canada, the Scanner must have firmware version: 3.040 - 3.069

	Configuration Seal (MC Category 2)	Secured Configuration (MC Category 3)
Physical Configuration Lock Disengaged	No Lock Glyph. Configuration changes are permitted.	No Lock Glyph Configuration changes are permitted.
Physical Configuration Lock Engaged	No configuration changes are permitted. 	More than 1000 unused or previously exported User Event records, and configuration changes are permitted. 
		1000 or less unused or previously exported User Event records, and no configuration changes are permitted. 

Note

For Secured Configuration (MC Category 3):

Verification Triggering Events (VTEs) are enabled, and will show on the LCD if there is a change to a legally relevant metrological parameter.

User changes will be restricted when the User Event log becomes nearly full, and the event records must be downloaded to allow further changes.

It is not possible to freely erase User Event change log records. Log records may only be overwritten after a user with sufficient permissions exports the log to an external memory, including date and time of intervention.

This is compliant with Measurement Canada Specification S-EG-06.

Device Physical Sealing Methods

After the configuration has been completed and the configuration lock switch has been engaged (set toward the front of the Scanner), then the lid may be replaced, and a seal is to be applied. For Measurement Canada, the sealing method is to install a wire seal. The wire must be connected through the hole provided on each lid (front and back lids) located below the set screws, and then tightly sealed with a lead seal.



Figure D.7—Seal applied to QRATE Scanner 3100 without requirement for removable batteries

Exporting User Event Records

When the device is sealed with Secured Configuration (Category 3) mode, the user can continue to make changes via the Web Interface or Modbus Protocols if less than 1000 records unused or previously exported records remain. To free up room, the user must be exported to an external memory. The User Change Records may only be overwritten after a user with sufficient privileges exports the log to an external memory, including date and time of intervention.

Note	Regular archive data downloads and Modbus downloads will not mark User Change Records as exported. Additional user changes are prevented once only 1000 unused or previously exported user event records remain.
Note	It is not possible to freely erase User Change Records.

To export the User Change Records and unlock the device for additional configuration changes, navigate to **ARCHIVES>EVENT ARCHIVE** and then select the Change Log Export tab.

The screenshot shows the 'Scanner 3100' web interface. The top navigation bar includes: Device, Local I/O, Slave Devices, Flow Runs, Control, Archives, Communications, Administration, and Log Out. The main content area is titled 'User Change Log Export' and contains the following sections:

- Status:** The device configuration is Secured according to Measurement Canada Specification S-EG-06 (Category 3). [Go to Event Archives Download](#)
- Measurement Canada Compliance:**
 - Item:** The Scanner 3100 complies with Measurement Canada Specification S-EG-06 (Category 3) for configurable metering devices having an exportable event log. This specification requires that:
 - All configuration changes to Legally Relevant Parameters (those parameters which are subject to verification under the Electricity and Gas Inspection Act) are to be recorded in a user change log.
 - When the user change log is nearly full, further configuration changes are prevented until the log has been exported by a user with sufficient security permissions.
- User Change Log Information:**

Item	Value
Unused Log Records Remaining	80920
Last Time of Export	2017/8/23 13:37:05
Last Record Identifier Exported	26621
Current Record Identifier	26621
- User Change Log Data File:** *Right-click file name and select Save As... to download data file.*

Description	File Name	File Size	File Date
User Change Log Records	S3100_EA_LegallyRelevant.sdf	4390370 bytes	2017/8/23 13:21:00

Footer: Copyright © 2011-7, Cameron. All rights reserved. Ready File ix. build 759 Logged in as: admin

Figure D.8—User Change Log Export on Web Interface

Verification Triggering Events

While in Secured Configuration (Category 3) mode, the QRATE Scanner 3100 can be remotely and locally configured without breaking a physical seal. Configuration capability of the QRATE Scanner 3100 is controlled by the Physical Configuration Lock switch and a software switch. Secured Configuration (Category 3) mode is compliant with Measurement Canada Specification S-EG-06. If a change occurs on a configuration parameter that triggers a Verification Triggering Event (VTE) then the Lock Glyph is not altered and still indicates if the configuration lock is enabled, as well as if the event log has remaining free capacity. However, the top display section of the LCD is over-riden with the message shown in Figure D.9 to clearly indicate the seal is not intact.



Figure D.9—Software Seal broken due to VTE (Verification Triggering Event)

While the Device Configuration is in Secured Configuration (Category 3) mode and the device configuration securing feature is initially enabled, the seal will be intact as shown in Figure D.10. It will remain so unless writing to configuration parameter causes a Verification Triggering Event (VTE). The only method to restore the sealed state is to disable the Configuration Lock mode and re-enable it.



Figure D.10—Software Seal intact on Web Interface

Removing Verification Triggering Event

In order to remove the Verification Triggering Event (VTE) follow these steps:

1. Break QRATE Scanner 3100 physical seal securing the front lid and remove the front lid.
2. Disengage the Physical Configuration Lock switch by pushing it away from the front of the Scanner.
3. Wait until display removes the VTE message and the Lock Glyph is not drawn.
4. Engage the Physical Configuration Lock switch by pulling it toward the front of the Scanner.

Note

When the physical seal is removed, then it is important to be aware that if the device was previously Measurement Canada certified, then the device will need to be re-certified.

WARRANTY - LIMITATION OF LIABILITY: Seller warrants only title to the products, software, supplies and materials and that, except as to software, the same are free from defects in workmanship and materials for a period of one (1) year from the date of delivery. Seller does not warranty that software is free from error or that software will run in an uninterrupted fashion. Seller provides all software "as is". THERE ARE NO WARRANTIES, EXPRESS OR IMPLIED, OF MERCHANTABILITY, FITNESS OR OTHERWISE WHICH EXTEND BEYOND THOSE STATED IN THE IMMEDIATELY PRECEDING SENTENCE. Seller's liability and Buyer's exclusive remedy in any case of action (whether in contract, tort, breach of warranty or otherwise) arising out of the sale or use of any products, software, supplies, or materials is expressly limited to the replacement of such products, software, supplies, or materials on their return to Seller or, at Seller's option, to the allowance to the customer of credit for the cost of such items. In no event shall Seller be liable for special, incidental, indirect, punitive or consequential damages. Seller does not warrant in any way products, software, supplies and materials not manufactured by Seller, and such will be sold only with the warranties that are given by the manufacturer thereof. Seller will pass only through to its purchaser of such items the warranty granted to it by the manufacturer.

CONTACT US

Regional Offices	Telephone
Alberta, Canada	+1 587 291 2190
Duncan, OK	+1 580 736 7600
Coraopolis, PA	+1 724 218 7800
Midland, TX	+1 432 247 6020
Tunbridge Wells, UK	+44 1892 518000
Mexico	+1 52 55 5246 2000

Toll-Free Support

1-866-7 SENSIA (+1 866 773 6742)

Inquiries
Service

measurement@sensiaglobal.com
ms-service@sensiaglobal.com

MANUFACTURING FACILITIES	SALES OFFICES	SALES OFFICES
Sensia UK Limited Longfield Rd, Tunbridge Wells, UK TN2 3EY	Sensia Limited 709 64th Ave SE 103, Calgary, AB T2H 2C3 CANADA	Sensia Oil & Gas Technical Development (Shanghai) Company Limited No. 1801 Hongmei Road, Shanghai, 200233, P R China
Sensia LLC 7000 Nix Drive Duncan, Oklahoma 73533-8733 USA	Sensia LLC 200 Westlake Park Blvd Houston, Texas 77079 USA	Sensia Energy SA DE CV Ave Santa Fe 481, Piso 3, Col Cruz Manca, Cuajimalpa, Mexico City, D.F., C.P. 05349, Mexico
Sensia LLC 1000 McClaren Woods Drive Coraopolis, Pennsylvania 15108-7766 USA	Sensia FZE Schlumberger Transitrex Facility, Jebel-Ali P.O. Box 16776, Plot WWA 115, Dubai, U.A.E.	Sensia Energy Private Limited Commercezone, Bldg No.6, Office No. 701, S. No. 144 & 145, Samrat Ashoka Path, YERAWADA, Pune, Maharashtra, India, 411006

sensiaglobal.com

Add intelligent action to your oil and gas solutions

© Sensia LLC 2021. All rights reserved.

sensia
Rockwell Automation + Schlumberger