



**Operation Manual for Hydraulic System**

SunSource Fluid Power Systems

5750 Hillside Avenue

Cincinnati, Ohio 45233

Phone: 800-289-7770

Customer Purchase Order Number: 4511161041

SunSource Job Number: MC31A

**Cameron Jiskoot**

**ISO 9001 : 2008 Certified**

**Your Partner in Fluid Power**

*Dear Valued Customer,*

*SunSource is pleased to provide your custom made hydraulic system.*

*Our Quality Statement is as follows:*

*SunSource will provide our customers with the highest quality products and services focused on continuous improvement of our processes to provide on-time and error-free product and performance.*

*We are happy to meet your needs and are looking forward to continuing an ongoing partnership in the future*

*The following page is an ISO-Customer Complaint form. If there is anything that you are not satisfied with – either in the product or service, it is vital that you we receive your feedback. Please complete the following customer complaint document and fax or mail to:*

*SunSource Fluid Power Systems Group  
5750 Hillside Ave.*

*Cincinnati, OH 45233*

*Fax#: 513-941-0583*

*Your feedback is needed not only to rectify the current situation, but to also ensure we meet all your future needs.*



## ISO-Customer Complaint Form

<b>Documenting Complaint:</b>  WHEN COMPLETED FAX TO: 513-941-0583	<b>Date:</b>
<b>Customer Name, Phone, etc.:</b>	
<b>Description of Problem/Complaint:</b>	
<b>Next Step:</b>	

## **Preface**

Hydraulic systems cannot be operated and maintained without following certain guidelines. We have attempted to compile a list of the most common precautions in use today.

This information is not intended as being all inclusive of recommended hydraulic practices, however the data provided should be considered general good practices to facilitate operation of your hydraulic equipment.

# Installation

1. The most important practice to observe in assembling hydraulic systems is cleanliness. Serious damage can result quickly from foreign material in the system.
2. While in transit or during installation, both hydraulic units and hydraulic components may be subject to many usual conditions. Always inspect for damage or contamination (open ports, cracked or missing plugs, etc.) All hydraulic unit or component parts must be kept tightly plugged until final system connections are made.
3. Install components with secure mounting as required. Follow the schematic provided for piping. A pipe-sizing data sheet is enclosed for reference. Please refer to the chart located in the Flushing Procedures section. Careful attention must be paid to sizing and layout of hydraulic piping. Improper sizing or an excessive number of fittings can lead to loss of power and overheating. Additions to and deletions from the system must be designed into the system. A hydraulic system cannot be added to or capped off like a water system.
4. The importance of cleanliness in installations cannot be overemphasized. Be sure that all pipes are free of dirt, scale and rust. Field-fabricated reservoirs should be wiped down with an oiled, lint-free rag. No visible contaminants should remain in the reservoir. All pipes should be capped during installation to prevent sand and weld spatter from getting into the system.
5. Piping Recommendations: Hydraulic system piping must be clean and adequately sized for satisfactory system operation. If a schematic is provided, it will probably show suggested minimum sizing. Length of runs and practical experience should also be considered. Piping materials such as tubes, hoses and fittings must be clean. Iron pipe is usually the most troublesome. The best way to ensure you are starting with clean pipe is to use pipe that has been cleaned, pickled, lightly oiled and capped. Galvanized pipe should not be used. Be sure to use the proper tubing for your system pressure and pipe rating. Note: All hydraulic lines must be thoroughly flushed prior to connection of the components to the system.
6. Use compressed air to clean fittings as required in accordance with applicable safety precautions.
7. Examine pipe, fittings, hoses and tubing to be certain there are no scale, nicks, burrs or dirt present. Hoses, pipes, and tubing should be capped when stored.
8. Ream pipe and tubing ends to prevent swaged-over material from restricting flow or causing turbulence. Remove loose particles generated by reaming.
9. Never use high-pressure piping on pump inlet lines. The inside diameter is smaller and may restrict flow from reservoir to pump.
10. No burning or welding should be done near open hydraulic systems.
11. When using pipe sealing compound, leave the first two threads (inward) bare to keep sealing material from migrating into the system.

12. Do not use pipe compound on straight threads as this type of fitting depends on an "O" ring for sealing.
13. Select hoses adequate for the working pressures involved in the system. Refer to the schematic.

Hoses should:

Not be applied in configurations less than the published minimum bend radius for each style;

Be clamped at reasonable intervals in a manner to prevent chafing or rubbing between hoses or machine parts;

Be routed around or shielded from hot engine parts or exhaust manifolds or pipes;

Be protected by a grommet or other suitable material when penetrating a deck bulkhead;

Be limited in use to allow flexibility for vibration isolation and to facilitate awkward piping connections.

14. When field-fabricated reservoirs are used, construction should incorporate recognized hydraulic practices. Review selection and installation of hydraulic filters to be sure they meet the minimum recommended guidelines by the system component's manufacturer.
15. Always seal all reservoir openings after cleaning the reservoir. Periodic cleaning and oil changes should be part of every maintenance schedule.

# General Cleaning and Flushing Requirements

## To Achieve and Retain Satisfactory Initial Cleanliness Level

1. Chemically clean and treat internal system surfaces (components, tubes and hoses).
2. Perform hot oil flushing to reach target cleanliness level.
3. Inspect and verify that the cleanliness level was achieved.
4. Follow the proper steps when disassembling the flushing loops to prevent contaminants from penetrating the cleaned system. Seal off all components with plugs, blind flanges, etc.
5. Perform routine maintenance to stabilize contaminant levels to within control targets.

## Strategy for Maintaining Cleanliness After Flushing

1. Prevent new contaminants from entering.
2. Select suitable system filters. New oil should be filled through a system filter or another suitable filter.

All new components and/or modules to be connected to the system must meet the preceding requirements. Perform new cleaning and hot oil flushing after component changes, assembly, disassembly or similar procedures have occurred.

## Flushing Strategy Tips

- Connect circuits in series.
- Components that can be damaged by high fluid velocity or by fluids containing moisture, particles or flushing chemicals should be isolated from the flushing circuit and cleaned individually.
- Components that restrict the flow rate, and thereby increase the pressure drop, should be isolated from the flushing circuit and cleaned individually.
- Manifolds, blocks, pump stations, motors, reservoirs, assemblies and components should be delivered clean according to a specific procedure. If not clean, they must be flushed separately. This also applies where space does not allow flushing of installed piping system.

## **Component Cleanliness Level**

Some components and assemblies are often connected to the main system after flushing. Their level of cleanliness must be at least as good as the desired cleanliness of the main system. The supplier should provide a cleanliness certificate with the components. The system assembler must clean these components according to specified procedures if cleanliness certificates are not available from the supplier. Cleanliness certificates should not be considered valid if the cleaning has not been performed to these requirements.

NOTE: If components contain anticorrosion agents not compatible with the system fluid, flush the components using system oil with 5 to 10 percent degreasing agents added to the flushing fluid. The degreasing agent should be selected to ensure no harm to component seals.

## **System Cleaning Preparation**

### **Mechanical Tube Cleaning**

Precision steel tubes - cut, graded and free from scale and corrosion - should be subjected only to chemical cleaning and hot oil flushing. Welded tubes should be mechanically cleaned inside by a plastic pig. A pig, also referred to as a go-devil or rabbit, is a plug with brushes, scrapers and rollers on its periphery. It moves under the oil pressure through a pipeline and cleans it. This ensures the tubes and tube flanges are smooth and free from slag, welding beads (spatter) and foreign particles.

All tubes and hoses should be inspected and blown with highly filtered industrial compressed air. This removes most of the larger particles made by the cutting of tubes and hoses as well as the mounting of fittings.

### **Components Dismantled Prior to Flushing**

To ensure proper cleaning is achieved in all parts of the system and to avoid damage to sensitive components, certain parts should be by-passed or dismantled during cleaning. Each component or subsystem should be cleaned to the required cleanliness level as a part of a flushing circuit or in separate circuits. Partitioning of the overall system is typically needed to achieve this. To clean the pipe system, disconnect all components and subsystems that restrict the flow and those components that can be damaged during cleaning and flushing.



# **Chemical Cleaning and Hot Oil Flushing**

Each circuit should be connected to achieve the specified fluid velocity and Reynolds number, as well as the fluid pressure in all components, lines and fittings. Avoid flushing configurations that can lead to settling of particles in quiescent zones, dead legs, etc. The pressure and flow capacity of the cleaning/flushing rig must also be considered.

## **Chemical Cleaning**

Chemical cleaning, according to the DEWA DPI System, consists of a specially developed group of chemicals that can be used in series in the same pickling reservoir. DEWA is Greek for “green and vigorous.” DPI stands for degreasing, pickling and inhibiting. Developed by the Norwegian company DPI Chemical Industries AS, this patented system is used in the United Kingdom and other countries. All the chemicals are water-soluble, environmentally friendly and inorganic.

## **The cleaning sequence is divided into five phases:**

### **Phase I -Alkaline Degreasing and Pickling**

Fill the reservoir with pure water. Heat it to 122°F (50°C), up to a maximum of 176°F (80°C). Add Chemical A until it reaches pH 14. By circulating maximum flow rate for 30 minutes, any grease and oil film should have been removed. Control pH and temperature during processing.

### **Phase II - Pickling**

Reduce the fluid pH to 5.5 by adding chemical B. Then add Chemical C until 10 percent (volume) is reached. Circulate maximum flow rate for 60 minutes. Control pH and temperature during processing.

### **Phase III - Neutralizing**

Continue to circulate the fluid as you add Chemical D until reaching pH 7.5. Keep the temperature as in Phase I. Circulate maximum flow rate for 30 minutes. Control pH and temperature.

### **Phase IV - Preservation (corrosive steel)**

A corrosion inhibitor is not required if the time between chemical cleaning and hot oil flushing is less than 24 hours. If this condition is not fulfilled, add 2 to 4 percent (volume) of Chemical E. Continue circulation for 30 minutes without

heating. The fluid is thinned out with 4 to 5 percent water before it drains into the standard sewers. Control pH before draining.

### **Phase V -Drying**

Dry the tubes with warm, dry air within 30 minutes after neutralization. Use high quality filtered and oil/water separated compressed air or cleaned nitrogen. The easiest way to control achieved dryness is to check moisture content during the following hot oil flushing.

### **Minimum Process Equipment Required**

- The pickling unit requires a reservoir, pump, filter and heating facility. It is preferred to have a fluid velocity of 3 m/sec. (106 ft./sec.). The filter should be selected according to the same requirements as for the hot oil flushing rig.
- A supply of dry, clean and warm air or nitrogen is needed. It is important that the air is absolutely free of any oil content.
- Special flanges, manifolds and connectors may be needed to assemble the components to be cleaned in series.

### **Process Control**

To verify proper chemical cleaning, the following measurements must be documented during the process:

- pH analyses
- Temperature
- Volume of chemicals in each phase
- Flow rate

### **Hot Oil Flushing**

Generally speaking, the required cleanliness level to target during flushing is half the level during normal operation. For example, if the normal operation level is ISO 15/13/11, flush to an ISO14/12/10. Requirements for cleanliness levels of both solid particles and moisture should be achieved.

**"...the required cleanliness level to target during flushing is half the level required during normal operation."**

## **Flushing Fluids**

The flushing fluid should be compatible with the fluid used during normal system operation as specified by the client. The viscosity of the fluid at different temperature levels should be specified. As a guideline, standard flushing units normally provide sufficient turbulent flow if the viscosity is in the 10 to 15 cSt range at 104°F (40°C). Ideally, the flushing fluid should obtain that viscosity at no higher than 158°F (70°C).

## **Turbulent Flow, Fluid Velocity, Temperature and Pressure**

With a Reynolds number equal to or greater than 4,000, the fluid is certain to have turbulent flow. This is required to remove particles from the surface inside tubes. To also prevent remaining contaminants from becoming suspended during operation, it is required that: Re-flushing number is equal or greater than 1.2 x Re-in service, but always a minimum of 4,000.

Example: a hydraulic system has a flow rate and tube diameter to achieve Re=3,400 in normal service. Flushing requires a minimum of Re=4,080. The fluid velocity (V) should not be less than 2 to 3 m/sec. (106 ft./sec.) in any part of the flushing loop. This prevents settling of particles inside tubes and hoses.

The coldest part in the flushing loop should have a minimum temperature of 122°F (50°C). This can be achieved by using a minimum flushing fluid supply of 140°F (60°C). In certain cases, this can be achieved only by insulating certain parts of the loop.

The pressure should be held to a minimum 3 to 5 bar (22 to 73 psi), measured downstream from the flushing circuit, before the return line filter and sampling port. Cleaning of ball, plug, butterfly and needle valves is an important part of the hot flush process. To ensure cleanliness has been reached in all zones, the hydraulic valves should be actuated to full-stroke movement during each step of the cleaning process.

## **Flushing Reservoirs, Filter Housings, Cylinders, Accumulators, Pumps and Motors**

Each of these components should be cleaned in separate loops.

- Reservoirs - This is one of the most difficult components of a system to flush. The system reservoir should be cleaned manually then filled with flushing fluid. Use a flushing pump with an in-line filter to circulate and flush the reservoir.

- Filter housings - These units can be connected to the flushing loop or cleaned separately as in the case of the reservoir.
- Cylinders, accumulators, motors and pumps - Clean these separately. The components that have bidirectional movement must be actuated to full movement (stroke) to achieve volume flow of at least 10 times their internal volume.

### **Minimum Flushing Time**

Once samples from the system indicate the specified cleanliness level has been reached, continue flushing for at least 30 more minutes at turbulent flow. This increases the probability of removing adherent particles from tube walls.

### **Verify Flushing Results**

Each flushing loop should be unique and traceable. Create individual drawings or use suitable piping and instrumentation diagrams (P&IDs). Mark position of sampling points for temperature, flow and oil samples.

Document all parameters such as startup time, temperature, flow, particle contamination level and moisture and finish time. It is recommended that a uniform and consistent method of documentation be used.

Third-party verification may be needed to confirm the cleanliness level of the final flushing loop and the complete system.

### **Flushing Skid**

A flushing procedure should be adapted to the conditions of the flushing rig. To obtain sufficient results, the following criteria must be met:

- The filter system should have sufficient capacity and performance to remove both solid particles and moisture to the required level, within a reasonable time.
- The original filters in the system to be flushed should not be used as flushing filters. The flushing filter is important for two essential reasons: 1) it determines the final cleanliness level, and 2) it determines the rate at which this level can be reached.

- A common practice seen lately is to over-specify the filters. A filter with B3>100 with a pressure differential indicator is suitable as long as the dirt-holding capacity is sufficient. Also, it is important for the indicator to provide a warning long before actual fluid by-pass.
- There are several options for moisture removal. These include water-absorbing filter elements, coalescing filters, oil purifiers (such as vacuum distillation), and simply replacing the oil.
- In normal conditions, a water-absorbing filter should be sufficient, assuming the moisture levels are low. Certain synthetic fluids must be dehydrated with oil purifiers.

**NOTE: Flushing filters to remove solid particles should not be replaced by the water-removing filters.**

- The pump unit should deliver flushing fluid with flow, velocity, viscosity and pressure ratings sufficient to clean the internal surfaces in the system. It should also transport the contaminants out of the system and into the downstream flushing filter.
- The fluid temperature should be monitored and controlled to verify that the oil viscosity provides sufficient turbulent flow in all parts of the flushing loop and at values within the specification for the actual flushing pumps.

Although system flushing can be a time-consuming and expensive process, it is often required, especially at the completion of construction and after a catastrophic component failure during service. Additionally, flushing should be performed as part of a periodic proactive maintenance activity for systems in service. Both the duration and cost of the flushing can be reduced if the system is designed for flushing by the equipment builder. Seek to optimize the flushing procedure for all subsystems and components. But first, systemize and manage the flushing as a complete process for all lines and components throughout the entire system. This will provide reliable service that performs according to design specifications.

## References

1. Ito, T. (1984). Hydraulic System Flushing. FRH Journal.
2. Gibbons, Tom. (1998). Improved Flushing Techniques for Turbine Lube Systems. Pall Corporation Presentation.
3. ISO5910 Hydraulic Fluid Power. Cleaning of Hydraulic Pipe Systems.
4. ISO5911 Hydraulic Fluid Power. Methods for Coding Levels of Contamination by Solid Particles.
5. Mator Procedure FP104E rev.01. (1) Pipe System Cleaning and Testing. (2) Chemical Cleaning, Hot Oil Flushing and Pressure Decay Testing.
6. Molen Kjemi AS, DEWA DPI Chemical Cleaning System.
7. Tom Odden, Mator AS, "Cleaning and Flushing Basics for Hydraulic Systems and Similar Machines". Machinery Lubrication Magazine. July 2001

## Start-Up

1. Fill the reservoir with fluid as recommended by the pump manufacturer (see pump data) which usually requires a premium grade hydraulic fluid with a viscosity index of 90 or higher. For applications with temperatures to 130° F, a fluid viscosity of 150 SSU at 100° F will provide a maximum pump service life. Automatic transmission fluid (Dextron Type D2) will usually prove satisfactory.

The reservoir filling should always be done through a 10 or finer micron filter. This may be a fill-line filter or possibly the system return filter. In any case, do not put unfiltered oil into your clean reservoir!

2. Connect electric motors to the proper electrical source, checking the motor nameplate for proper wiring of dual-voltage motors. Jog the motor to check rotation. Polyphase motors are bi-directional and proper rotation can be established by reversing any two power leads. Size the motor wiring for proper motor amperage and voltage per information on the motor nameplate.
3. All pumps and motors with external case drains should have cases filled with hydraulic fluid before running. Just as you would not crank an engine without crankcase oil, these components should not be run without pre-filling and should be plumbed so as not to drain the case.

Check levels and fill all gear boxes where applicable.

### **Caution!**

**Many engine-driven hydraulic pumps are ruined during engine start up. Be sure that the pump is disengaged or is ready to pump with an adequate supply of oil prior to engine start up.**

4. Make sure all suction valves are open and all compensator and relief valves are backed up to the minimum setting. Caution: Relief valves on hydraulic units are preset at pressure shown on the schematics prior to shipment.
5. During start up of the pump, verify that it is priming properly. If the pump fails to prime, shut down immediately, vent discharge pipe to atmosphere and restart to establish fluid flow. Check suction valves to assure that they are open. Loosen hose or pipe connection on pressure side of pump. Jog pump drive and note oil flow to assure prime. Retighten loosened connections after priming. Unusual pump noise is often caused by air entering the pump suction line. The tightening of suction fittings will usually eliminate such problems.

6. Adjust pressure controls to settings recommended on the circuit drawings.
7. The electrical characteristics for electrically-operated valves are shown on the solenoid valve covers.
8. Important: After hydraulic unit has been started and all lines filled, replenish the oil in the reservoir to the proper level. This will insure that the oil cools properly and prevent cavitation of the pump.
9. After the first two (2) hours of system operation, inspect and clean or replace all filter elements to remove any contamination flushed out of the system components. Replacement elements are readily available from SunSource. Repeat this task every two (2) hours for the next eight (8) hours of operation then as needed. (See the Oil Maintenance section.)

**Caution!**

**Simultaneously energizing both solenoids on double solenoid valves will cause coil burnout!**

**Important!**

**For most applications an operating temperature of 150° is considered maximum. At higher temperatures difficulty is often experienced in maintaining reliable and consistent hydraulic control. Component service life is also reduced, hydraulic fluid deteriorates and potential danger to operating personnel is created.**



## **Fluid Maintenance / Filtration**

Contamination in hydraulic fluid has been given a lot of attention by the industry. Research and testing of the effects of dirt, water, wear products, oil deterioration products and other contaminants in the oil are important factors in today's high performance hydraulic equipment.

### **Why Cleanliness?**

The demand for even greater performance from smaller packages has greatly increased the need for keeping the oil clean. Wear occurs in all hydraulic systems. If dirt particles remain suspended in the oil, they act like a grinding compound and increase wear. Other foreign particles, particularly metal, have the same effect.

Hydraulic components are affected by contamination. Sticking and sluggishness can occur. Small controlling passages may become plugged. Dirt can prevent valves from seating, resulting in leakage and loss of control.

Hydraulic oil, itself, is affected by contamination. Water has a tendency to separate certain inhibitors from high-performance hydraulic oil, reducing its usable life. Other contaminants seem to be a catalyst or "helping hand" effect on oil oxidation. It has been demonstrated that fine particulate contamination actually reduces the safe operating temperature of a system. Extremely clean fluids can operate as much as 25° to 50° hotter than contaminated fluids without oxidation.

Hydraulic oil is kept clean by the filters. The periodic replacement of filter elements is mandatory for satisfactory operation. Replace elements immediately upon indication of an installed bypass indicator or every 500 hours of operation once the system is in production.

Hydraulic systems are precision units and their continued smooth operation depends on proper care. Keep them clean, change the oil filter at established intervals and follow prescribed maintenance.

# Maintenance Instructions

## Periodic Procedures

1. Check the reservoir oil level and add oil as required. The level must be maintained between the high and low marks on the sight gauge.
2. Check the operating temperature. 150° is considered maximum for most industrial applications.
3. If an external suction filter is used, check the filter indicator for dirty elements every two (2) hours for the first eight (8) hours of operation then clean or replace when necessary. Check the filter indicator once every day for the next five (5) days of operation and clean or replace when necessary. Check periodically thereafter at intervals that will prevent the filter from bypassing or cavitating the pumps.
4. Check the return filters as in Step 3. These are usually finer mesh filters and will require more frequent element changes or cleansing than the suction filter. Always change filters when the oil is changed.
5. At least once a year or every 4,000 operating hours the reservoir, pump, suction filter (if one is used) and air vent filter should be cleaned. Check the entire system at this time for possible future difficulties. Some applications or environmental conditions may dictate such maintenance is performed at more frequent intervals.
6. Make visual checks of all hose and tube connections. Regular checking and tightening of all hydraulic connections will help to assure trouble-free operation.
7. Periodically check pressure settings. The system was designed to operate at a specific pressure and increasing the pressure above that level will result in motor overload. The system should be operated at the minimum pressure required to do the intended function. The lower the system pressure, the longer system components can be expected to last.
8. Check pump/motor coupling periodically for misalignment. A flexible coupling should always be used with the shafts accurately aligned – parallel and angularly. Check set screws in couplings for loosening and tighten as required.
9. The reservoir cover should remain tightly sealed at all times except in the case of in-tank maintenance and periodic checks for in-tank leaks. This will prevent atmospheric contamination from entering the system.

# Safety Precautions

## Required for Hydraulic Machinery Operation & Maintenance

Although the scope of this manual covers only the hydraulic operation of the equipment, these safety precautions also apply to pneumatically-powered equipment and should be observed when appropriate.

The hydraulic equipment has been constructed using the highest standards of workmanship with industry accepted, state-of-the-art techniques, components and designs and has been inspected and tested for defects, workmanship and proper operation prior to shipment.

This equipment, however, may develop problems due to normal use, unforeseeable circumstances or abuse. It requires, therefore, proper operation and maintenance. In the course of performing these functions, personnel may be required to work on or near the equipment. The following precautions are given to avoid injury.

All safety requirements listed below are those generally applicable to hydraulically-powered machinery but are **not** intended to be an all-inclusive list. They are intended as **guidelines only** and will assist in avoiding risk of injury when followed by qualified, experienced personnel who understand the hazards of machinery operation and maintenance. These precautions should be included in the comprehensive safety program for the particular machinery, equipment, plant or process and overseen by personnel capable of analyzing any hazards associated with operating and maintaining the equipment.

1. Return all movable machine members to their normal startup condition, if possible, before starting unit.

**Note: Many types of equipment may have parts of the machinery which may start rotating, rising, falling, reciprocating, etc. out of their proper sequence as soon as the hydraulic or pneumatic circuit is filled and pressurized which could result in injury to personnel or damage to machinery.**

2. Be sure all personnel, product, etc. are clear of machinery before starting hydraulic unit.
3. Check to make sure any hydraulic connections which may have been removed, replaced or disconnected during shut down have been reconnected securely before starting hydraulic unit.

4. Return all valves (manual and control system operated) which may have been changed from their normal start-up condition during shut down back to start up condition before starting hydraulic unit.
5. Before shutting down hydraulic unit, block or lock in position any machine members which may move and cause injury to personnel or damage to product or equipment upon loss of hydraulic flow and pressure.
6. Clear all personnel and product from machinery before shutting down the hydraulic unit.
7. If hydraulic system has oil accumulators in circuit, drain pressurized oil from all accumulators as soon as hydraulic unit is shut down (if automatic drainage is not built into the circuit). If the accumulator has a shut off valve, close that valve also.
8. Shut down the hydraulic unit and relieve pressure from all pressurized accumulators, actuators and lines before removing, tearing down or performing maintenance on any remotely-located actuators, hoses, filters, valves, piping, etc.
9. Keep in place and maintain any equipment guards including coupling and chain guards and protective cowling. Do not wear loose clothing or jewelry that could get caught in moving parts.
10. In addition to any other company-mandated safety equipment worn by your personnel, make sure anyone in the vicinity of the hydraulic system during operation wears eye protection to reduce the risk of injury in the event of a hydraulic line rupture and high-velocity oil leak.
11. Check noise levels in the vicinity of the equipment and have personnel wear ear protection, if required, as set forth in OSHA regulations.
12. Any personnel observing or working on or adjacent to hydraulically-powered equipment must never place themselves in a location or position that could produce an injury in the event of:
  - a. A hydraulic line failure either with the unit running or shut down,
  - b. Power blackout, or electrical outage,
  - c. Pump or motor failure or,
  - d. Movement of machine members during a normal operating cycle or as a result of a component malfunction or failure.

13. Before removing or performing maintenance on any hydraulic system components containing electrical components (i.e. solenoid valves, switches, electric motors, etc.), shut off and padlock electrical power to the unit and/or control system. See Paragraphs 5 and 12 above before shutting off power. This applies to pneumatically controlled equipment as well.
14. Avoid locating equipment in any environment for which it was not designed and which may create a dangerous operating condition such as an explosive atmosphere (e.g., gas, dust), high heat (e.g., molten metal, furnace), chemicals, extreme moisture, etc.
15. Certain hydraulic fluids may be irritating or injurious to the eyes and skin. Check with your fluid suppliers to obtain this information. Avoid bodily contact with such fluids. Fire resistant or synthetic fluids should be especially guarded against.
16. Avoid the use of unauthorized or substitute parts and materials when servicing the equipment. Substitute parts or materials could produce a hazardous operating condition.
17. When piping your equipment, use only materials of adequate size and strength to suit the flows and pressures of the system. If a schematic has been provided, it will normally note the minimum suggested line sizes and lengths of runs. Practical experience may indicate use of line sizes larger than shown on the schematic. Consider all safety factors when selecting the strength of materials to allow for shock and over-pressure conditions which could occur.

# Trouble Shooting Your Hydraulic System (Pg 1)

PROBLEM	POSSIBLE CAUSES	REMEDY
<u>Failure of pump to deliver fluid</u>	Low fluid level in reservoir	Add recommended oil and check level to be certain pump suction line inlet is submerged deeply enough to prevent air entering directly or by the formation of a vortex.
	Oil intake pipe or strainer plugged	Clean or replace
	Air leak in suction line, prevent priming or causing noise and irregular action of control circuit	Repair leaks
	Oil viscosity too heavy to pick up prime (especially in cold weather)	Use lighter viscosity oil or install a low density immersion heater (with steel element only)
	Wrong direction of rotation	Must be reversed to prevent damage to pump
	Broken pump shaft or parts broken inside pump	Replace
<u>Pump making noise</u>	Intake line, suction filter or pipe restricted	Clean intake, filter or eliminate restriction. Be sure suction line is completely open
	Air leaks	1) Tighten as required
	1) At pump intake piping joints 2) At pump shaft packing (if present) or seals 3) Air drawn in through inlet pipe opening	2) Repair or replace  3) Be sure suction and return lines are below oil level in reservoir
	Reservoir air vent plugged	Air must be allowed to breathe in the reservoir. Clean or replace reservoir breather.
	Too high oil viscosity	Use lower viscosity oil. Check recommendations in start-up information
	Coupling misalignment	Re-align
	Worn or broken parts	Replace

## Trouble Shooting Your Hydraulic System (Pg 2)

PROBLEM	POSSIBLE CAUSES	REMEDY
No pressure in the system	Pump does not deliver	Follow the remedies given for "Failure of Pump to Deliver Fluid"
	Bad pump-to-motor shaft connection	Check pump/motor coupling for breakage, stripped key or keyway and replace or repair
No pressure in circuit with Variable Volume Piston Pumps	Relief Valve Malfunction	
	1) Incorrect valve setting	1) Reset to specifications
	2) Valve leading or by-passing	2) Check main valve seat and pilot valve for scoring and dirt. Replace and clean
	3) Valve spring broken	3) Replace spring and reset
	Free re-circulation of oil to tank being allowed through system.	Check or relief valve may be stuck in open position or return line open unintentionally Vent Valve* is dumping flow through relief valve at low pressure. Bypass valve to tank is open.
		Open center 4-way Valve* is not shifted, dumping oil to tank. See "Solenoid Valve not Shifting" if valve is solenoid operated.
	Pressure compensated pump not compensating properly.	Check compensator for broken spring or contamination and repair as required.
	Relief valve setting is lower than pump compensator setting	Set relief to max system pressure and pump compensator to operating pressure at least 250 psi below relief.
	Hydrostatic drive not building torque (no system pressure)	See remedies in "Hydrostatic Troubleshooting" provided by the pump manufacturer.

## Trouble Shooting Your Hydraulic System (Pg 3)

PROBLEM	POSSIBLE CAUSES	REMEDY
<p>Excessive wear of pump parts</p> <hr/>	<p>Sustained high-pressure above maximum pump rating            Drive misalignment            Air recirculation causing chatter in system            Abrasive material in the oil</p>	<p>Check relief valve maximum setting.            Check and correct.            Check air problems in pump making noise.            Clean or replace filter and change oil.            Check recommendations.</p>
<p>Breakage of inside pump Housing</p> <hr/>	<p>Viscosity of oil too low at working conditions            Excessive pressure above pump rating            Seizure due to lack of oil</p>	<p>Check relief valve maximum setting.            Check reservoir level, oil filter and possibility of restriction in suction line.            Replace.</p>
<p>External oil leakage around pump shaft or housing</p> <hr/>	<p>Shaft packing or seals worn</p> <p>Damaged head packing seals excessive case pressure due to restricted case drain flow (back to tank)</p> <p>Excessive case pressure due to excessive drain flow</p> <p>Cracked housing</p>	<p>Replace.            Check case drain line for a restriction and remove. Drain line may be too small; if small, line is creating back pressure, replace with larger line.            Repair pump for excessive leakage from pumping element to case.            Replace all damaged parts and seals.</p>



## Trouble Shooting Your Hydraulic System (Pg 4)

PROBLEM	POSSIBLE CAUSES	REMEDY
<u>Solenoid valve problem</u>	Solenoid burned out	<p>Replace solenoid coil. Check control voltage (high or low voltage will burn out coil).</p> <p>For double solenoid valves, check to see if both solenoids are being energized at the same time. Correct control circuit if this occurs.</p>
	No pilot pressure for shifting main spool	<p>If valve is externally piloted, check pilot pressure source for adequate pressure.</p>
	No pilot pressure for shifting main spool (continued)	<p>Check valve for proper internal plugs for ext. pilot.</p> <p>If valve is internally piloted, check for proper internal plugs for internal pilot.</p> <p>Clean all internal pilot passages and orifices of foreign particles and clogging.</p>
	No pilot drain	<p>Check to see if valve has proper internal plugs and orifices for inter. or ext. drain.</p> <p>If externally drained, check drain line and clear of any clogging.</p>
	Spool jammed by foreign particles of silt	<p>Disassemble pilot valve and main valve and remove all foreign particles and silt. If a contamination or silting problem continues to reoccur, install filtration in the system to remove particles.</p>
	Internal breakage or damage	<p>Disassemble, examine and replace any damaged parts in pilot valve or main valve.</p>

## Trouble Shooting Your Hydraulic System (Pg 5)

PROBLEM	POSSIBLE CAUSES	REMEDY
<u>Cylinder won't develop full force or hold position when valve closes lines</u>	Leaking piston packing	Apply pump flow to one end and stroke cylinder until it bottoms out at end of stroke. Loosen return line at opposite end (from pressurized end) and measure leakage flow coming out. Any flow more than slow dripping requires new piston packing. Repeat for opposite end and stroke.
	Worn 4-way control valve	Disconnect cylinder lines at 4-way valve and plug. Shift valve to either position and check to see if full pressure builds up. If relief is not built into 4-way valve, check to see how much flow is leaking across to the tank port.
	Loss of system pressure	See previous trouble shooting guide.
<u>Cylinder loses force at some intermediate point in stroke</u>	Scored barrel	Repeat above except mechanically stop piston rod so piston is at point where force drops off. If leakage is determined, barrel must be repaired or replaced.
	Dented barrel	Examine barrel tube for dents at point where it loses force. Replace if tube is dented.

## Trouble Shooting Your Hydraulic System (Pg 6)

<b>PROBLEM</b>	<b>POSSIBLE CAUSES</b>	<b>REMEDY</b>
<u>Excessive heating because of component conditions</u>	Relief valve set incorrectly	Readjust valve to system specifications pressure; usually 100-150 psi above compensator setting. Repair or replace pump.
	Internal oil leakage (pump)	
	Viscosity of oil too high	Check recommendations to start-up information. Repair or replace.
	Leaking valves	
	Improper functioning of oil cooler (if installed)	Inspect cooler and see that it is working properly.
	Restricted lines	If lines are crimped, replace; if partially plugged for any reason, remove obstruction.
	Scored or damaged rotor, valve plate, pistons and piston bores, or other internal moving parts	Check case drain line for excessive drain flow; if possible filter drain flow and check for metal (brass or steel) filings or particles; replace damaged parts.

# Electric Motor Trouble Shooting (Pg 1)

PROBLEM	POSSIBLE CAUSES	REMEDY
<u>Motor runs excessively hot</u>	Overloaded	Reduce load or load peaks and number of starts in cycle.
	Blocked ventilation	Clean external ventilation system-check fan.
	a. TEFC's	Blow out internal ventilation passages.
	b. O.D.P.'s	Eliminate external interference to motor ventilation.
	High ambient temperature over 40 C (104 F)	Reduce ambient temperature or provide outside source of cooler air.
	Unbalanced input current	Balance supply voltage. Check motor leads for tightness.
<u>Won't start (just hums and heats up)</u>	Single Phased	Eliminate single ph. condition.
	Single Phased	Shut power off. Eliminate single phasing. Check motor leads for tightness.
	Rotor or bearings locked.	Shut power off. Check shaft for freeness of rotation.  Be sure proper sized overload relays are in each of the 3 phases of starter. Refer to National Electrical Code.
<u>Runs noisy under load (excessive electrical noise or chatter under load)</u>	Single Phases	Shut power off. If motor cannot be restarted, it is single phased. Eliminate single phasing.  Be sure proper sized overload relays are in each of the 3 phases of the starter. Refer to National Electrical Code.
<u>Excessive voltage drop (more than 2 or 3% of nominal supply voltage)</u>	Excessive starting or running load	Reduce load.
	Inadequate power supply. Undersized supply lines. High resistance connections.	Consult power company. Increase line sizes. Check motor leads and eliminate poor connections.

## Electric Motor Trouble Shooting (Pg 2)

PROBLEM	POSSIBLE CAUSES	REMEDY
<hr/> Overload relays tripping upon starting	Slow starting (10-15) seconds or more) due to high inertia load.	Reduce starting load. Increase motor size if necessary.
<hr/> Running loaded	Low voltage at motor Terminals Overload	Improve power supply and/or increase line size. Reduce load or increase motor size.
	Unbalanced input current	Balance supply voltage.
	Single phasing	Eliminate.
	Excessive voltage drop	Eliminate (see below).
	Too frequent starting or intermittent overloading	Reduce frequency of starts and overloading or increase motor size
	High ambient starter temperature	Reduce ambient temperature or provide outside source of cooler air.
	Wrong size relays	Correct size per nameplate current of motor. Relays have built in allowances for service factor current. Refer to National Electrical Code.
<hr/> Excessive vibration (mechanical)	Out of balance:	
	a. Motor mounting	Be sure motor mounting is tight and solid.
	b. Load	Disconnect belt or coupling- restart motor-if vibration stops, the unbalance was in load.
	c. Sheaves or coupling	Remove sheave or coupling-securely tape 1/2 key in shaft keyway and restart motor-if vibration stops, the unbalance was in the sheave or coupling.
	d. Motor	If the vibration does not stop after checking a, b, and c above, the unbalance is in the motor-replace the motor.
	e. Misalignment on close coupled application	Check and realign motor to the driven machine.

## Electric Motor Trouble Shooting (Pg 3)

PROBLEM	POSSIBLE CAUSES	REMEDY
<p>Noisy Bearings: (listen to bearings for the following)</p> <hr/>		
Smooth mid range hum	Normal fit	Bearing OK.
High whine	Internal fit of bearing too tight	Replace bearing-check fit.
Low rumble	Internal fit of bearing too loose	Replace bearing-check fit.
Rough clatter	Bearing destroyed	Replace bearing-avoid: <ol style="list-style-type: none"> <li>a. mechanical damage</li> <li>b. excessive greasing</li> <li>c. wrong grease</li> <li>d. solid contaminants</li> <li>e. water running into motor</li> <li>f. misalignment on close coupled application</li> <li>g. excessive belt tension</li> </ol>
<hr/>		
High input current (all three Phases)	Accuracy of ammeter readings	First check accuracy of ammeter readings on all three phases.
<hr/>		
Running idle (disconnected from load)	High line voltage 5 to 10% over nameplate	Consult power company-possibly decrease by using lower transformer tap.
<hr/>		
Running loaded	Motor overload	Reduce load or use larger motor.
	Motor voltage rating does not match power system voltage	Replace motor with one of correct voltage rating. Consult power company-Possibly correct by using a different transformer tap.

CUSTOMER Cameron (Jiskoot)  
JOB # NI22A

<b>DESCRIPTION</b>	<b>MANUFACTURER</b>	<b>ENGINEERING INFORMATION ENCLOSED</b>
P562448	DONALDSON	X
P562603	DONALDOSN	X
CEM7014T-I-5	BALDOR	X
35FH5000A04SP	BALDOR	X
150499	VESCOR	X
10426	VESCOR	X
V101P2P1C20	VICKERS	X
SS10003	ZINGA	X
PME-2667A-3	HYDRO-CRAFT	X
RV1010S05	VICKERS	X
P551551	DONALDSON	X
D04B2-2.1N	PARKER	X
HCRS-30D	HYDRO-CRAFT	X
9692058	WIKA	X
NMF20BK	DELTROL	X
PME-3030A	HYDR-CRAFT	X
DG4V3S2AMX2H460	EATON VICKERS	X
AD03CPP	DAMAN	X

# **BALDOR**® • *RELIANCE*

## Product Information Packet

# CEM7014T-I-5

1HP,1760RPM,3PH,60HZ,143TC,3519M,XPFC,F1



Part Detail							
Revision:	B	Status:	PRD/A	Change #:		Proprietary:	No
Type:	AC	Prod. Type:	3520M	Elec. Spec:	35WGM849	CD Diagram:	CD0006
Enclosure:	XPFC	Mfg Plant:		Mech. Spec:	35X732	Layout:	35LYX732
Frame:	143TC	Mounting:	F1	Poles:	04	Created Date:	08-25-2015
Base:	RG	Rotation:	R	Insulation:	F	Eff. Date:	10-28-2016
Leads:	3#18					Replaced By:	
Literature:		Elec. Diagram:					

Nameplate NP0977XPSLEV										
NO.						CC	010A			
SER.							TEMP CODE	T3C		
SPEC.	35X732M849G3									
CAT.NO.	CEM7014T-I-5									
HP	1									
VOLTS	575									
AMPS	1.2									
RPM	1760					MOTOR WEIGHT	51			
HERTZ	60	PH	3	CL	F	DE BRG	6205			
SER.F.	1.15	DES	B	CODE	L	ODE BRG	6203			
FRAME	143TC		GREASE	POLYREX EM						
RATING	40C AMB-CONT 55C AMB AT 1.0 SF									
USABLE AT 208V						NEMA-NOM-EFF	85.5		PF	71
	NEMA MG-1 PT 5,IP55									

Parts List		
Part Number	Description	Quantity
SA306163	SA 35X732M849G3	1.000 EA
RA293399	RA 35X732M849G3	1.000 EA
34FN3002B01	EXTERNAL FAN, PLASTIC, .637/.639 HUB W/	1.000 EA
35CB1005A01	CONDUIT BOX,MACH - GROUP "C" MTRS	1.000 EA
11XW1032G06	10-32 X .38, TAPTITE II, HEX WSHR SLTD U	1.000 EA
HW3001B01	BRASS CUP WASHER, FOR #8 SCREW	1.000 EA
35EP3700B07	FR ENDPLATE, XPFC - GROUP C, W/ DRAIN	1.000 EA
HW4506A02	BREATHER/DRAIN-EXP PROOF-.125-27 NPTF AI	1.000 EA
HW3022E05	.125 DIA X .500 ROLLED SPRING PIN	1.000 EA
HW5100A03SP	WAVY WASHER (W1543-017)	1.000 EA
HA2009A89	SPACER FOR XP MTRS - 205 BRG.	1.000 EA
35EP1704A40	PUEP 205 BRG XP,GP C,ALUM SLINGER,DRAIN	1.000 EA
HW4506A02	BREATHER/DRAIN-EXP PROOF-.125-27 NPTF AI	1.000 EA
HW3022E05	.125 DIA X .500 ROLLED SPRING PIN	1.000 EA
51XN1032A20	10-32 X 1 1/4 HX WS SL SR	2.000 EA
HW4001A01	1/4 HX SOC PIPE PLG (F/S) ALLOY STEEL W/	2.000 EA
60XN1032A07	10-32 X 1/2 TRUSS HEAD, TORX SERRATED ZN	2.000 EA
XY3118A12	5/16-18 HEX NUT DIRECTIONAL SERRATION	4.000 EA
35FH4005A01SP	IEC FH NO GREASER W/PRIMED	1.000 EA
51XW1032A06	10-32 X .38, TAPTITE II, HEX WSHR SLTD S	3.000 EA
35CB1501A01	CONDUIT BOX LID, MACH. - GROUP "C" MTRS	1.000 EA
RM1020A41	O-RING, -150 BUNA-N, .103 CS X 2.862 ID	1.000 EA
HA2071A02	SLINGER ALUM (AUTO)	1.000 EA
80XN1032A04	10-32 X 1/4 SET SCREW	1.000 EA

<b>Parts List (continued)</b>		
<b>Part Number</b>	<b>Description</b>	<b>Quantity</b>
HW2501D13	KEY, 3/16 SQ X 1.375	1.000 EA
HA7000A01	KEY RETAINER 7/8" DIA SHAFT	1.000 EA
85XU0407S04	4X1/4 U DRIVE PIN STAINLESS	6.000 EA
LB1359F	ALUM XP CAUTION LABEL	1.000 EA
MJ1000A02	GREASE, POLYREX EM EXXON (USe 4824-15A)	0.050 LB
51XB1214A16	12-14X1.00 HXWSSLD SERTYB	1.000 EA
MG1025G29	WILKOFASST, 789.229, DARK CHARCOAL GRAY	0.017 GA
HA3104A06	THRUBOLT 5/16-18 X 8.50 OHIO ROD	4.000 EA
LB1119N	WARNING LABEL	1.000 EA
LC0006	CONNECTION LABEL	1.000 EA
NP0977XPSLEV	SS XP UL CSA-EEV CC CL-I GP-C&D	1.000 EA
G7PA1000	PKG GRP, PRINT PK1034A06	1.000 EA
MN416A01	TAG-INSTAL-MAINT no wire (1000/bx) 11/14	1.000 EA

**AC Induction Motor Performance Data**

Record # 50388 - Typical performance - not guaranteed values

<b>Winding:</b> 35WGM849-R007	<b>Type:</b> 3520M	<b>Enclosure:</b> XPFC
-------------------------------	--------------------	------------------------

Nameplate Data				575 V, 60 Hz: Single Voltage Motor	
Rated Output (HP)	1			Full Load Torque	2.99 LB-FT
Volts	575			Start Configuration	direct on line
Full Load Amps	1.2			Breakdown Torque	13.3 LB-FT
R.P.M.	1760			Pull-up Torque	8.11 LB-FT
Hz	60	Phase	3	Locked-rotor Torque	8.38 LB-FT
NEMA Design Code	B	KVA Code	L	Starting Current	9.77 A
Service Factor (S.F.)	1.15			No-load Current	0.84 A
NEMA Nom. Eff.	85.5	Power Factor	71	Line-line Res. @ 25°C	23.9 Ω
Rating - Duty	40C AMB-CONT			Temp. Rise @ Rated Load	36°C
S.F. Amps				Temp. Rise @ S.F. Load	42°C
				Locked-rotor Power Factor	53.9
				Rotor inertia	0.118 LB-FT <sup>2</sup>

Load Characteristics 575 V, 60 Hz, 1 HP

% of Rated Load	25	50	75	100	125	150	S.F.
Power Factor	29	47	60	69	76	80	75
Efficiency	74.4	83.2	85.2	85.9	85.3	84.4	85.5
Speed	1790	1780	1770	1760	1748	1735	1754
Line amperes	0.872	0.977	1.1	1.26	1.46	1.68	1.35

Performance Graph at 575V, 60Hz, 1.0HP Typical performance - Not guaranteed values

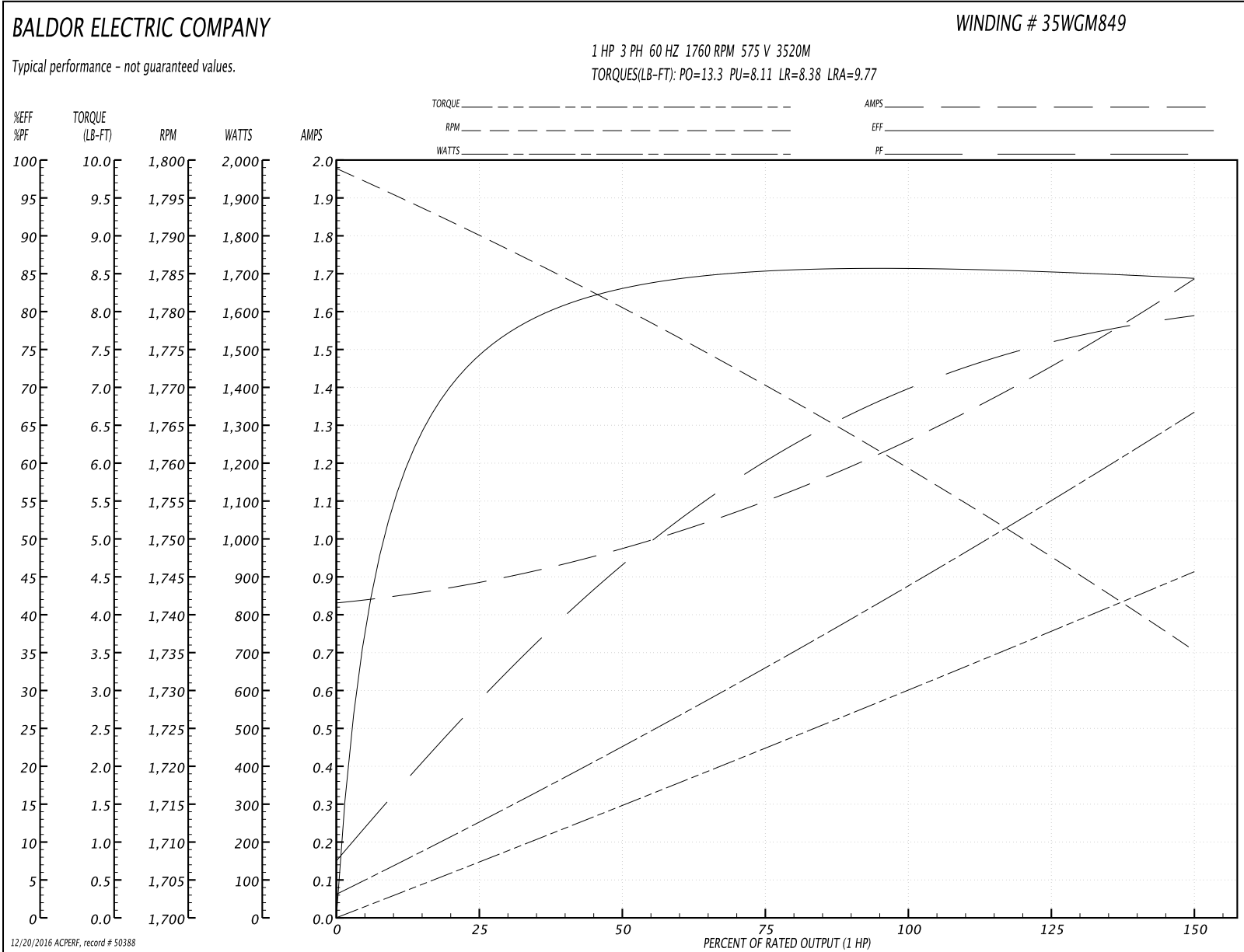

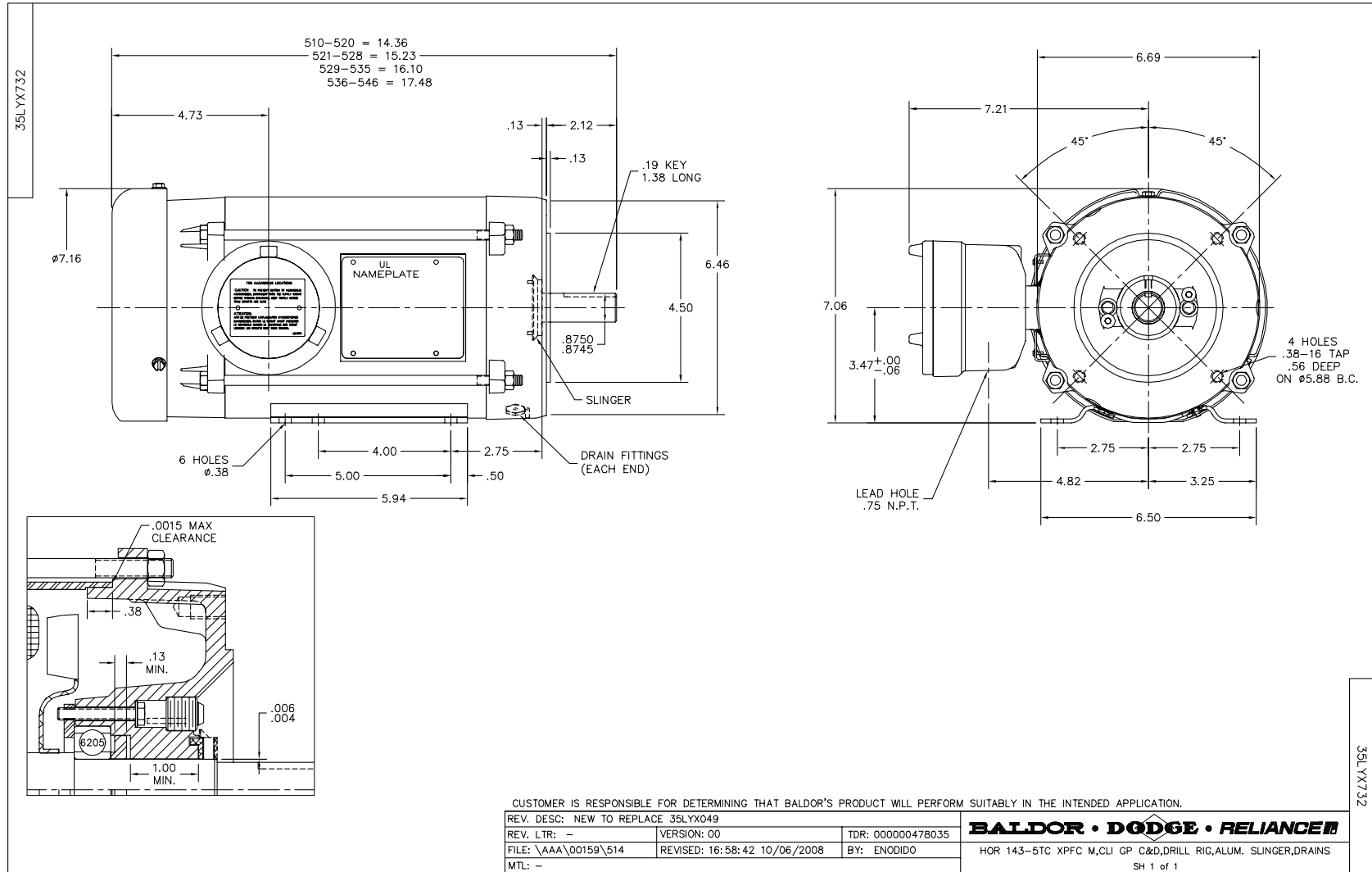

CD0006

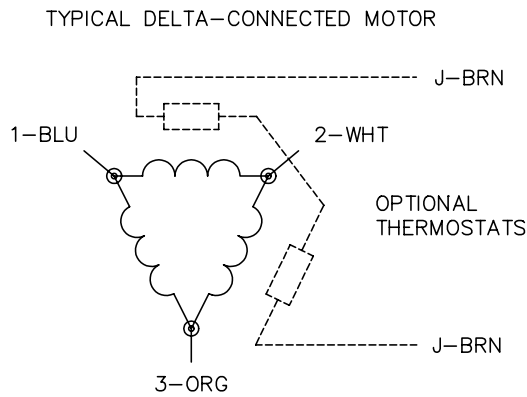
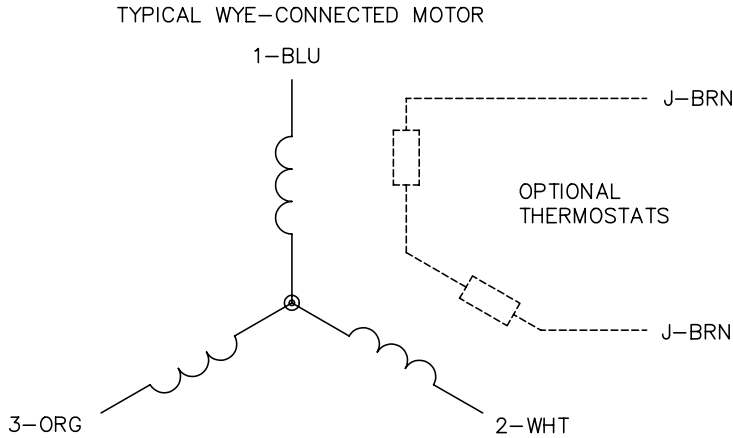

NOTES:

1. THREE LEAD MOTOR MAY BE EITHER WYE CONNECTED OR DELTA CONNECTED.
2. INTERCHANGE ANY TWO LINE LEADS TO REVERSE ROTATION.
3. OPTIONAL THERMOSTATS ARE PROVIDED WHEN SPECIFIED.
4. ACTUAL NUMBER OF INTERNAL PARALLEL CIRCUITS MAY VARY.
5. LEAD COLORS ARE OPTIONAL. LEADS MUST BE NUMBERED AS SHOWN.

REV. DESC: REVISE TO SHOW OPTIONAL COLORS			
REV. LTR: D	BY: JLP	REVISED: 01/21/99 4:02	TDR: 0171435
9000D		FILE: AAA00005141	MDL: -
		MTL: -	

**BALDOR ELECTRIC Co.**

3PH, SV, 3 LEADS, WYE OR DELTA CONNECTED

CD0006



**Description:**

Ultrasonically welded polyamide  
 Suitable for pressurized reservoirs  
 (260 *psi* max.)  
 Maximum operating temperature:  
 212°F / 100°C  
 Scale: 32°F to 212°F / 0°C to 100°C  
 Maximum wall thickness:  
 LG-3 - 1/2", LG-5/LG-10 - 3/8"  
 BunaN O-Ring seals  
 Zinc plated bolts

**Note:** Any contact with alcohol, alcohol-based washing fluids, or petroleum distillates must be avoided. Do not chamfer tank mounting holes.



**Options:**

- 1/2-13 bolts (LG-5)
- Protective guard (LG-5)
- Viton seals
- Red and blue thermometers
- Alcohol resistant version
- Fast mount kit (requires no internal access or threads to mount)

**Fast Mount Assembly Instructions**

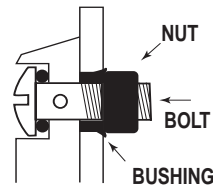

**Installation:** Tighten nuts on bolts to the point where nuts are snug against bushings. Apply one drop of thread lock to last exposed thread at end of bolts. Mount on tank and tighten to 7 in. lbs. (DO NOT OVER-TIGHTEN).

**Removal:** Loosen bolts and remove. (IMPORTANT: THREAD LOCK PREVENTS OVER-LOOSENING OF BOLTS TO POINT WHERE NUTS DROP OFF INTO TANK.)

LG Series

LGZ Series

LG-5G Guard

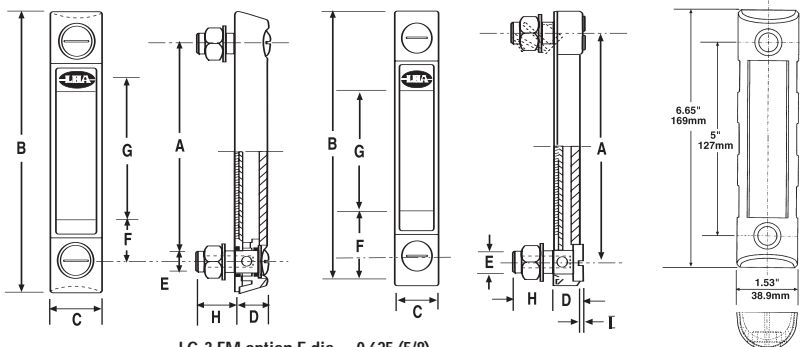

LG-3 FM option E dia. = 0.625 (5/8)  
 LG-5, 10 FM option E dia. = 0.688 (11/16)

Bolt torque: 9 in./lbs.  
 (7 in./lbs. fast mount)

**Fluid Level Gauge Guard (LG-5 Series only)**

Donaldson Part No.	LHA Part No.	Description	Bolt Center Dim. A	Dim. B	Dim. C	Dim. D
P562453	LG-G	5" Level Gauge Guard	5.00/127	6.65/169	1.53/39	.98/25

## Transparent Polyamide Fluid Level Gauges

Donaldson Part No.	LHA Part No.	Description	Bolt Center		Hole Dia.			Bolt Size	Dim. F	Dim. G	Dim. H	Dim. I
			Dim. A	Dim. B	Dim. C	Dim. D	Dim. E					
P562438	LG-3	3" Level Gauge	3.00/76	4.17/106	1.06/27	.63/16	.42/10	M10 x 1.5	.71/18	1.31/33	.83/21	
P562440	LG-3-FM	3" Level Gauge w/ Fast Mount kit	3.00/76	4.17/106	1.06/27	.63/16	.625/16	M10 x 1.5	.71/18	1.31/33	.83/21	
P562441	LG-3-T	3" Level Gauge w/ Red Thermometer	3.00/76	4.17/106	1.06/27	.63/16	.42/10	M10 x 1.5	.71/18	1.31/33	.83/21	
P562442	LG-3-TB	3" Level Gauge w/ Blue Thermometer	3.00/76	4.17/106	1.06/27	.63/16	.42/10	M10 x 1.5	.71/18	1.31/33	.83/21	
P562443	LG-3-T-FM	3" Level Gauge w/ Blue Thermometer & Fast Mount kit	3.00/76	4.17/106	1.06/27	.63/16	.625/16	M10 x 1.5	.71/18	1.31/33	.83/21	
P562454	LG-Z-3	3" Level Gauge	3.00/76	3.90/99	.90/22	.57/14.5	.42/10	M10 x 1.5	.70/18	1.30/33.6	.90/23	0.06/1.5
P562455	LG-Z-3-T	3" Level Gauge w/ Red Thermometer	3.00/76	3.90/99	.90/22	.57/14.5	.42/10	M10 x 1.5	.70/18	1.30/33.6	.90/23	0.06/1.5
P562444	LG-5	5" Level Gauge	5.00/127	6.34/161	1.22/31	.71/18	.47/12	M12 x 1.75	.90/23	2.91/74	.90/23	
P562445	LG-5-13	5" Level Gauge w/ 1/2" -13 bolt kit	5.00/127	6.34/161	1.22/31	.71/18	.50/13	1/2 - 13 UNC	.90/23	2.91/74	.90/23	
P563910	LG-5-AR	5" Level Gauge, Alcohol resistant	5.00/127	6.34/161	1.22/31	.71/18	.47/12	M12 x 1.75	.90/23	2.91/74	.90/23	
P563911	LG-5-AR-FM	5" Level Gauge, Alcohol resistant w/Fast Mount kit	5.00/127	6.34/161	1.22/31	.71/18	.688/17.5	M12 x 1.75	.90/23	2.91/74	.90/23	
P562447	LG-5-FM	5" Level Gauge w/ Fast Mount kit	5.00/127	6.34/161	1.22/31	.71/18	.688/17.5	M12 x 1.75	.90/23	2.91/74	.90/23	
P562448	LG-5-T	5" Level Gauge w/ Red Thermometer	5.00/127	6.34/161	1.22/31	.71/18	.47/12	M12 x 1.75	.90/23	2.91/74	.90/23	
P562449	LG-5-T-13	5" Level Gauge w/ Red Thermometer & 1/2"-13 bolt kit	5.00/127	6.34/161	1.22/31	.71/18	.50/13	1/2 - 13 UNC	.90/23	2.91/74	.90/23	
P563912	LG-5-T-AR	5" Level Gauge w/ Red Thermometer, Alcohol Resistant	5.00/127	6.34/161	1.22/31	.71/18	.47/12	M12 x 1.75	.90/23	2.91/74	.90/23	
P562450	LG-5-TB	5" Level Gauge w/ Blue Thermometer	5.00/127	6.34/161	1.22/31	.71/18	.47/12	M12 x 1.75	.90/23	2.91/74	.90/23	
P562451	LG-5-T-FM	5" Level Gauge w/ Red Thermometer & Fast Mount kit	5.00/127	6.34/161	1.22/31	.71/18	.688/17.5	M12 x 1.75	.90/23	2.91/74	.90/23	
P563913	LG-5-T-G	5" Level Gauge w/ Red Thermometer & Guard	5.00/127	6.34/161	1.22/31	.71/18	.47/12	M12 x 1.75	.90/23	2.91/74	.90/23	
P562452	LG-5-T-SS	5" Level Gauge w/ Red Thermometer, Stainless Bolt kit	5.00/127	6.34/161	1.22/31	.71/18	.47/12	M12 x 1.75	.90/23	2.91/74	.90/23	
P562456	LG-Z-5	5" Level Gauge	5.00/127	5.9/150	.90/22	.57/14.5	.47/12	M12 x 1.75	.93/23.5	2.90/73.7	.90/23	0.06/1.5
P562457	LG-Z-5-T	5" Level Gauge w/ Red Thermometer	5.00/127	5.9/150	.90/22	.57/14.5	.47/12	M12 x 1.75	.93/23.5	2.90/73.7	.90/23	0.06/1.5
P562458	LG-Z-5-V	5" Level Gauge w/ Viton seals	5.00/127	5.9/150	.90/22	.57/14.5	.47/12	M12 x 1.75	.93/23.5	2.90/73.7	.90/23	0.06/1.5
P562434	LG-10	10" Level Gauge	10.00/254	11.42/290	1.38/35	.71/18	.47/12	M12 x 1.75	1.02/26	7.60/193	.90/23	
P562435	LG-10-LF	10" Level Gauge w/ Level Float	10.00/254	11.42/290	1.38/35	.71/18	.47/12	M12 x 1.75	1.02/26	7.60/193	.90/23	
P562436	LG-10-T	10" Level Gauge w/ Red Thermometer	10.00/254	11.42/290	1.38/35	.71/18	.47/12	M12 x 1.75	1.02/26	7.60/193	.90/23	
P562437	LG-10-TB	10" Level Gauge w/ Blue Thermometer	10.00/254	11.42/290	1.38/35	.71/18	.47/12	M12 x 1.75	1.02/26	7.60/193	.90/23	
P563909	LG-10-TB-SS	10" Level Gauge w/ Blue Thermometer & Stainless Bolt kit	10.00/254	11.42/290	1.38/35	.71/18	.47/12	M12 x 1.75	1.02/26	7.60/193	.90/23	

# ABB Series Filler Breathers - Bayonet Style

## Description:

Chrome plated, epoxy coated or zinc plated steel caps  
 Air flow to 30 CFM  
 Compatible with petroleum based fluids  
 30 mesh technopolymer basket  
 Self tapping screws for flange mount  
 Cork gaskets  
 3, 10, or 40 micron

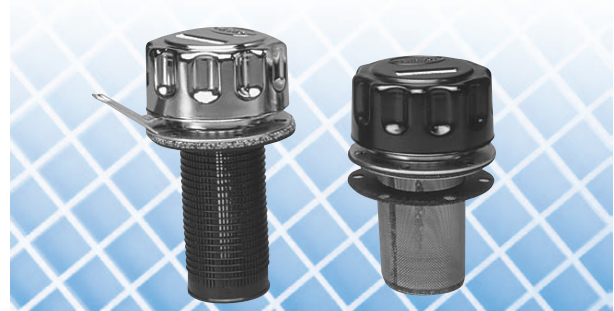

### STAINLESS STEEL BASKETS

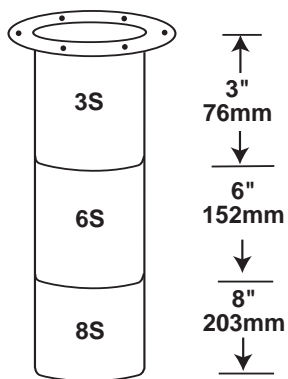

### INNER GUARDS

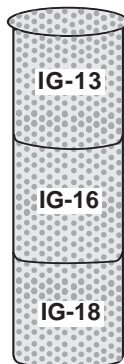

### LOCKING TABS (AB ONLY)

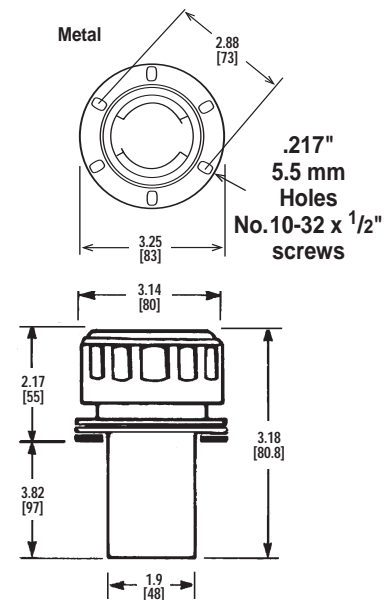
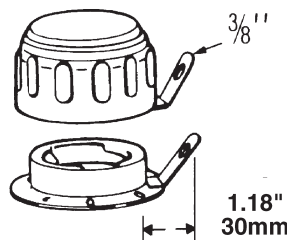

Donaldson Part No.	LHA Part No.	Features	Micron Rating	Airflow Capacity (CFM)	Finish
P562610	ABB-W-03-8S-IG	8" STAINLESS BASKET, INNER GUARD	3	30	Epoxy Coated, Black
P563793	ABB-W-10	FLANGE, SCREWS & GASKET, NO BASKET	10	30	Epoxy Coated, Black
P562611	ABB-W-10-3S	3" STAINLESS BASKET	10	30	Epoxy Coated, Black
P562612	ABB-W-10-3S-LT	3" STAINLESS BASKET, LOCK TAB	10	30	Epoxy Coated, Black
P562613	ABB-W-10-3S-R	3" STAINLESS BASKET, BUNA GASKET	10	30	Epoxy Coated, Black
P562614	ABB-W-10-N	NYLON BASKET	10	30	Epoxy Coated, Black
P562615	ABB-W-10-N-LT	NYLON BASKET, LOCK TAB	10	30	Epoxy Coated, Black
P562616	ABB-W-10-N-R	NYLON BASKET, BUNA GASKET	10	30	Epoxy Coated, Black
P562617	ABB-W-10-N-SMB	NYLON BASKET, SIDE MOUNT KIT	10	30	Epoxy Coated, Black
P562618	ABB-W-40-3S	3" STAINLESS BASKET	40	30	Epoxy Coated, Black
P562619	ABB-W-40-6S	6" STAINLESS BASKET	40	30	Epoxy Coated, Black
P562620	ABB-W-40-N	NYLON BASKET	40	30	Epoxy Coated, Black
P562621	ABB-W-40-N-R	NYLON BASKET, BUNA GASKET	40	30	Epoxy Coated, Black
P562623	ABB-Z-40-3S	3" STAINLESS BASKET	40	30	Zinc Plated
P562624	ABB-Z-40-3S-LT	3" STAINLESS BASKET, LOCK TAB	40	30	Zinc Plated
P562625	ABB-Z-40-N	NYLON BASKET	40	30	Zinc Plated
P562626	ABB-Z-40-N-R	NYLON BASKET, BUNA GASKET	40	30	Zinc Plated

**SIDE MOUNT**

Can be used with all Bayonet and Threaded Flange Breathers (except MBB & Pressurized Breathers). Maximum torque for fastening 112 in. lbs. with washers.

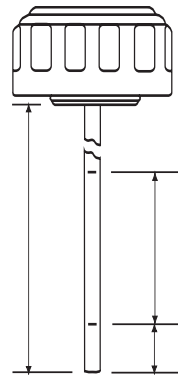
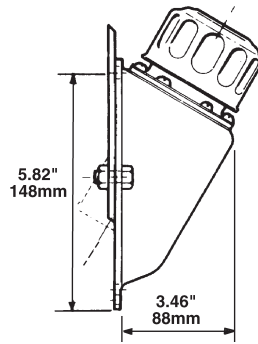

Dipsticks available for some models. See Features section on assembly tables.

Donaldson Part No.	LHA Part No.	Features	Micron Rating	Airflow Capacity (CFM)	Finish
P563785	ABB-03 CWLTF	LOCK TAB FLANGE, SCREWS & GASKET, NO BASKET	3	30	Chrome
P562573	ABB-03-N	NYLON BASKET	3	30	Chrome
P562574	ABB-10	FLANGE, SCREWS & GASKET, NO BASKET	10	30	Chrome
P562575	ABB-10-3S	3" STAINLESS BASKET	10	30	Chrome
P562576	ABB-10-3S-LT	3" STAINLESS BASKET, LOCK TAB	10	30	Chrome
P562577	ABB-10-3S-R	3" STAINLESS BASKET, BUNA GASKET	10	30	Chrome
P562578	ABB-10-3S-SMB	3" STAINLESS BASKET, SIDE MOUNT KIT	10	30	Chrome
P562579	ABB-10-6S	6" STAINLESS BASKET	10	30	Chrome
P562580	ABB-10-6S-LT	6" STAINLESS BASKET, LOCK TAB	10	30	Chrome
P562581	ABB-10-6S-R	6" STAINLESS BASKET, BUNA GASKET	10	30	Chrome
P562582	ABB-10-8S	8" STAINLESS BASKET	10	30	Chrome
P562583	ABB-10-8S-D-IG	8" STAINLESS BASKET, DIPSTICK, INNER GUARD	10	30	Chrome
P562584	ABB-10-N	NYLON BASKET	10	30	Chrome
P562585	ABB-10-N-LT	NYLON BASKET, LOCK TAB	10	30	Chrome
P562587	ABB-10-N-R	NYLON BASKET, BUNA GASKET	10	30	Chrome
P562589	ABB-40	FLANGE, SCREWS & GASKET, NO BASKET	40	30	Chrome
P562590	ABB-40-3S	3" STAINLESS BASKET	40	30	Chrome
P562591	ABB-40-3S-LT	3" STAINLESS BASKET, LOCK TAB	40	30	Chrome
P562592	ABB-40-3S-R	3" STAINLESS BASKET, BUNA GASKET	40	30	Chrome
P562593	ABB-40-3S-SMB	3" STAINLESS BASKET, SIDE MOUNT KIT	40	30	Chrome
P562594	ABB-40-6S	6" STAINLESS BASKET	40	30	Chrome
P562595	ABB-40-6S-D	6" STAINLESS BASKET, DIPSTICK	40	30	Chrome
P562596	ABB-40-6S-LT	6" STAINLESS BASKET, LOCK TAB	40	30	Chrome
P562597	ABB-40-6S-R	6" STAINLESS BASKET, BUNA GASKET	40	30	Chrome
P562598	ABB-40-8S	8" STAINLESS BASKET	40	30	Chrome
P562599	ABB-40-8S-D	8" STAINLESS BASKET, DIPSTICK	40	30	Chrome
P562600	ABB-40-8S-LT	8" STAINLESS BASKET, LOCK TAB	40	30	Chrome
P562601	ABB-40-CWOF	CAP ONLY	40	30	Chrome
P562602	ABB-40-LT	LOCK TAB, NO BASKET	40	30	Chrome
P562603	ABB-40-N	NYLON BASKET	40	30	Chrome
P562605	ABB-40-N-LT	NYLON BASKET, LOCK TAB	40	30	Chrome
P562606	ABB-40-N-LT-R	NYLON BASKET, LOCK TAB, BUNA GASKET	40	30	Chrome
P562608	ABB-40-N-R	NYLON BASKET, BUNA GASKET	40	30	Chrome
P562609	ABB-40-N-SMB	NYLON BASKET, SIDE MOUNT KIT	40	30	Chrome

# Vc PUMP MOUNTS for NEMA FRAME ELECTRICAL MOTORS



MOTOR SIZE	56C	143TC	145TC
HP/1800 RPM	1/4-1/2	1	2
SHAFT DIAMETER	.625	.875	.875
KEY SIZE	3/16	3/16	3/16
SHAFT LENGTH	2.063	2.125	2.125

MOTOR SIZE	182UC	184UC
HP/1800 RPM	1	1-1/2
SHAFT DIAMETER	.875	.875
KEY SIZE	3/16	3/16

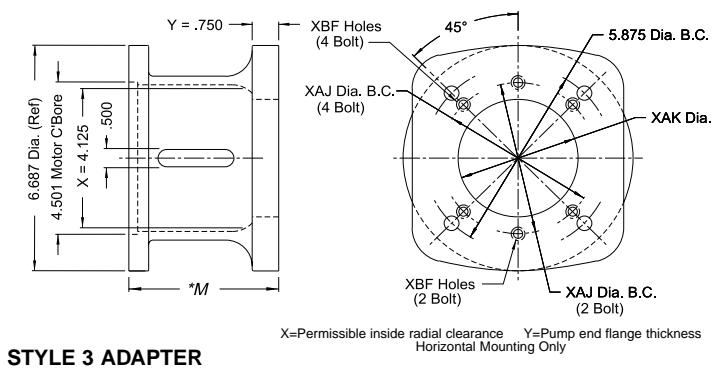
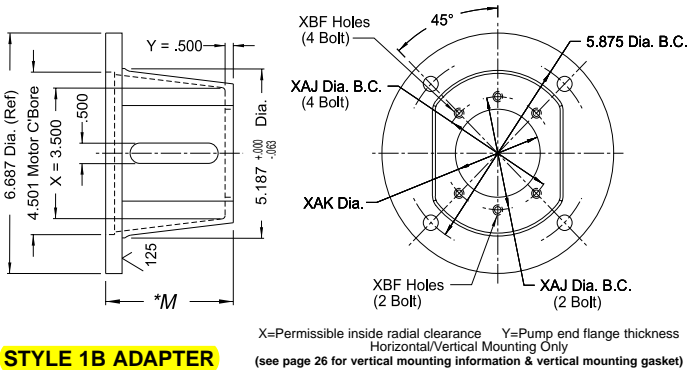
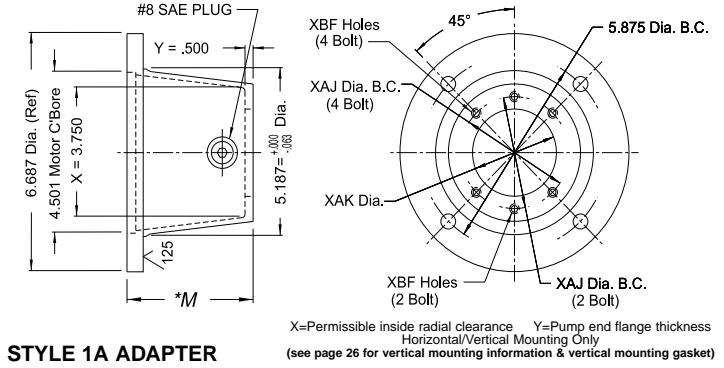
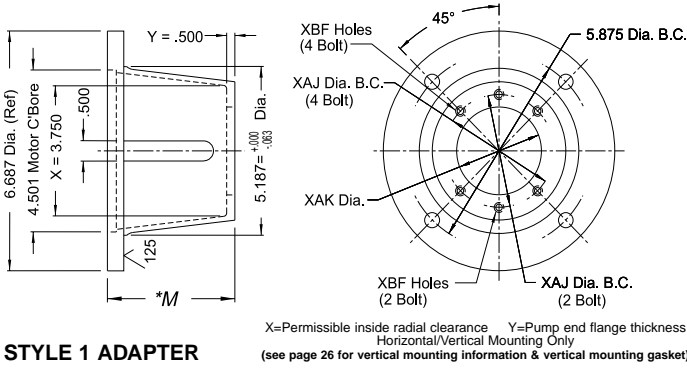

If your pump is not listed or is a non-standard pump, contact us for special machining and/or information.  
Most models listed also available in dampened design. Consult factory for more information.

PUMP TYPE	FLANGE	XAJ BOLT CIRCLE	XAK PUMP PILOT	XBF MOUNTING HOLES	ADAPTER STYLE	MOUNTING HORIZ / VERT	FACE TO FACE	VESCOR PART NUMBER
-----------	--------	-----------------	----------------	--------------------	---------------	-----------------------	--------------	--------------------

## STANDARD SAE PUMP FLANGES

USA 4F17	4 Bolt	2.84	1.781	5/16-18	1	yes	yes	3.50	170599
					1A	yes	yes	3.50	6094
					1B	yes	yes	3.81	152199
					1	yes	yes	4.25	6029
					1A	yes	yes	4.25	6070
					1B	yes	yes	4.50	150199
					1	yes	yes	5.06	171399
					1B	yes	yes	5.25	150799



PUMP TYPE	FLANGE	XAJ BOLT CIRCLE	XAK PUMP PILOT	XBF MOUNTING HOLES	ADAPTER STYLE	MOUNTING HORIZ / VERT		FACE TO FACE	VESCOR PART NUMBER	
<b>STANDARD SAE PUMP FLANGES</b>										
1	SAE AA	2 Bolt	3.25	2.001	3/8-16	1	yes	yes	3.50	<b>170699</b>
						1A	yes	yes	3.50	<b>6093</b>
						1B	yes	yes	3.81	<b>152299</b>
						1	yes	yes	4.25	<b>6027</b>
						1A	yes	yes	4.25	<b>6095</b>
						B	yes	yes	4.50	<b>150299</b>
						1	yes	yes	5.06	<b>171499</b>
						1B	yes	yes	5.25	<b>150699</b>
SAE A	2 Bolt	4.19	3.251	3/8-16	1A	yes	yes	3.50	<b>6091</b>	
					1A	yes	yes	4.25	<b>6071</b>	
1	SAE A	2 Bolt	4.19	3.251	3/8-16	1	yes	yes	3.50	<b>170799</b>
						B	yes	yes	3.81	<b>152399</b>
						1	yes	yes	4.25	<b>6028</b>
						1B	yes	yes	4.50	<b>150499</b>
						1	yes	yes	5.06	<b>6042</b>
						1B	yes	yes	5.25	<b>150599</b>
SAE B	2 Bolt 4 Bolt	5.75 5.00	4.001	1/2-13	3	yes	no	4.25	<b>149199</b>	
					3	yes	no	5.06	<b>149799</b>	
					3	yes	no	5.63	<b>6085</b>	
SAE C	4 Bolt	6.375	5.001	1/2-13	3	yes	no	5.63	<b>6074</b>	
<b>2 BOLT SPECIAL MOUNTING FLANGE</b>										
2H	2 Bolt	4.19	2.001	3/8-16	1	yes	yes	4.25	<b>6072</b>	
<b>3 BOLT MOUNTING FLANGE</b>										
3H	3 Bolt	2.75	2.121	1/4-20	1	yes	yes	4.25	<b>6062</b>	
<b>SAE 4 BOLT MOUNTING FLANGE (MODIFIED)</b>										
4BM	4 Bolt	5.00	4.001	3/8-16	3	yes	no	4.25	<b>142199</b>	
					3	yes	no	5.06	<b>142299</b>	
					3	yes	no	5.63	<b>142399</b>	



# STANDARD BORE and KEYWAY CHART

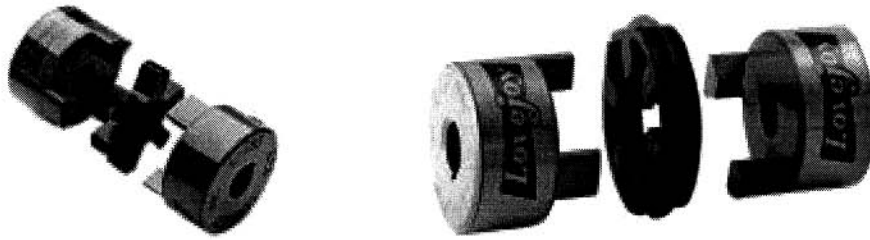

**L Type Inch Hubs Standard Bore and Keyway Chart**

BORE	KEYWAY	L035	L050	L070	L075	L090	L095	L099	L100	L110	L150	L190	L225	L276
1/8	No KW	10124												
3/16	No KW	10126												
1/4	No KW	10127	10206	10416	10680	10766								
1/4	1/8x1/16				35744									
5/16	No KW	10128	10207	10417	10681	26209								
3/8	No KW	24687	10208	10418	10682	10767								
3/8	3/32x3/64		46121	41985	37234	37235								
3/8	1/8x1/16		44136	48829	35745	37236								
7/16	No KW		10209	10419	10683	10768	11082	31297	11505					
7/16	3/32x3/64		44713	44007	28089	28877	27613	38198	37237					
7/16	1/8x1/16		44066	28875	28878	28878	28879	38199	37238					
1/2	No KW		10210	10420	10684	10769	11083	11333	11506					
1/2	1/8x1/16		10211	10421	10685	26087	26088	11334	26089					
9/16	No KW		10212	52338	10686	24976	37239	11335	11508					
9/16	1/8x1/16		10213	10423	10687	28876	11084	38200	11509					
5/8	No KW		10214	24771	44322	46052	41911	44174	44291	11733	12101			
5/8	5/32x5/64			51104	37240	37241	37242	38201	37243	37244	37245			
5/8	3/16x3/32			10424	10688	10771	11085	11336	11510	26211	26212			
11/16	3/16x3/32			10425	10689	10772	11086	11337	11511	11734	12102			
3/4	No KW			46116	56140	54282	56887	11455	45212			12285	12422	
3/4	1/8x1/16			51719	35881	37246	37074	38202	37247	37248	37249	37250		
3/4	3/16x3/32			10426	10690	10773	11087	11338	11512	11735	12103	38468	35882	
13/16	3/16x3/32				10691	10774	11088	11339	11513	11736	12104	37252	37255	
7/8	No KW				56941			59063						12582
7/8	3/16x3/32				10692	10775	11089	11340	11514	11737	12105	12286	12423	12585
7/8	1/4x1/8					38188	35747	38203	35686	35749	35750	37256	35753	54833
15/16	1/4x1/8					32332	11090	11341	11515	11738	12106	12287	12424	
1	1/4x1/8					31296	11091	11342	11516	11739	12107	12288	12425	12586
1	3/16x3/32					37257	37258	38204	37259	37260	37261	37262	37263	
1-1/16	1/4x1/8						11092	11343	11517	11740	12108	12289	12426	
1-1/8	1/4x1/8						11093	11344	11518	11741	12109	12290	12427	12587
1-3/16	1/4x1/8							11345	11519	11742	12110	12291	12428	
1-1/4	1/4x1/8								11520	11743	12111	12292	12429	12588
1-1/4	5/16x5/32								35748	35752	35751	37264	35754	12589
1-5/16	5/16x5/32								11521	11744	12112	12293	26090	
1-3/8	5/16x5/32								11522	11745	12113	12294	12430	12590
1-3/8	3/8x3/16								44348	37265	37266	37267	37268	46758
1-7/16	3/8x3/16									11746	12144	12295	12431	12591
1-1/2	5/16x5/32									37269	37270	37271	37272	
1-1/2	3/8x3/16									11747	12115	12296	12432	12592
1-9/16	3/8x3/16									11748	12116	37273	12433	45689
1-5/8	3/8x3/16									11749	12117	12297	12434	12593
1-11/16	3/8x3/16										12118	12298	12435	60057
1-3/4	3/8x3/16										12119	12299	12436	12594
1-3/4	7/16x7/32										37274	37275	37276	48250
1-13/16	1/2x1/4										12120	12300	26091	
1-7/8	1/2x1/4										12121	12301	12437	12595
1-15/16	1/2x1/4											12302	12438	49762
2	1/2x1/4											12303	12439	12596
2-1/16	1/2x1/4											12304	26092	
2-1/8	1/2x1/4											12305	12440	12597
2-3/16	1/2x1/4												12441	12598
2-1/4	1/2x1/4												12442	12599
2-3/8	5/8x5/16												12443	12602
2-5/8	5/8x5/16												41809	12605
2-7/8	3/4x3/8													12607

NOTE: All finished bore hubs are provided with one set screw as standard. Non-standard bores available, consult engineering.

# Single and Double Vane Pumps

**Model Series V10, V20, V2010, and V2020  
for Industrial Equipment**

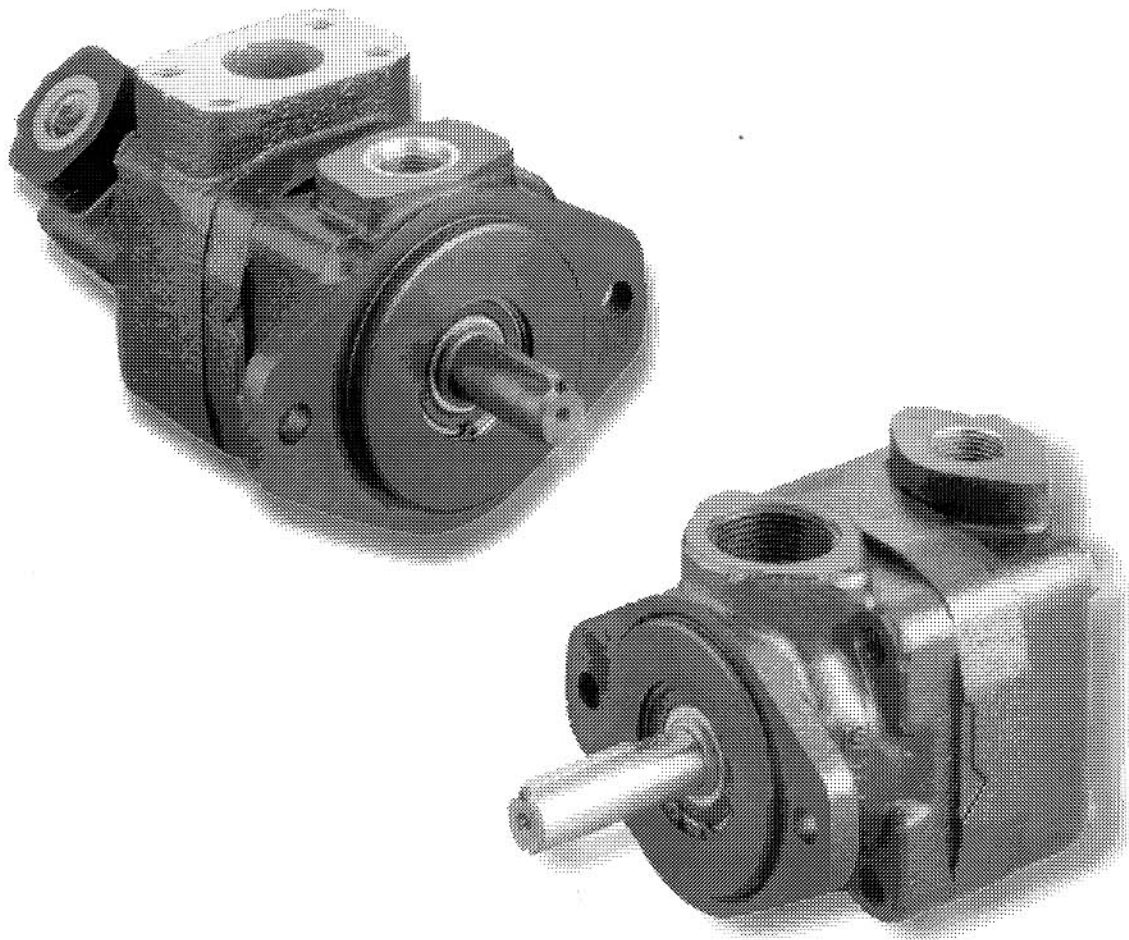





# Basic Performance Data – Single and Double Pumps

## Typical operating characteristics at 1200 r/min with petroleum oil

Ring size		Data based on performance at oil temperature of 49° C (120° F), viscosity 32 cSt at 38° C (150 SUS at 100° F)							
		7 bar (100 psi)		69 bar (1000 psi)		138 bar (2000 psi)		155 bar (2250 psi)	
V10 single pump †	V20 single pump ‡	Lpm (USgpm)	Input kW (hp)	Lpm (USgpm)	Input kW (hp)	Lpm (USgpm)	Input kW (hp)	Lpm (USgpm)	Input kW (hp)
1	–	3,8 (1)	0,2 (.3)	2,7 (.7)	0,5 (.8)	2,5 (.65)	1 (1.4)	2,3 (.6)	1,2 (1.6)
2	–	7,6 (2)	0,2 (.3)	6,8 (1.8)	1,3 (1.75)	6,4 (1.7)	2,2 (3)	6 (1.6)	2,8 (3.8)
3	–	11,4 (3)	0,3 (.4)	10,6 (2.8)	1,6 (2.2)	10,2 (2.7)	3,3 (4.4)	9,8 (2.6)	3,7 (5)
4	–	15,1 (4)	0,3 (.4)	14 (3.7)	2,2 (3)	13,6 (3.6)	4,3 (5.8)	13,2 (3.5)	4,8 (6.5)
5	–	18,9 (5)	0,4 (.6)	18,2 (4.8)	2,7 (3.6)	17,4 (4.6)	5,2 (7)	17 (4.5)	5,8 (7.8)
6	–	23,1 (6.1)	0,7 (.9)	21,6 (5.7)	3,7 (5)	20,4 (5.4)	6,7 (9)	20,1 (5.3)	7,5 (10)
7	–	27,2 (7.2)	0,7 (1)	25,7 (6.8)	4,1 (5.5)	24,6 (6.5)	7,8 (10.4)	23,8 (6.3)	8,7 (11.6)
–	6	23,5 (6.2)	0,9 (1.25)	20,1 (5.3)	3,6 (4.9)	19,7 (5.2)	6,3 (8.4)	19,3 (5.1)	7,5 (10)
–	7	26,9 (7.1)	0,9 (1.25)	25 (6.6)	3,7 (5)	23,5 (6.2)	6,9 (9.2)	23,1 (6.1)	8,6 (11.5)
–	8	31 (8.2)	0,9 (1.25)	28,8 (7.6)	4,2 (5.6)	27,2 (7.2)	8,1 (10.9)	26,9 (7.1)	10,4 (14)
–	9	34,8 (9.2)	1 (1.3)	32,6 (8.6)	4,6 (6.2)	31 (8.2)	9 (12.1)	30,7 (8.1)	11,9 (16)
–	11	43,5 (11.5)	1 (1.3)	37,8 (11)	5,7 (7.6)	39,7 (10.5)	10,9 (14.6)	39,4 (10.4)	13 (17.5)
–	12	45,4 (12)	1 (1.3)	43,2 (11.4)	6,1 (8.2)	40,9 (10.8)	11,6 (15.6)	–	–
–	13	51,1(13.5)	1 (1.3)	49,2 (13)	6,6 (8.8)	47,3 (12.5)	12,4 (16.7)	–	–

† Also cover-end ring of V2010 double pump .

‡ Also shaft-end ring of V2010 and V2020 double pumps, and cover-end ring (except sizes 12 & 13) of V2020 double pump.

NOTE: See curves for complete operating characteristics with petroleum oil. [Click here for single pumps.](#) [Click here for double pumps.](#)

## Maximum speeds & pressures using fire-resistant fluids

Ring size	Maximum speed by fluid type – r/min		Maximum pressure by fluid type – bar (psi)		
	Water-glycol and water-in-oil emulsion	Synthetic fluid	Water glycol	Water-in-oil emulsion	Synthetic fluid
1, 2, 3, 4, 5	1800	1800	124 (1800)	103 (1500)	138 (2000)
6, 7, 8, 9	1800	1800	124 (1800)	109 (1575)	138 (2000)
11	1800	1500	109 (1575)	93 (1350)	138 (2000)
12,13	1800	1500	109 (1575)	93 (1350)	124 (1800)

NOTE: 3 inches of Hg is the maximum inlet vacuum for the maximum speeds above. [Click here for complete application details.](#)

## Speed rating per inlet condition

Maximum operating speeds shown on performance curves are for pumps operating at 0 psi inlet condition. To compute maximum operating speeds at other inlet conditions, use appropriate speed rating correction factor shown on the curve on the right.

Example:

Max. speed @ 0 psi inlet 2800 rpm

Correction factor @ 5 in. Hg x .93

Max. speed @ 5 in. Hg inlet 2604 rpm

Pump inlet suction should not exceed 5 in. Hg vacuum for petroleum oil or 3 in. Hg vacuum for other fluid types. Positive pressure on inlet should not exceed 10 psi.

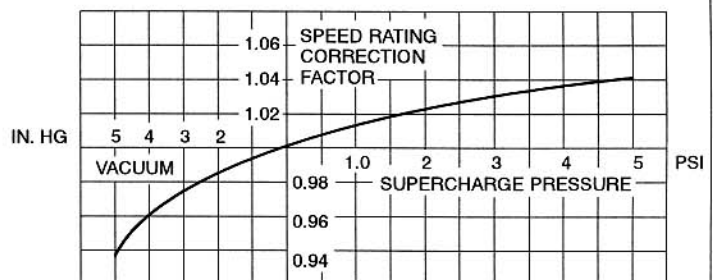



# Single Pumps

## Model Codes

**F3 - V 10 - 1 P 5 S - 1 C 20 L**

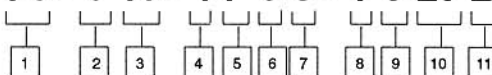

### 1 Special Seals

Omit if not required.

[Click here for information on seals.](#)

### 2 Vane pump

### 3 Series

10 or 20

### 4 Mounting

1 - 2-bolt flange, 3.25" pilot (standard)  
6 - 2-bolt flange, 4.00" pilot (optional)

[Click here to see optional foot bracket kits.](#)

### 5 Inlet port connections

P - 1" NPT thread (V10 only)  
1 1/4" NPT thread (V20 only)  
S - 1.3125-12 straight thread (V10 only)  
1.625-12 straight thread (V20 only)

### 6 Ring size

(Delivery at 1200 r/min and 100 psi)

1 - 1 USgpm  
2 - 2 USgpm  
3 - 3 USgpm  
4 - 4 USgpm  
5 - 5 USgpm  
6 - 6 USgpm  
7 - 7 USgpm

V10 series

6 - 6 USgpm  
7 - 7 USgpm  
8 - 8 USgpm  
9 - 9 USgpm  
11 - 11 USgpm  
12 - 12 USgpm  
13 - 13 USgpm

V20 series\*

### 7 Outlet port connections

P - 1/2" NPT thd. (V10)  
3/4" NPT thd. (V20)  
R - 1.1875-12 St. thd. (V20 only)  
S - .750-16 St. thd. (V10 only)  
1.0625-12 St. thd. (V20 only)

### 8 Shafts

1 - Straight keyed  
11 - Splined  
38 - 11 Tooth - 3/4" OD  
62 - Splined (V20 only)

### 9 Position of outlet port

(Viewed from cover end of pump)

A - Opposite inlet port  
B - 90° CCW from inlet  
C - In line with inlet  
D - 90° CW from inlet

### 10 Design

11 - V20 series  
20 - V10 series  
Subject to change.

### 11 Shaft rotation

(Viewed from shaft end of pump)  
L - Left hand (counterclockwise).  
Omit for right hand.

## Specifications

Based on using petroleum oil at 49° C (120° F), viscosity 32 cSt at 38° C (150 SUS at 100° F), and 0 psi inlet pressure

Model series	Ring size (Delivery USgpm @ 1200 r/min & 100 psi)	Displ. cm <sup>3</sup> /r (in <sup>3</sup> /r)	Max. speed r/min	Maximum pressure bar (psi)	Typical delivery L/min (USgpm) @ max. speed & pressure	Typical input power kW (hp) @ max. speed & pressure	Weight kg (lb)
V10	1	3,3 (.20)	4800	172 (2500)	13,6 (3.6)	5,2 (7)	4,5 - 6,8 (10 - 15)
	2	6,6 (.40)	4500	172 (2500)	27,6 (7.3)	10,1 (13.6)	
	3	9,8 (.60)	4000	172 (2500)	35,6 (9.4)	13,3 (17.8)	
	4	13,1 (.80)	3400	172 (2500)	41,3 (10.9)	15,2 (20.4)	
	5	16,4 (1.00)	3200	172 (2500)	48,5 (12.8)	17 (22.8)	
	6	19,5 (1.19)	3000	152 (2200)	55,3 (14.6)	18,3 (24.5)	
	7	22,8 (1.39)	2800	138 (2000)	60,6 (16)	17,9 (24)	
V20	6	19,5 (1.19)	3400	172 (2500)	60,9 (16.1)	21,6 (29)	7,3 - 8,2 (16 - 18)
	7	22,8 (1.39)	3000	172 (2500)	63,2 (16.7)	22 (29.5)	
	8	26,5 (1.62)	2800	172 (2500)	67 (17.7)	24,2 (32.5)	
	9	29,7 (1.81)	2800	172 (2500)	75 (19.8)	26,5 (35.5)	
	11	36,4 (2.22)	2500	172 (2500)	86,7 (22.9)	28 (37.5)	
	12	39 (2.38)	2400	152 (2200)	87,1 (23)	26,8 (36)	
	13	42,4 (2.59)	2400	152 (2200)	98 (25.9)	29,1 (39)	

[Click here to see speed correction curve.](#)



# Single Pumps

## V10 Performance

Oil temp. 49°C (120°F), viscosity  
32 cSt (150 SUS) @ 38°C (100°F),  
inlet pressure zero

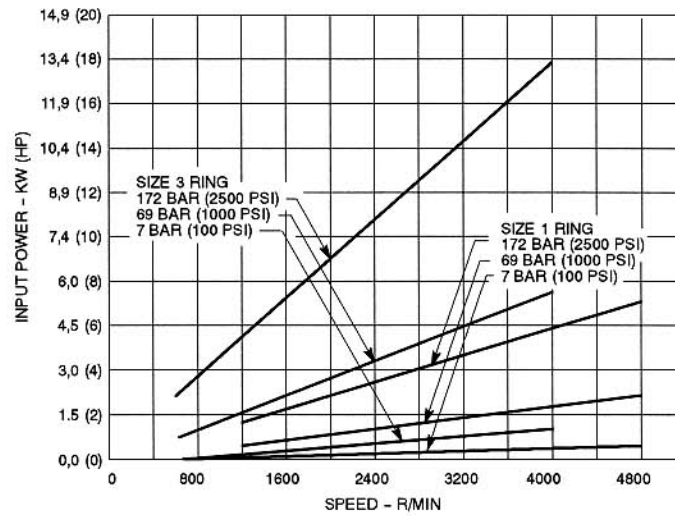
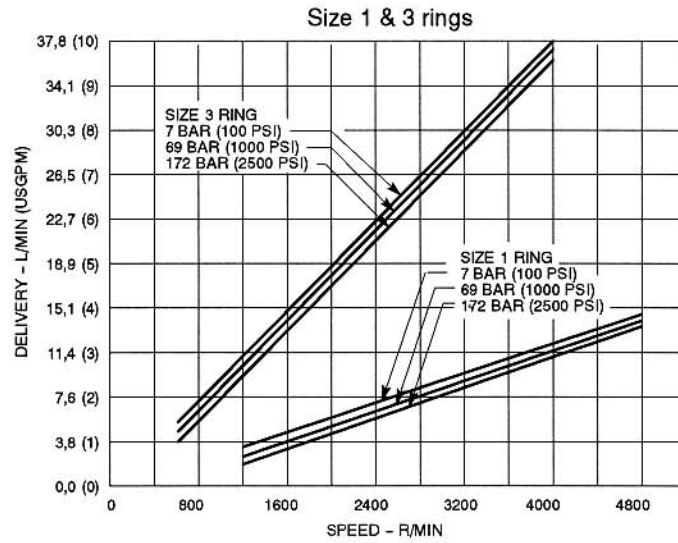



# Single Pumps

## V10 Performance

Oil temp. 49°C (120°F), viscosity  
32 cSt (150 SUS) @ 38°C (100°F),  
inlet pressure zero

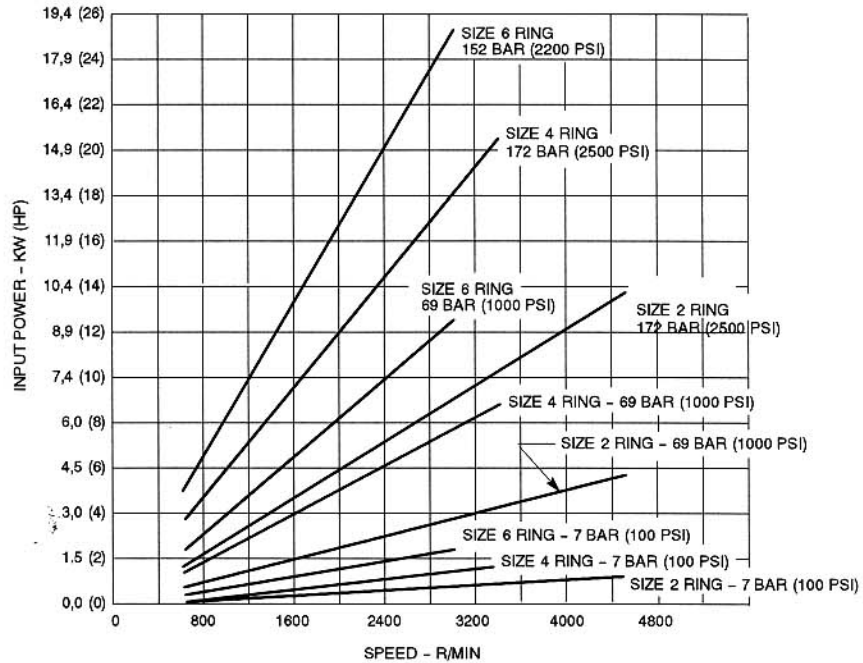
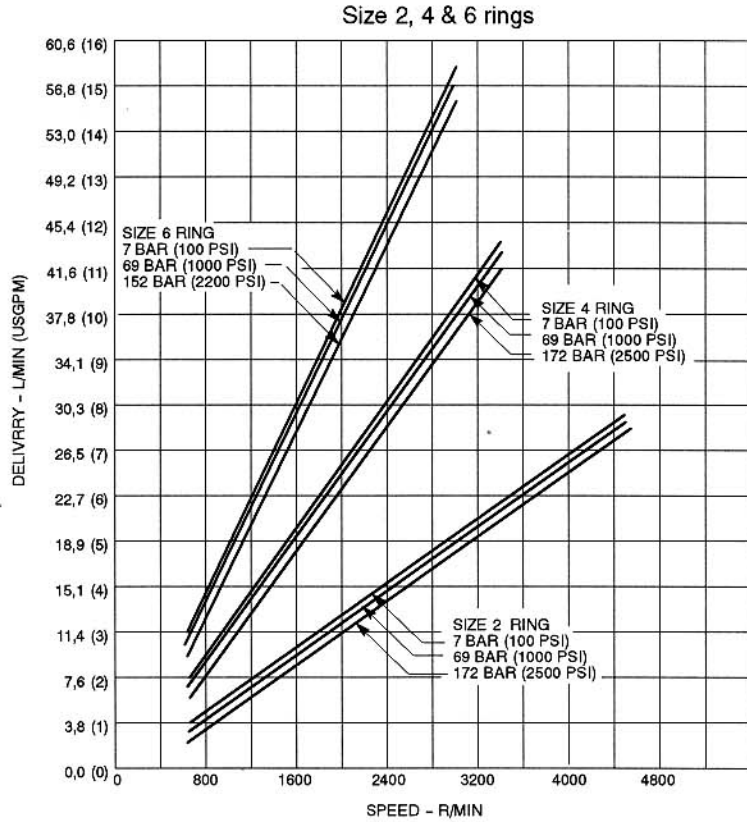



# Single Pumps

Size 5 & 7 rings

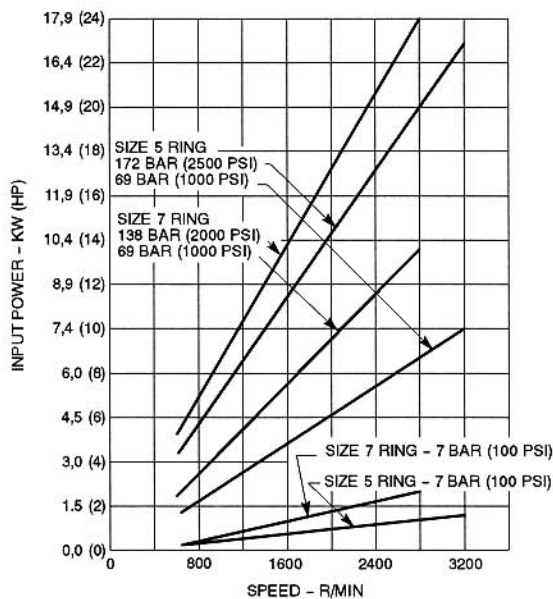
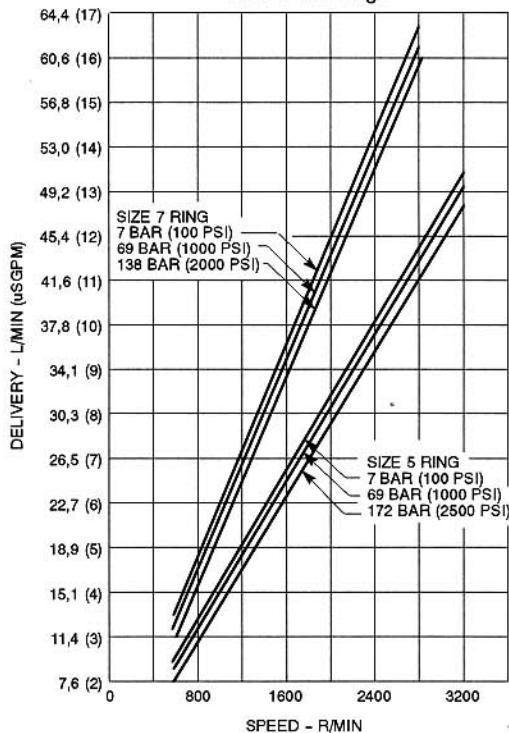



# Single Pumps

## V10 Dimensions

### Millimeters (inches)

Click here to see foot mounting dimensions.

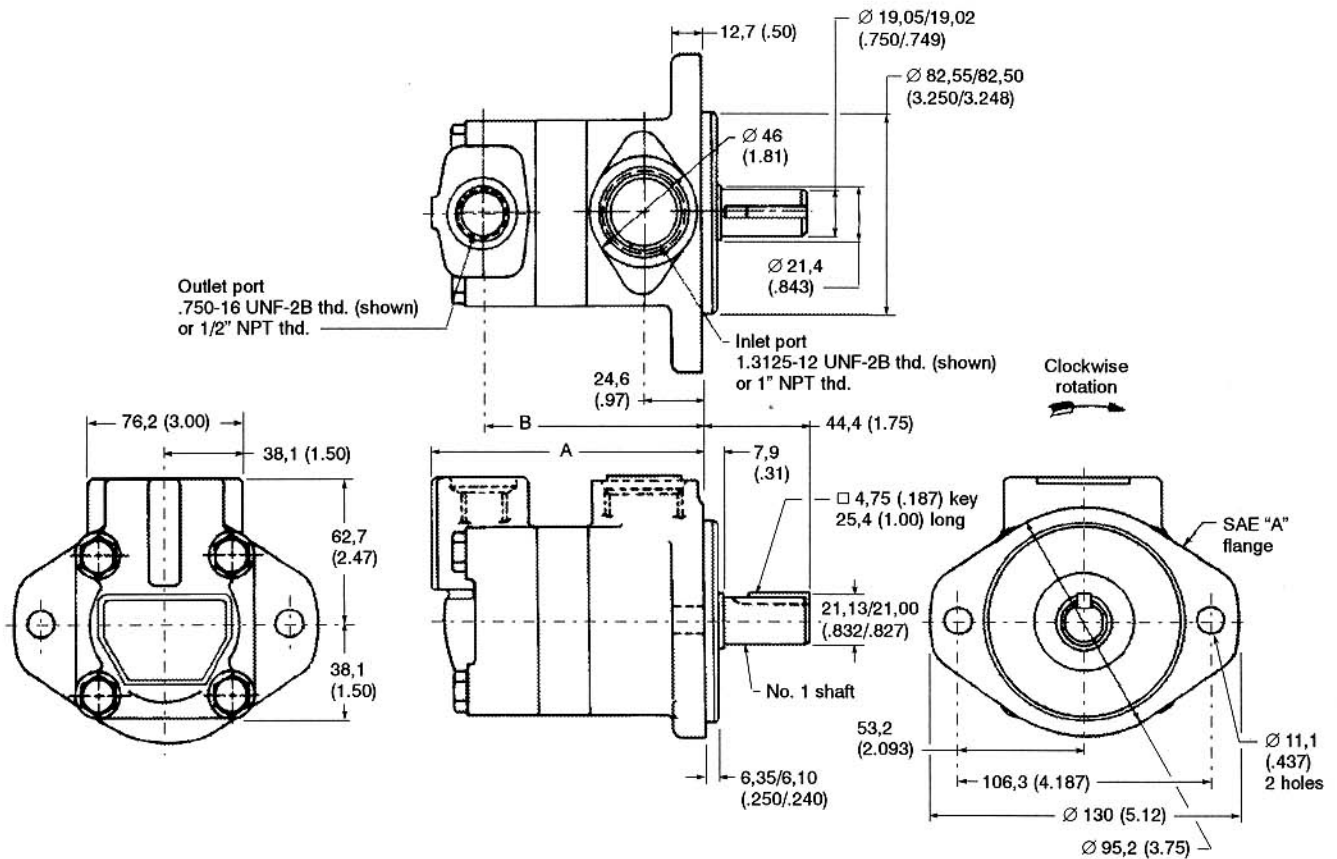

Number 11 shaft

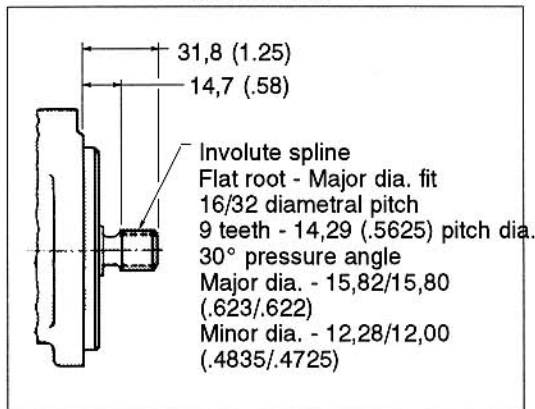

Ring size	Dimension	
	A	B
1	115,6 (4.55)	91,9 (3.62)
2	115,6 (4.55)	91,9 (3.62)
3	115,6 (4.55)	91,9 (3.62)
4	121,9 (4.80)	98,3 (3.87)
5	121,9 (4.80)	98,3 (3.87)
6	127,0 (5.00)	103,4 (4.07)
7	127,0 (5.00)	103,4 (4.07)



# Application and Service Information

## Minimum Speed

Minimum recommended starting speed is generally 600 r/min. However, the pump size, system characteristics and environmental conditions can raise or lower this speed. A lower speed can often be achieved after the pump has primed.

If low starting or operating speeds are required, consult your Vickers representative.

## Inlet Pressure

Recommended inlet pressure is 0 to 0,34 bar (0 to 5 psi) gauge at maximum operating speeds. Inlet pressure should not exceed 0,69 bar (10 psi). Inlet depressions should not exceed 5 inches of Hg with petroleum oil, or 3 inches of Hg with all other fluids.

A pressurized reservoir system does not always assure a positive (supercharge) pressure at the pump inlet. Vacuum at the pump inlet can result during cold start-ups. Avoid high speeds until the circuit has warmed and supercharge pressure actually exists at the pump inlet.

## Drives

Vickers pumps are designed for use on direct coaxial drives. If drives imposing radial or axial loads are being considered, consult your Vickers representative for additional information.

Concentricity and angular alignment of shafts are important to pump life. Misalignment can induce heavy loads on bearings, causing premature failure.

Flexible coupling halves must be aligned according to the coupling manufacturer's recommendations.

When using double universal joint couplings, the shafts must be parallel and the yokes must be in line. The offset should be kept as low as possible. Maximum allowable offset will, of course, vary with application conditions. The pump shaft to universal joint diametral fit should be close (major diameter fit) with no looseness.

## Mounting Dimensions

Concentricity of the customer's female pilot diameter relative to the effective axis of the female drive must be within 0,10 mm (.004 in.) total indicator reading. The clearance between the male and female pilot diameters must be +0,01 to +0,05 mm (+.0005 to +.0020 in.).

The customer's mounting face to which the pump is affixed must be square to the axis of the female drive within 0,04 mm per mm (.0015 in. per in.).

Dimensions of the customer's keyed shaft receiver must be between +0,003 and +0,025 mm (+.0001 and +.0010 in.) of the maximum shaft diameter shown on the Vickers installation drawing.

## Valves and Circuitry

Protect against hydraulic surge pressures (inlet or outlet) applied to or generated by the pump. Relief valves must prevent these surges from exceeding published pressure ratings.

Never assume a relief valve setting is the maximum pressure a pump experiences. Shock conditions may exist which can exceed circuit and pump limitations.

## Shaft Loading

Never assume pumps in a double pump assembly can be simultaneously loaded to rated pressure. Shaft loading must be checked for excessive torque and side loads.

## Piping

Hydraulic lines should be as short and have as large an inside diameter as possible. Where lines are long, it is desirable to adapt to a larger capacity line than a unit's ports specify. Inlet, outlet and drain lines should not be smaller than the nominal port size shown on installation drawings. A "Y" shaped inlet should not be used to feed two separate pumps because one may be starved and cavitate.

There should be as few bends and fittings in lines as possible. High-pressure lines and fittings are restrictive to flow and may result in excessive pressure drop through the system. They should be used only where necessary in a pressure line.

## Hose

When installing a hose, allow enough slack to avoid kinking. A taut hose will not allow movement with pressure surges. Slack in the line compensates for surges, relieving strain. The hose should not be twisted during installation or while in operation. Twisting will weaken the hose and loosen connections.

A neater installation is usually obtainable by using extra fittings to minimize unusually long loops in a line. Hoses should be clamped to prevent rubbing and entanglement with moving parts. Where hoses are subject to chafing, they should be run through protective neoprene hose or shielded metallic guards.



# Application and Service Information

## Hydraulic Fluids

Pumps can be used with anti-wear hydraulic oil, or automotive type crankcase oil (designations SC, SD, SE, SF, or SG) per SAE J183 JUN89. Fire-resistant fluids can also be used, but may require the use of special seals as explained in the following "Seals" section.

The viscosity range of petroleum oil, with the pump running, should be 13-54 cSt (70-250 SUS). The oil viscosity at 38°C (100°F) should be 32-48 cSt (150-225 SUS).

Fire-resistant fluids should have a viscosity as close as possible to that of petroleum oil as described above. A maximum specific gravity of 1.3 is suggested for fire-resistant fluids.

An operating temperature of 49°C (120°F) is recommended. The maximum temperature for oil should be 65°C (150°F), and the maximum for water-containing fluids should be 130°F.

For additional fluid and temperature information, refer to Vickers data sheet I-286-S.

## Seals

Nitrile seals are standard and are suitable for use with petroleum, water-glycol, water-in-oil emulsion, polyol ester, and high-water-base fluids. Phosphate ester fluids require the use of fluorocarbon seals, which are identified in model codes as an "F3" prefix.

## Fluid Cleanliness

Proper fluid condition is essential for long and satisfactory life of hydraulic components and systems. Hydraulic fluid must have the correct balance of cleanliness, materials and additives for protection against wear of components, elevated viscosity and inclusion of air.

Essential information on the correct methods for treating hydraulic fluid is included in Vickers publication 561; "Vickers Guide to Systemic Contamination Control," available from your local Vickers distributor or by contacting Vickers, Incorporated. Recommendations on filtration and the selection of products to control fluid condition are included in 561.

Recommended cleanliness levels, using petroleum oil under common conditions, are based on the highest fluid pressure levels in the system and are coded in the chart below. Fluids other than petroleum, severe service cycles, or personnel safety considerations are cause for adjustment of these cleanliness codes. See Vickers publication 561 for exact details

Vickers products, as any components, will operate with apparent satisfaction in fluids with higher cleanliness codes than those described. Other manufacturers will often recommend levels above those specified. Experience has shown, however, that life of any hydraulic components is shortened in fluids with higher cleanliness codes than those listed below. These codes have been proven to provide a long trouble-free service life for the products shown, regardless of the manufacturer.

Product	System Pressure Level – bar (psi)		
	<70 (<1000)	70-210 (1000-3000)	210+ (3000+)
Vane Pumps – Fixed	20/18/15	19/17/14	18/16/13
Vane Pumps – Variable	18/16/14	17/15/13	
Piston Pumps – Fixed	19/17/15	18/16/14	17/15/13
Piston Pumps – Variable	18/16/14	17/15/13	16/14/12
Directional Valves	20/18/15	20/18/15	19/17/14
Pressure/Flow Control Valves	19/17/14	19/17/14	19/17/14
CMX Valves	18/16/14	18/16/14	17/15/13
Servo Valves	16/14/11	16/14/11	15/13/10
Proportional Valves	17/15/12	17/15/12	15/13/11
Cylinders	20/18/15	20/18/15	20/18/15
Vane Motors	20/18/15	19/17/14	18/16/13
Axial Piston Motors	19/17/14	18/16/13	17/15/12
Radial Piston Motors	20/18/14	19/17/13	18/16/13





# Application and Service Information

## Aeration

Reservoir and circuit design must prevent aeration of the fluid. Particular care must be used to employ joints, seals and gaskets that will not leak or deteriorate. This is especially important in low pressure and suction lines. Connections should always be tight to prevent air from entering the system.

It is best to use windows and sight glasses in the reservoir and inlet lines during prototype evaluation to determine whether significant amounts of air are present in the fluid. Any opaqueness or milky appearance of the fluid in the lines or reservoir indicates excessive aeration. Bubbles on the surface of the reservoir fluid may indicate that excessive aeration is present.

## Reservoir

The oil level of the reservoir should be as high as possible above the pump suction line opening. All return lines should discharge near the tank bottom, always below the oil level, and as far from the pump inlet as possible.

Reservoirs should incorporate a sight gauge, dipstick or other means for easy checking of the oil level. Without these devices, the oil level often goes unchecked and, should a leak occur, the pump can be starved and damaged from loss of lubrication.

Preferably, reservoirs should be located above pumps. This creates a flooded pump inlet which reduces the possibility of pump cavitation.

Pump suction and tank return lines should be attached to the reservoir by flanges or welded heavy-duty coupling. If the suction line is connected to the bottom of the reservoir, the coupling should extend above the bottom inside the tank. This prevents residual dirt from getting into the suction line when the tank is cleaned. The seals used on all suction line connections should be such that they will not deteriorate and leak.

A baffle plate in the reservoir is desirable to separate the suction and return lines. The plate causes return oil to circulate around the outer wall of the reservoir for cooling before it re-enters the pump. It also helps provide time for entrained air to separate from the oil. Baffle plate openings should be designed so that cascade effects and resultant air entrainment are minimized.

Most reservoirs are vented to the atmosphere through an opening that lets air leave or enter the space above the oil as the oil level rises or falls. A filler/breather unit containing an air filtering element is often used as the vent. It must be large enough to handle the air flow required to maintain atmospheric pressure whether the tank is full or empty.

## Startup

Before starting, fill the pump with system fluid through the uppermost port. The housing must be kept full at all times to provide internal lubrication.

At initial startup, it may be necessary to bleed air from the pump outlet to permit priming and reduce noise. Bleed by loosening an outlet connection until a solid stream of fluid appears. An air bleed valve for this purpose is available through your Vickers representative.

## Application Guidance

To ensure optimum pump performance in conjunction with your specific application, consult your Vickers representative if your:

- Application requires an indirect drive
- Fluid does not meet specifications
- Mounting attitude is other than horizontal
- Oil viscosity at operating temperature is not within 13-54cSt (70-250 SUS)
- Oil viscosity at startup is in excess of 220 cSt (1000 SUS)
- Needs require application assistance

## Service Information

Refer to the following drawings for service parts information:

Model Series	Drawing
V10	M-2005-S
V20	M-2004-S
V2010	M-2255-S
V2020	M-2256-S

The overhaul manual for V10 and V20 models is I-3143-S.



# SS & MS SERIES INTERNALLY MOUNTED TANK FILTER

Port Sizes: 3/8" Thru 6" NPTF  
 Standard: 100 Mesh  
 Optional: 30, 60, & 200 Mesh

3 PSI (6" Hg) or 5 PSI (10" Hg) optional by-pass valve.

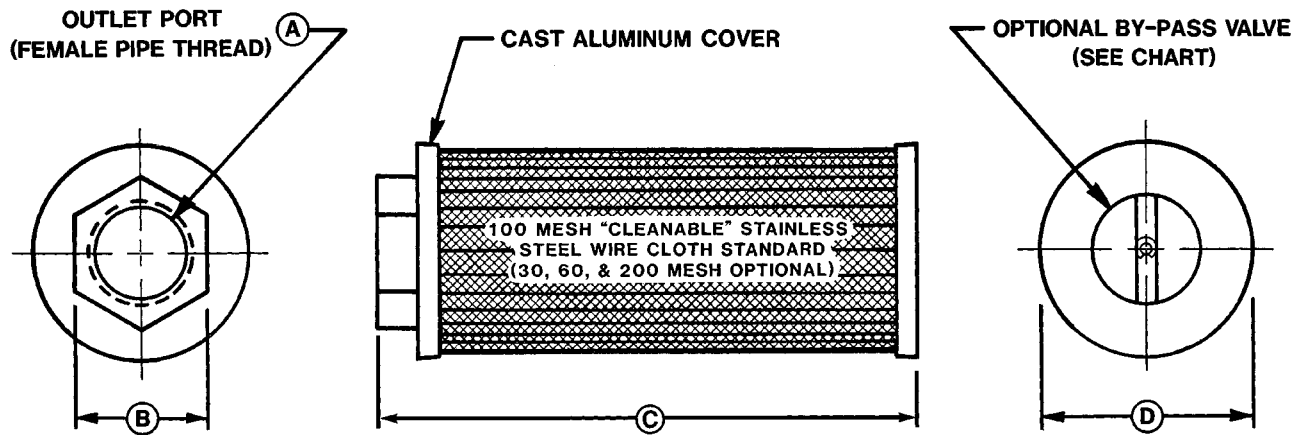

Model	A Outlet Port	B Wrench Flat	C Overall Length	D OD	Rated Flow At 5 Ft/Sec
MS-030-X-0*	3/8" NPTF	1.20"	2.6"	1.1"	3 GPM
SS-030-X-0*	3/8" NPTF	1.13"	2.2"	3.2"	3 GPM
MS-050-X-0*	1/2" NPTF	1.20"	2.6"	1.1"	5 GPM
SS-050-X-0*	1/2" NPTF	1.13"	2.2"	3.2"	5 GPM
MS-070-X-X	3/4" NPTF	1.50"	3.9"	1.5"	8 GPM
SS-070-X-X	3/4" NPTF	1.75"	3.6"	3.2"	8 GPM
MS-100-X-X	1" NPTF	1.75"	3.9"	1.7"	14 GPM
SS-100-X-X	1" NPTF	1.75"	4.6"	3.2"	14 GPM
SS-120-X-X	1 1/4" NPTF	2.25"	6.6"	3.2"	23 GPM
SS-150-X-X	1 1/2" NPTF	2.25"	8.6"	3.2"	32 GPM
SS-154-X-X	1 1/2" NPTF	2.25"	7.2"	4.2"	32 GPM
SS-200-X-X	2" NPTF	3.00"	7.2"	4.2"	53 GPM
SS-250-X-X	2 1/2" NPTF	3.50"	9.3"	4.2"	75 GPM
SS-300-X-X	3" NPTF	4.00"	12.4"	4.2"	116 GPM
SS-400-X-X	4" NPTF	NA	20.1"	9.0"	200 GPM
SS-600-X-X	6" NPTF	NA	20.1"	9.0"	450 GPM

**Design Features:**

- All MS, & SS Series models suitable for use with petroleum base oils, fire resistant hydraulic fluids, coolants, and lubricants.

**ZINGA EXCLUSIVE**

REVERSE TAPER

All Zinga Series tank filters have a reverse taper on the outside wall of the end caps. This ensures a positive interlock with the epoxy edge side. Thus preventing bond failure in rough terrain vehicle applications.

**HOW TO ORDER: XS-XXX - X - X**

Model

Code	Wire Mesh
0	100 Mesh (Std.)
2	200 Mesh
3	30 Mesh
6	60 Mesh

Code	By-Pass Valve
0	No Valve
3	3 PSI
5	5 PSI
*	By-Pass Valve Not Available On These Models

ALL TECHNICAL DATA DISCLOSED HEREIN IS UNCLASSIFIED AND IS NOT TO BE USED FOR MANUFACTURE, PROCUREMENT, OR DISCLOSURE TO OTHERS WITHOUT THE PRIOR WRITTEN AUTHORIZATION OF PREMIACH ENGINEERING LTD.

REV. NO.	DESCRIPTION OF CHANGE	BY	DATE

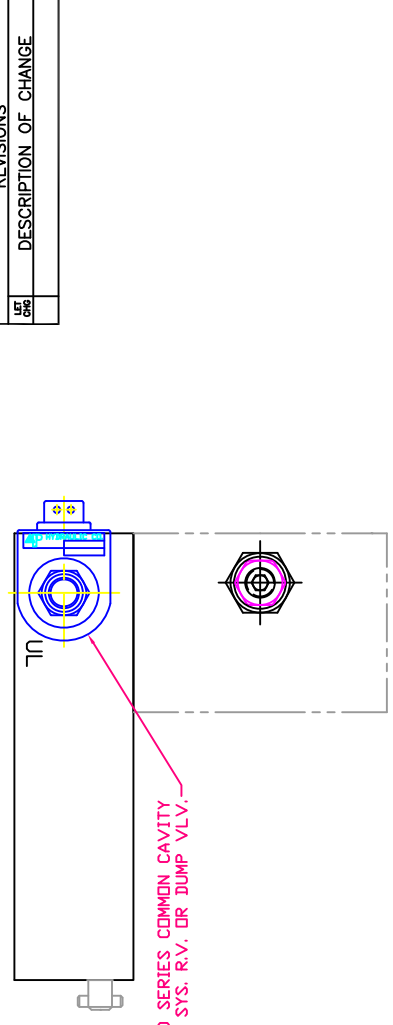

10 SERIES COMMON CAVITY FOR SYS. R.V. OR DUMP VLV.

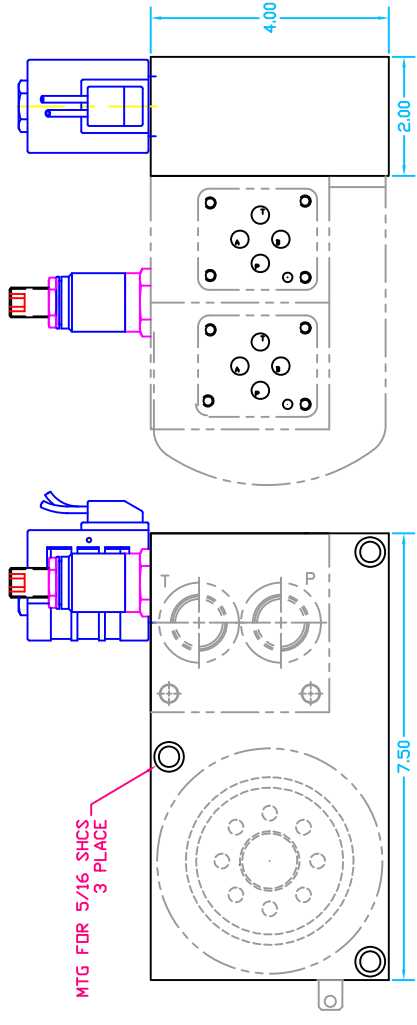

MTG FOR 5/16 SHCS 3 PLACE

3/4 NPT FILTER OUTLET

AUX. FILTER INLET

#10 SAE PRESSURE INLET

FILTER DRAIN VALVE

O-RING SEAL 2 PLACE

PME-3279A	1 STA.	COMMON CAVITY
PME-3280A	1 STA.,	W/ COMMON CAVITY
PME-2939A	2 STA.	
PME-1735A	2 STA.,	W/ COMMON CAVITY
PME-3030A	3 STA.	
PME-3058A	3 STA.,	W/ COMMON CAVITY
PME-3054A	4 STA.	
PME-3179A	4 STA.,	W/ COMMON CAVITY
PME-3325A	5 STA.	
PME-3352A	5 STA.,	W/ COMMON CAVITY

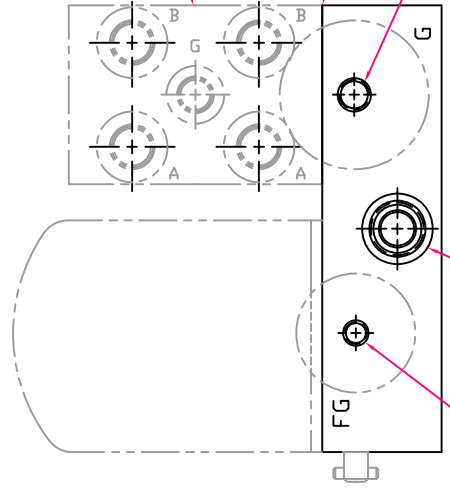

1/8 NPT 'DIRT' GAUGE

COMMON CAVITY FILTER BYPASS

-213 O-RING 2 PLACE  
1/4 NPT GAUGE PORT

INDEX

SCALE	INCH/METRIC

DATE	BY
09/27/02	MHV

DATE	BY

DESCRIPTION	JOB NO.	REV.
P&T Filter Manifold	PME-2667	3

DO NOT SCALE DRAWING

STANDARD TOLERANCE	GENERAL NOTES:
UNLESS OTHERWISE SPECIFIED +0.1 FOR 1 PLACE DECIMALS +0.005 FOR 2 PLACE DECIMALS +0.0005 FOR 3 PLACE DECIMALS +0.00005 FOR 4 PLACE DECIMALS ±1/2° FOR ANGLES	<ol style="list-style-type: none"> <li>COMMERCIAL TOLERANCES APPLY TO RAW STOCK.</li> <li>CHAMFER ALL EXTERNAL SHARP EDGES WHICH PRESENT A HAZARD.</li> <li>INTERNAL PASSAGES TO BE FREE OF BURRS OR ANY FOREIGN DEBRIS.</li> </ol>

# RV10-10

## Relief valve

### Functional Symbol

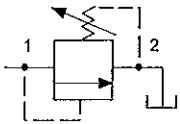

### Sectional View

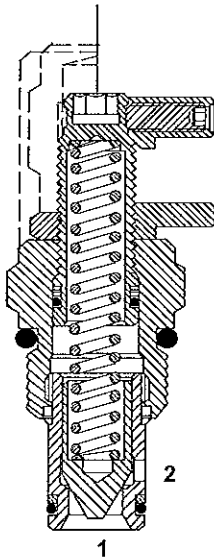

### Description

The RV10-10 is a direct acting, poppet type, screw-in cartridge relief valve.

### Operation

This valve remains closed from port 1 to port 2 until the predetermined setting has been reached at port 1. The poppet is unseated and allows flow out of port 2.

### Ratings and specifications

*Performance data is typical with fluid at 21,8 cSt (105 SUS) and 49°C (120°F)*

Typical application pressure (all ports) .....	70 bar (1000 psi)
Cartridge fatigue pressure (infinite life) .....	70 bar (1000 psi)
Rated flow .....	38 l/min (10 USgpm)
Cavity .....	C-10-2 (See page 72)
Standard housing materials .....	Aluminum
Temperature range .....	-40 to 120°C (-40° to 248°F)
Fluids .....	All general purpose hydraulic fluids such as: MIL-H-5606, SAE 10, SAE 20, etc.
Filtration .....	Cleanliness code 18/16/13
Weight cartridge only .....	0,22 kg. (0.48 lbs.)
Seal kits .....	565803 Buna-N 566086 Viton®

*Viton is a registered trademark of E.I.DuPont*

### Pressure Override Curves

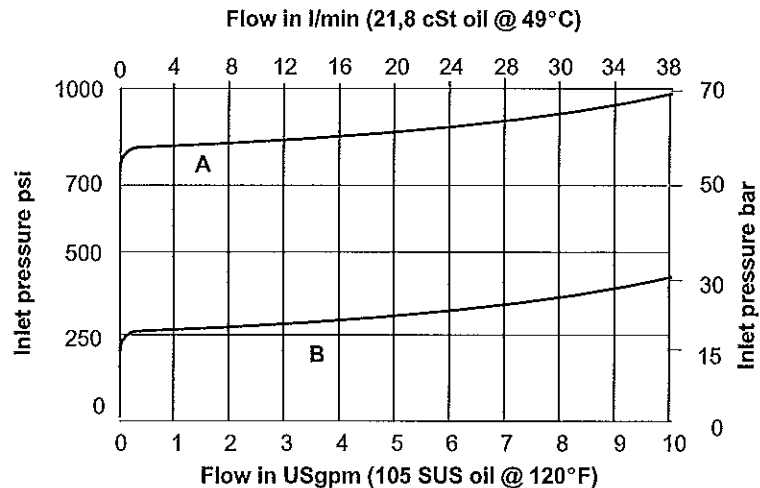

A – 10 spring  
B – 5 spring

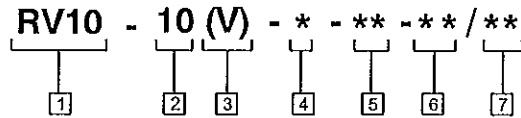

**1 Function**  
RV10 – Relief valve

**2 Size**  
10 – 10 Size

**3 Seals**  
Blank – Buna-N  
V – Viton

**4 Adjustment**  
C – Cap  
K – Knob  
S – Screw  
T – Tamper-proof

**5 Port size**  
O – Cartridge only

Code	Port size	Housing number	
		Aluminum Light duty	Aluminum Fatigue rated
3B	3/8" BSPP	02-175462	—
6T	SAE 6	566151	—
2G	1/4" BSPP	—	876702
3G	3/8" BSPP	—	876703
6H	SAE 6	—	876700
8H	SAE 8	—	876701

See pages 75 for housings

**6 Cracking pressure range**  
2 – 1,73 - 17 bar (25 - 250 psi)  
5 – 3,5 - 35 bar (50 - 500 psi)  
10 – 17 - 70 bar (250 - 1000 psi)

**7 Factory set reduced pressure**  
Within ranges in **6**  
Blank – Normal factory setting at approximate mid-range.  
User requested settings in 3,45 bar (50 psi) steps, coded as in the following examples:  
10 – 70 bar (1000 psi)  
9.5 – 65 bar (950 psi)

## Dimensions

mm (inch)

*Torque cartridge in housing*  
47–54 Nm (35–40 lbf ft)

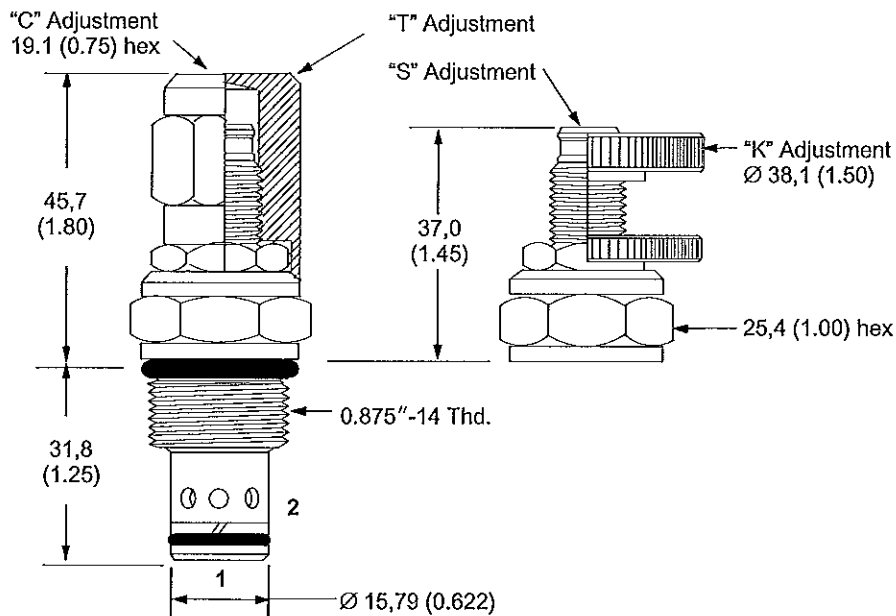



# LPS04 Series



## Assembly Features

Economical, low-pressure filter offering spin-on convenience and a broad choice of media ratings.

Working Pressures to  
200 psi / 1380 kPa / 13.8 bar

Minimum Burst (Rated Static) Pressure to  
375 psi / 2587 kPa / 25.9 bar

Flow Ranges: 0 - 25 gpm / 0 - 95 l/min

Bypass Ratings:  
25 psi / 172.5 kPa / 1.7 bar  
5 psi / 34.5 kPa / .34 bar

Port size: 3/4" NPT

Operating Temperatures:  
-20° F to 225° F / -27° C to 107° C

Die cast aluminum head & steel body for strength and durability.

Assembly weight (approximate): 2.2 lbs.

## Spin-on Filters

Available with cellulose media: 3µ, 10µ, 25µ; wire mesh, and water absorbing.

Available in master carton quantities.

## Applications

Low Pressure In-Plant and Mobile Applications

1/8" NPT GAUGE PORT, 2-PLCS

**Assembly Side View**

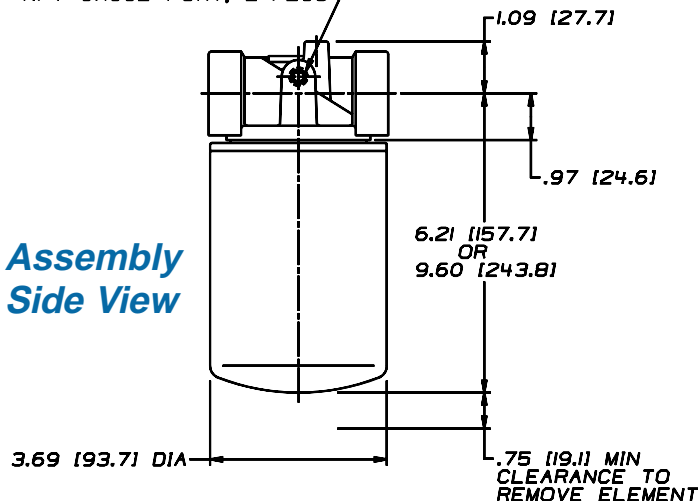

1/4-20 UNC-2B THD, 2-PLCS

**Head Top View**

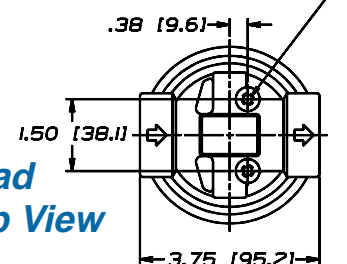

# LPS04 Mix 'n Match System

The Donaldson mix 'n match system provides the performance and functional advantages of custom-engineered filters with the convenience and speedy delivery of in-stock parts.

Create your own filter model from among the filters and heads shown below.

## Head Assemblies

Port Size	Bypass Rating	Part Number
3/4" NPT	5 psi / 34.5 kPa / .34 bar	P171207
3/4" NPT	25 psi / 172.5 kPa / 1.72 bar	P167848

## Filter Service Gauges



Part Number	Bypass Rating
P174486	5 psi / 34.5 kPa / 0.3 bar
P174772	25 psi / 172.5 kPa / 1.7 bar

### Note

- Donaldson service indicator gauges fit into 1/8" NPT ports.
- See Donaldson brochure #F112085 for more information.

## Spin-On Filters

Media Type	B <sub>(x)</sub> = 2 Rating	Length		Part Number
		in	mm	
Cellulose	3μ	5.21	132	P551550
Cellulose	10μ	5.21	132	P551551
		8.6	218	P550255
Cellulose	25μ	5.21	132	P551553
		8.6	218	P550256
Cellulose	25μ	5.21	132	P551554
<i>Water Absorption Media</i>				
Wire Mesh	150μ	5.76	146	P550274

### Note

All models have 1"-12 threads and measure 3.66" / 93mm outer diameter.

## Performance Curves

### LPS04 Filter Only (5.2"/132mm)

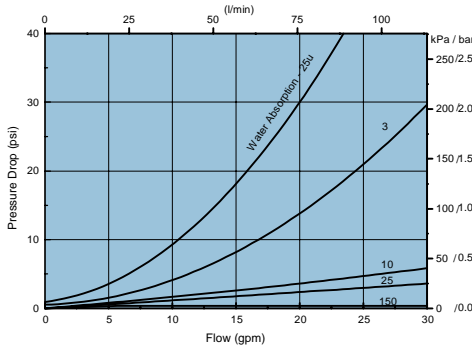

### LPS04 Head Only

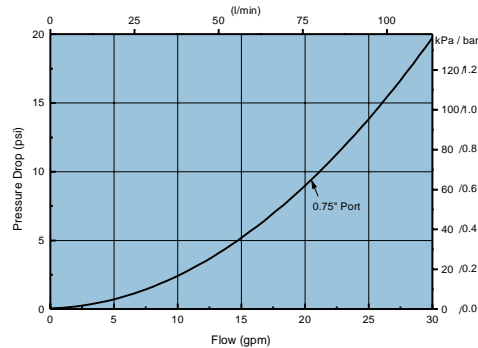

### LPS04 Filter Only (8.6"/218mm)

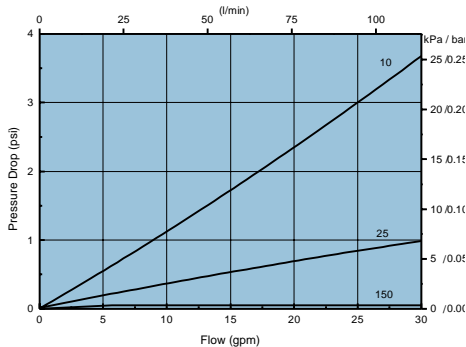

## Performance Notes

- All flow measurements were made with 150 SSU hydraulic oil at 100°F (37.7°C), fluid specific gravity of 0.9.
- The numbers on the curves above refer to specific Donaldson media formulations. Refer to service element listing for beta ratings and part numbers.
- Pressure Drop Calculation: Clean Filter Assembly = head ΔP + element ΔP

### Calculation Definitions:

- ΔP<sub>E</sub> = Element pressure drop from curve
- ΔP<sub>M</sub> = Corrected element pressure drop
- S.G. = New specific gravity
- SSU = New SSU viscosity (Saybolt Seconds Universal)
- cSt = New cSt viscosity (centistokes)
- cP = New cP viscosity (centipoise)

To correct element drops for viscosity and/or specific gravity, use one of these formulae:

- or • ΔP<sub>M</sub> = ΔP<sub>E</sub> x (SSU/150) x (S.G. / 0.9)
- or • ΔP<sub>M</sub> = ΔP<sub>E</sub> x (cSt/32) x (S.G. / 0.9)
- or • ΔP<sub>M</sub> = ΔP<sub>E</sub> x (cP/29)

# Donaldson

### United States

Tel: 800-374-1374

Fax: 612-887-3716

Service Tips by FAX: 800-374-8202

www.donaldson-filters.com

### Latin America & Caribbean

Tel.: 954-236-2404

Fax: 954-236-2403

### Mexico

Tel.: 525-362-73-20

Fax: 525-397-86-54

### Europe

Tel.: 32-16-383811

Fax: 32-16-400077

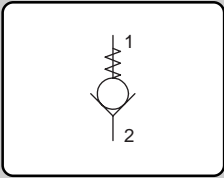

**D04B2**

UP TO **160** L/MIN **42** USGPM  
AND **420** BAR **6000** PSI



**CHECK VALVE  
BALL TYPE**

- Low leakage - less than 3 drops/min.
- Ball type construction for cost effective design.
- Single and dual pilot pistons available to create pilot to open check.
- Range of cracking pressures available.
- Good contamination tolerance.
- External parts zinc plated.

**OPERATION**

The spring-loaded ball is shifted by low pressure on port [2] allowing free flow to port [1].

*Reverse flow, [1] to [2], is blocked.*

Valves can be pilot operated using a pilot piston operating through port [2], (see pages **352-355** for details).

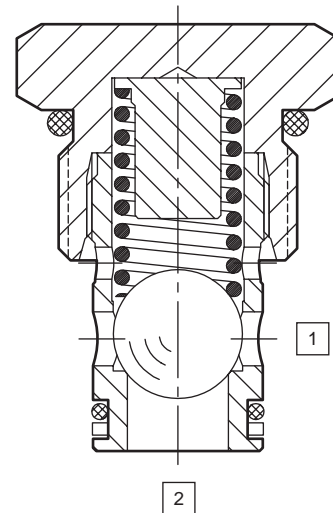

**SPECIFICATIONS**

<b>BASIC MODEL NUMBER</b>	<b>D04B2</b>
<b>SYMBOL</b>	
<b>NOMINAL FLOW AT Δp = 7 bar 100 psi</b>	90 l/min 24 USgpm
<b>PRESSURE</b>	420 bar 6000 psi
<b>LEAKAGE</b>	Less than 3 drops/min
<b>FLUID *</b>	MINERAL OIL OR SYNTHETIC FLUID WITH LUBRICANT PROPERTIES
<b>IDEAL VISCOSITY *</b>	15 - 50 cSt 80 - 230 SSU
<b>SEAL MATERIAL / TEMPERATURE *</b>	NITRILE (Std.) -30°C to +100°C BUNA-N -20°F to +210°F VITON -20°C to +150°C -4°F to +330°F
<b>FILTRATION *</b>	25 MICRONS (Nom.) OR BETTER
<b>WEIGHT</b>	0.08 kg 0.18 lb
<b>CAVITY</b>	CAV04-2

\* **IMPORTANT:** See pages **582-583** for additional notes on operating conditions.

Specifications may change without notice

**TYPICAL PERFORMANCE**

Measured at 30 cSt 140 SSU (For cartridge only)

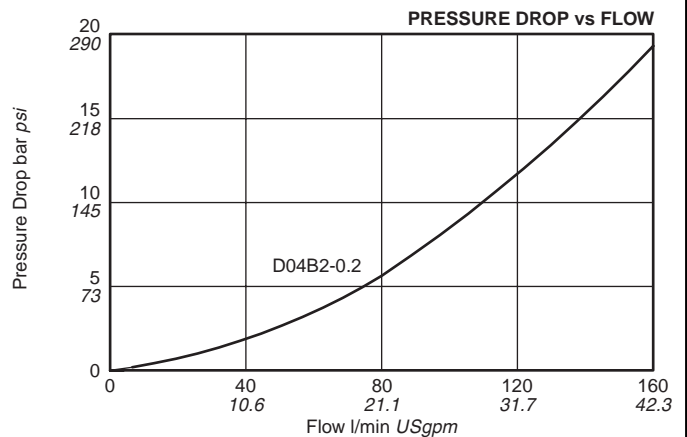



## DIMENSIONS

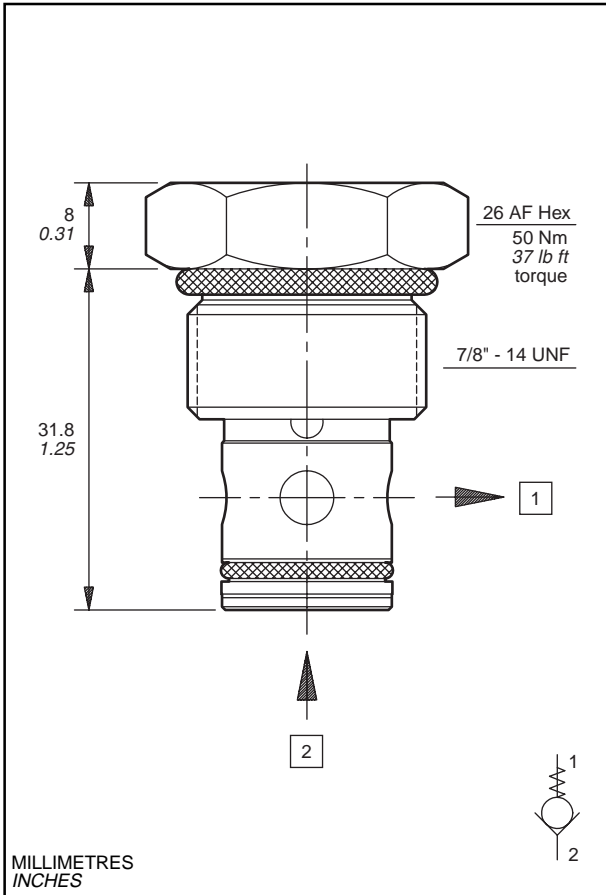

## CARTRIDGE

**D04B2**

CRACKING PRESSURE	0.0	0.0 bar	0 psi
	0.2	0.2 bar	3 psi (Std.)
	1.0	1.0 bar	15 psi
	2.1	2.1 bar	30 psi
	3.4	3.4 bar	50 psi
	6.9	6.9 bar	100 psi
	10.0	10.0 bar	145 psi
SEAL MATERIAL	N	NITRILE <i>BUNA-N</i> (Std.)	
	V	VITON	

IF NO CRACKING PRESSURE IS SPECIFIED,  
VALVE WILL BE SUPPLIED AS **D04B2-0.2**

## LINE BODY

**CAVITY CAV04-2: 7/8-14 Thread (10-2 Industry common cavity)**

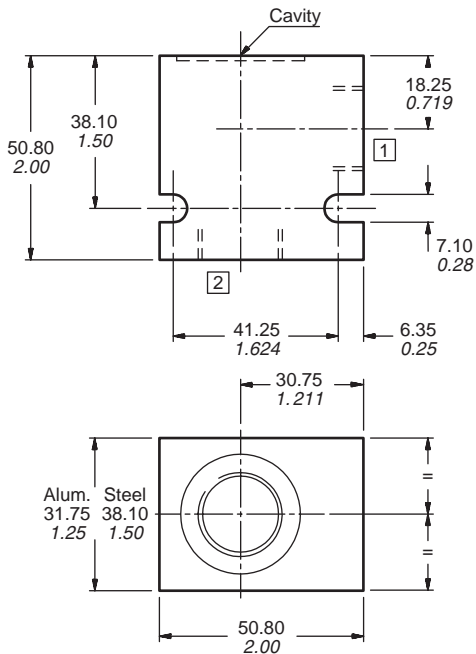

## LINE BODY

**LB10**

PORTING	705	1/2 SAE	708	3/4 SAE
	707	1/2 BSP	709	3/4 BSP
LINE BODY MATERIAL	A	ALUMINIUM (Anodised) TO 210 bar 3000 psi		
	S	STEEL (Zinc plated) TO 420 bar 6000 psi		

LINE BODY DETAILS page 513 for 708 / 709 consult factory

## SEAL KIT

SK30516N-1 (NITRILE *BUNA-N*)  
SK30516V-1 (VITON)

## CAVITY TOOLING FOR CAV04-2

	MM	INCH		
PILOT DRILL Ø	15.00	0.59	REAMER (STEEL)	8RM31079S
STEP DRILL	8DS31367		COUNTERBORE	-
REAMER (ALUM)	8RM31079A		TAP	8TP31201

MACHINING DETAILS PAGE 540

**STERLING HYDRAULICS**

SOLENOID  
PROPORTIONAL  
DIRECTIONAL  
DIVERTER  
SHUTTLE  
CHECK  
RELIEF  
SEQUENCE  
PRESSURE  
LOAD  
FLOW  
LINE  
CAVITIES  
TECHNICAL DATA

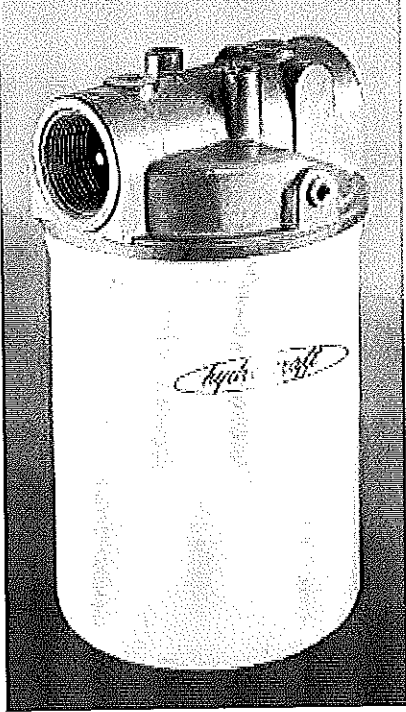

## Return Line Filters

The Hydro-Craft® range of spin-on filters are designed for return line applications and have a nominal retention of 10 micron as standard. 25 micron canisters are available.

Hydro-Craft offers three basic models which are interchangeable with most suppliers of this filter type. The filters are rated at 200 PSI (13 bar) working pressure with bypass, and have flow rates of 15 to 50 GPM at 10 micron. **WARNING:** 80 PSI ΔP maximum pressure without bypass valve in filter head.

Hydro-Craft® spin-on filters are designed for use with mineral-based oils as used in mobile, industrial, marine and agricultural applications.

### DESIGN FEATURES

- Full flow 10 micron—standard
- Optional 25 micron
- 200 PSI working pressure with bypass
- Interchangeable elements
- Visual indicator available in standard or custom design
- Disposable spin-on canister
- With 15 PSI bypass (1 bar)

HC-RS-30D  
Dial  
Indicator

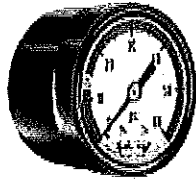

### SPECIFICATIONS

PART NO.	PORT SIZE (IN)	FLOW RATE (GPM)	MICRON RATING	DIAL INDICATOR
<b>30 SERIES</b>				
HC-RS-30-12X	3/4"	15	10 Micron Std. 25 Micron Opt.	No
HC-RS-30-12D	3/4"	15	10 Micron Std. 25 Micron Opt.	Yes
HC-RS-30-16X	1"	20	10 Micron Std. 25 Micron Opt.	No
HC-RS-30-16D	1"	20	10 Micron Std. 25 Micron Opt.	Yes
<b>50 SERIES</b>				
HC-RS-50-20X	1-1/4"	55	10 Micron Std. 25 Micron Opt.	No
HC-RS-50-20D	1-1/4"	55	10 Micron Std. 25 Micron Opt.	Yes
<b>BAYONET FILTER ADAPTER</b>				
HC-120-BFA				
HC-120-FA				

Our Bayonet Flange Adapters, HC-120-BFA and HC-120-FA, will replace the filler breather cap, allowing use of a spin-on filter. The flange adapter will accommodate all series RSE filters. Select the appropriate size and micron rating for your application.

### REPLACEMENT ELEMENTS

PART NO.	MICRON RATING
<b>30 SERIES</b>	
RSE-30-10	10 Micron
RSE-30-25	25 Micron
<b>50 SERIES</b>	
RSE-50-10	10 Micron
RSE-50-25	25 Micron

Replacement dial gauge indicator  
HC-RS-30-D fits 30 and 50 series filters

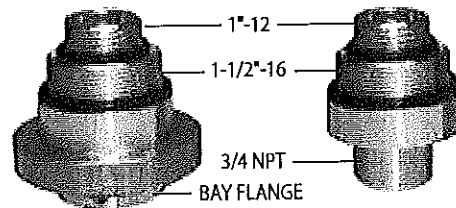

HC-120-BFA      HC-120-FA  
Bayonet Filter Adapters

All dimensions are approximate in inches

# Return Line Filters Series HCRS 30 and 50

## TECHNICAL DATA

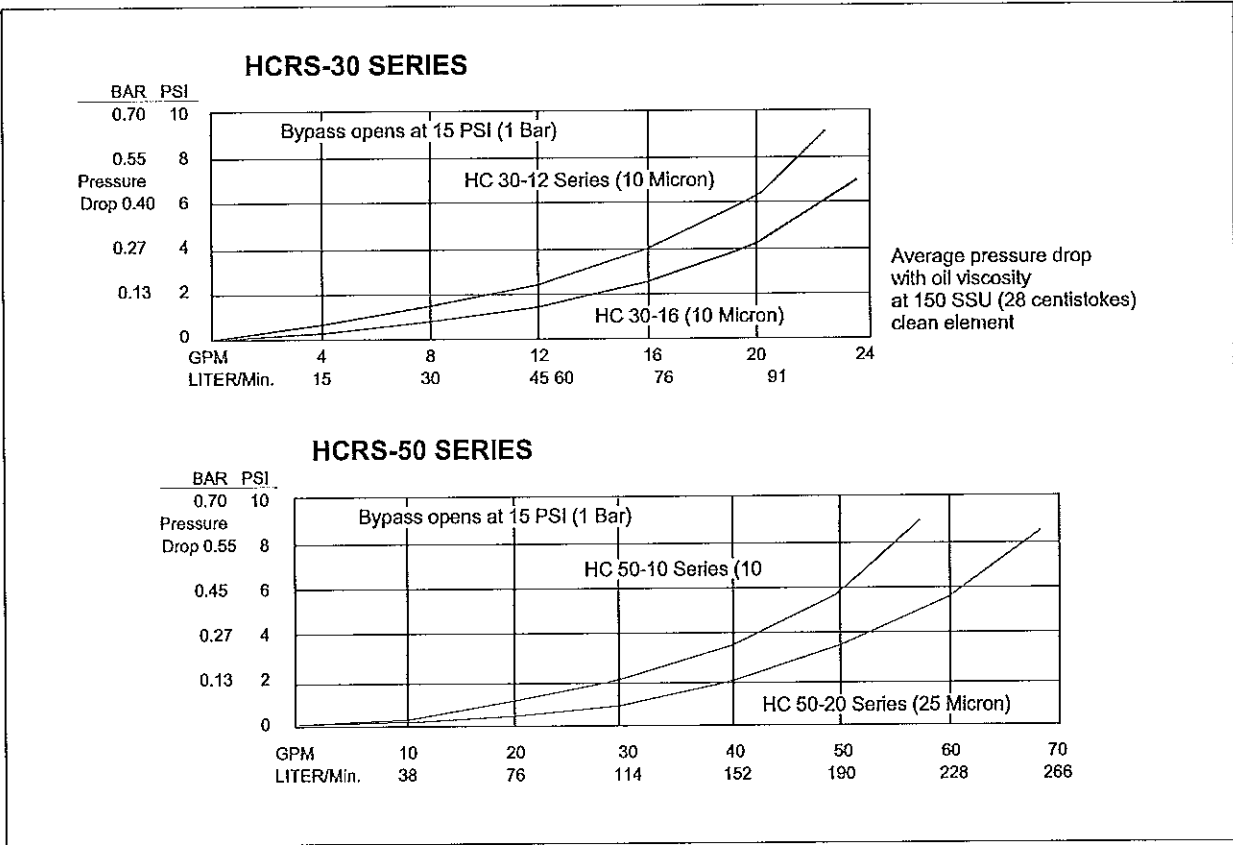
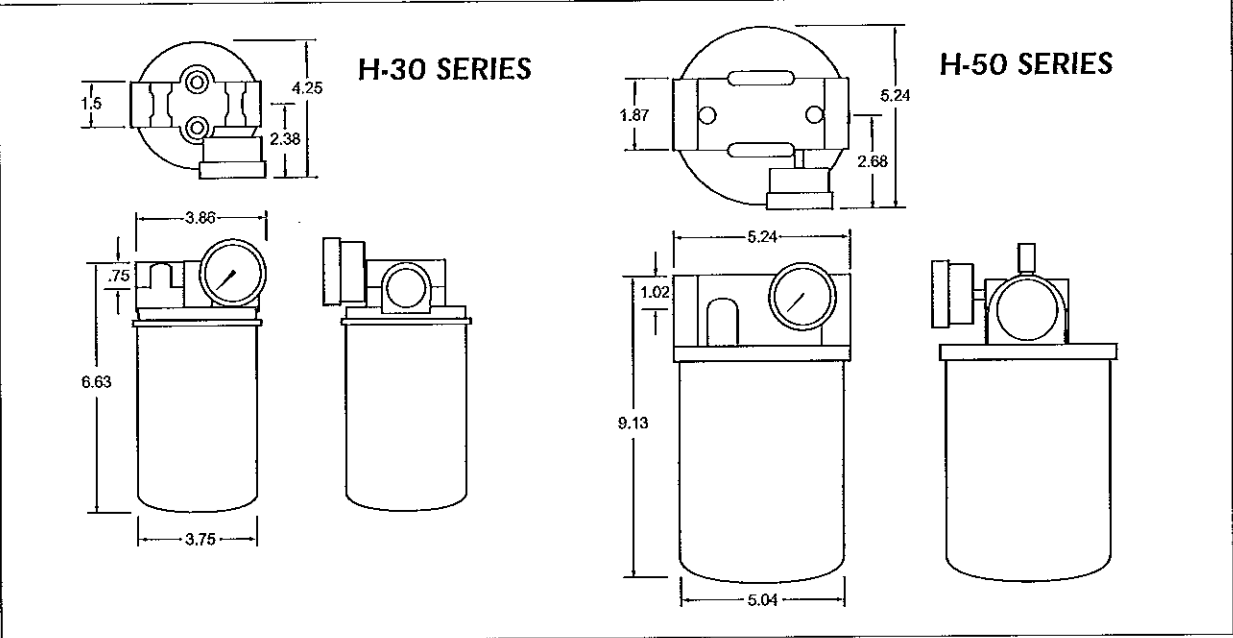

# Industrial Gauges

## Type 21X.53

- **Copper Alloy Wetted Parts**
- **Stainless Steel Case**
- **Field Liquid Fillable**



Type 212.53 - Dry case  
Type 213.53 - Liquid filled case

WIKA Type 21X.53 gauges feature a stainless steel case for protection in harsh environments. The o-ring seal around the connection makes this gauge field liquid fillable.

### Standard Features

- **Nominal Case Size:** 2" (53 mm), 2½" (68 mm), 4" (100 mm)
- **Case Material:** 304 stainless steel
- **Wetted Parts:** Copper alloy
- **Window Type & Material:** Polycarbonate; (4") Acrylic
- **Removable Window:** No
- **Dial Material:** White ABS (2" & 2½") and white aluminum (4")
- **Bezel Ring Type & Material:** Crimp on SS
- **Liquid Fillable Gauge:** Yes
- **Case-to-Socket O-ring Material:** BUNA-N- factory glycerine filled; Viton- dry or factory silicone filled
- **"Other" Gaskets/O-ring Types & Materials:** Window gasket, BUNA-N
- **Pointer Material/Type:** Black aluminum
- **Adjustable Pointer:** No
- **Accuracy:**  $\pm 2/1/2\%$  of span ASME B40.100 Grade A (2", 2½");  $\pm 1\%$  of span ASME B40.100 Grade A (4")
- **Connection Locations:** LM (Lower Mount), CBM (Center Back Mount), LBM (Lower Back Mount)
- **Media Operating Temperature:** Max. 140°F
- **Ambient Operating Temperature:** -40°F to 160°F dry; -4°F to 140°F glycerine filled; -40°F to 140°F silicone filled

### Available Options

- "Dampened Movement" Option: No
- U-Clamp Bracket: Yes (CBM only)
- Front Flange: Yes (CBM only)
- Rear Flange: Yes (LM & CBM)
- Restrictor: Yes
- Safety Glass Window: Yes (on special request)
- Instrument Glass Window (flat glass): No
- Drag Pointer (maximum reading indicator): Yes (2½" & 4") (drag pointer reduces standard accuracy)
- Cleaned for Use in Oxygen Service: Yes (dry only)
- Panel Mount Kit: Yes (see front flange and u-clamp option)
- Magnetic or Inductive Contact Switches: No
- Receiver Gauge Scales: No
- Special Connection: Limited to wrench flat area

### Data sheet: 21X.53

Items shown with part numbers indicate readily available standard WIKA products. Items shown without part numbers are available on special order.

**Note:** For options not shown - consult your WIKA Distributor or the Factory.

Type	213.53- liquid filled					
Connection	LM			CBM		
Conn. Size	1/4" NPT					
Size	2 1/2"					
Press. Scale <sup>1</sup>	PSI	PSI/BAR	PSI/KG/CM <sup>2</sup>	PSI	PSI/BAR	PSI/KG/CM <sup>2</sup>
30" Hg	9767002	9691957	9693683	9767185	9692139	9693861
30"-0-15 PSI						
30"-0-30 PSI	9767010	9691965	9693691			
30"-0-60 PSI	9767029	9691974	9693705			
30"-0-100 PSI						
30"-0-160 PSI						
30"-0-200 PSI						
15 PSI	9767037	9691982	9693713			9697220
30 PSI	9767045	9691990	9693721	9767193	9692147	9693879
60 PSI	9767053	9692007	9693739	9767202	9692155	9693887
100 PSI	9767061	9692015	9693747	9767215	9692164	9693895
160 PSI	9767070	9692024	9693755	9767223	9692172	9693909
200 PSI	9767088	9692032	9693764	9767231	9692180	9693917
300 PSI	9767096	9692040	9693772	9767240	9692198	9693925
400 PSI	9767100	9692058	9693780			
600 PSI	9767118	9692066	9693798	9768947	9692202	9693934
800 PSI						
1,000 PSI	9767126	9692075	9693802	9767258	9692210	9693942
1,500 PSI	9767134	9692083	9693810	9768165	9692228	9693950
2,000 PSI	9767142	9692091	9693828	9768939	9692236	9693968
3,000 PSI	9767150	9692105	9693836	9767266	9692245	9693976
5,000 PSI	9767169	9692113	9693845	9767274	9692253	9693985
6,000 PSI		9748207				
10,000 PSI	9767177	9692121	9693853	9767282	9692261	9693993
15,000 PSI						

<sup>1</sup>PSI/BAR denotes dual scale; PSI outside in black, BAR inside in red. \*PSI/KG/CM<sup>2</sup> denotes dual scale; PSI outside in black, KG/CM<sup>2</sup> inside in red.  
 Note: Vacuum scale: 30" Hg outside in black; 760 mm Hg inside in red.

Type	213.53-liquid filled					
Connection	LM			LBM		
Conn. Size	1/4" NPT		1/2" NPT	1/4" NPT		1/2" NPT
Size	4"					
Press. Scale <sup>1</sup>	PSI	PSI/KG/CM <sup>2</sup>	PSI	PSI/BAR	PSI/KG/CM <sup>2</sup>	PSI/BAR
30" Hg	9699028	9694000		9734427	9694239	9734533
30"-0-15 PSI	9699036	9694018				
30"-0-30 PSI	9699045	9694026				
30"-0-60 PSI	9699053	9694035				
30"-0-100 PSI	9699061	9694043				
30"-0-160 PSI	9699079	9694051				
30"-0-200 PSI	9699087	9694069				
15 PSI	9699095	9694077		9734320		9734435
30 PSI	9699109	9694085		9734338	9694247	9734444
60 PSI	9699117	9694094		9734346	9694255	9734452
100 PSI	9699125	9694107		9734355	9694264	9734460
160 PSI	9699257	9694115		9734363	9694272	9734478
200 PSI	9699134	9694124			9694280	
300 PSI	9699142	9694132		9734371	9694298	9734486
400 PSI	9699150	9694140			9697743	
600 PSI	9699168	9694158		9734389	9694302	9734495
800 PSI	9699176					
1,000 PSI	9699185	9694166	4228732	9734397	9694310	9734508
1,500 PSI	9699193	9694175	9766885	9734401	9694328	9734516
2,000 PSI	9699206	9694183	9766876	4201591	9694336	
3,000 PSI	9699215	9694191	9766893	9734419	9694345	9734525
5,000 PSI	9699223	9694205	9766906	4201604	9694353	
10,000 PSI	9699231	9694213	9766915		9694361	
15,000 PSI	9699249	9694221				

<sup>1</sup>PSI/BAR denotes dual scale; PSI outside in black, BAR inside in red. \*PSI/KG/CM<sup>2</sup> denotes dual scale; PSI outside in black, KG/CM<sup>2</sup> inside in red.  
 Note: Vacuum scale: 30" Hg outside in black; 760 mm Hg inside in red.

**Dimensions:**

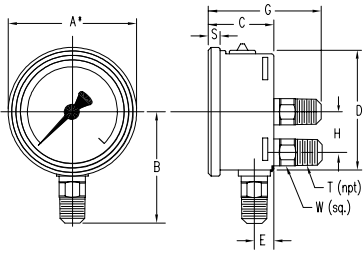

21X.53 LM/CBM/LBM

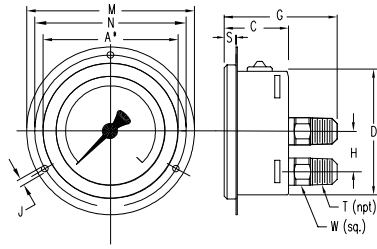

21X.53 CBM/LBM/FF

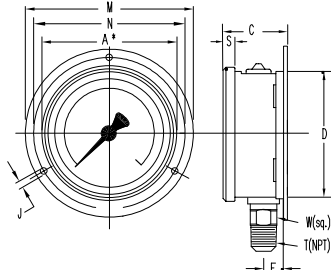

21X.53 LM/RF

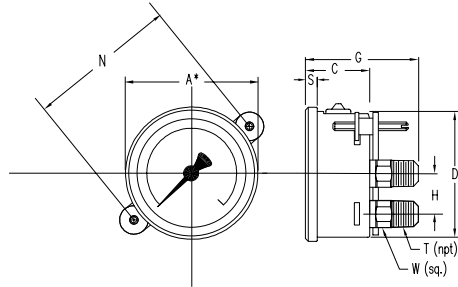

21X.53 CBM/LBM/UC

A\* NOMINAL SIZE

TYPE/SIZE	WEIGHT	KEY	A*	B	C	D	E	G	H	J	L	M	N	S	T	W
21X.53 2"	0.27 lbs. + 0.06 lbs. if filled	mm	50	48	30	50	12	53	--	3.6	6.5	71	60	5.5	--	14
		in	2	1.89	1.18	1.97	0.47	2.09		0.14	0.26	2.80	2.36	0.22	1/4"	0.55
21X.53 2.5"	0.36 lbs. + 0.08 lbs. if filled	mm	63	54	32	62	13	54	--	3.6	7.5	85	75	6.5	--	14
		in	2.5	2.13	1.26	2.44	0.51	2.13		0.14	0.30	3.35	2.95	0.26	1/4"	0.55
21X.53 4"	1.10 lbs. + 0.66 lbs. if filled	mm	100	87	48	100	15.5	79.5	30	4.8	9	132	116	8	--	22
		in	4	3.43	1.89	3.94	0.61	3.13	1.18	0.19	0.35	5.20	4.57	0.31	1/2"	0.87

NOTE: For 1/4" NPT connections on 3" and 4" gauges, reduce B\* dimension by 5 mm / 0.2 in.

**Optional Type 213.53S- 7/16" - 20" SAE Connection**

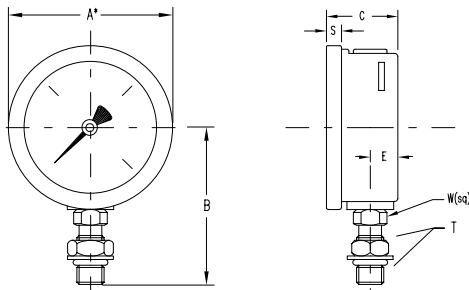

A\* NOMINAL SIZE

TYPE/SIZE	WEIGHT	KEY	A*	B	C	E	S	W
213.53S 2.5"	0.51 lbs.	mm	63	61.2	31	13	6	14
		in	2.5	2.41	1.23	.51	.24	.55

T = 7/16-20" SAE Connection  
supplied with Viton o-ring, hex nut, and washer

THE MEASURE OF  
**Total Performance™**

**Ordering Information:**

State computer part number (if available) / type number / size / range / connection size and location / options required.

Specifications given in this price list represent the state of engineering at the time of printing. Modifications may take place and the specified materials may change without prior notice



**WIKAL Instrument Corporation**  
1000 Wiegand Boulevard  
Lawrenceville, Georgia 30043-5868  
Tel: 770-513-8200 Fax: 770-338-5118  
<http://www.wika.com> e-mail: [info@wika.com](mailto:info@wika.com)



## Pneu-Trol

# MALE-TO-FEMALE FLOW CONTROL, NEEDLE AND CHECK VALVES

- Eliminates Need for Extra Pipe Nipple

### FLOW CONTROL

A spring biased ball provides full flow in one direction; a tapered needle provides a wide range of adjustment of flow in the controlled direction. A locknut prevents unwanted changes in adjustment. A tamperproof adjustment key is standard; a knurled knob is optional at slight extra cost.

### NEEDLE

A wide range of flow adjustment is possible because of the fine thread, tapered needle. Unwanted changes in adjustment are prevented by a locknut. A tamperproof adjustment key is standard; a knurled knob is available at slight extra cost.

### CHECK

A slight pressure differential fully opens or closes the ball or poppet check valve. This valve is available with either ball check or bubble-tight poppet check.

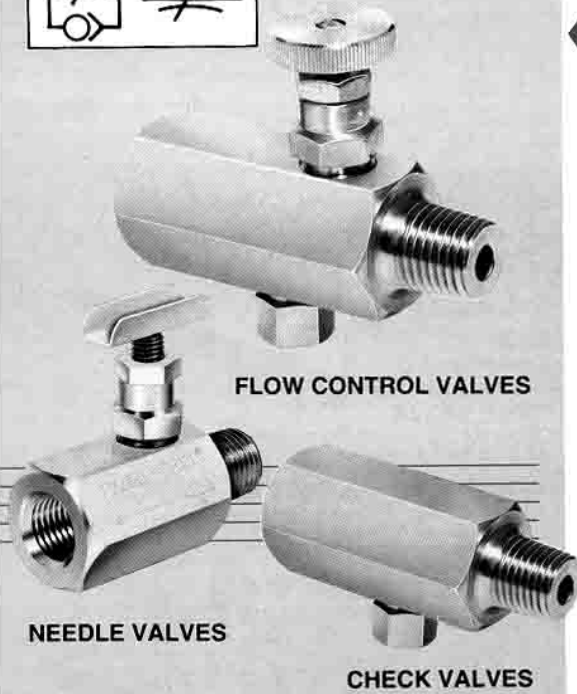

FLOW CONTROL VALVES

NEEDLE VALVES

CHECK VALVES

### SPECIFICATIONS

#### Maximum Operating Pressure (Non-Shock Service)

Brass – 2,000 PSI (138 Bar)

Carbon Steel – 5,000 PSI (345 Bar)

#### Operating Temperature Range (O-Ring Packing)

Viton: -15° to +400° F (-26° to 203°C)

#### Threads

NPTF Standard, 1/8", 1/4", 3/8" and 1/2"

#### Materials

Housing, Plug, Body – Hexagon Brass,  
Hexagon Carbon Steel

Needle – 416 Stainless Steel on  
Steel Valves

Needle – Brass on Brass Valves

Back-up Washer – Teflon

Knob – Aluminum

Tamperproof Key – Cadmium Plated Steel

Ball – Stainless Steel

Retainer – Stainless Steel

Spring – Stainless Steel

### DIMENSIONS

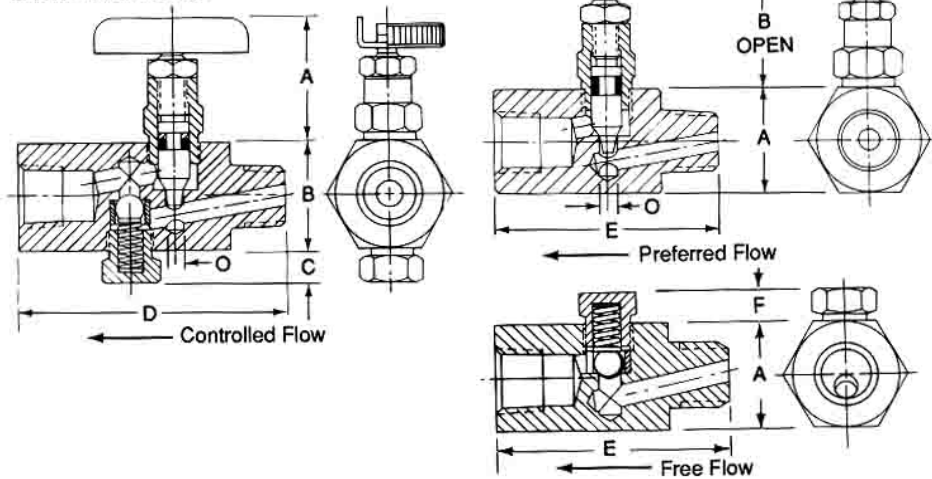

### ORDERING INFORMATION

SERIES	TYPE	SIZE	MATERIAL
F	MF	10	B

F = Flow Control  
N = Needle  
C = Check

Male-to-Female  
Pipe Threads

10 = 1/8"  
20 = 1/4"  
25 = 3/8"  
30 = 1/2"

B = Brass  
S = Steel

#### Example:

To order 1/4" brass male-to-female needle valves with knob, specify NMF20BK.

PIPE SIZE	A HEX	B	C	D	E	F	O
1/8"	11/16 (17.5)	7/8 (22.0)	13/64 (5.0)	1-3/4 (44.5)	1-15/32 (37.5)	—	.107 (2.5)
1/4"	7/8 (22.0)	1 (25.5)	23/64 (9.0)	2-3/8 (60.5)	2 (51.0)	23/64 (9.0)	.156 (4.0)
3/8"	1-1/16 (27.0)	1-13/16 (46.0)	11/32 (8.5)	2-3/4 (70.0)	2-1/4 (57.0)	—	.219 (5.5)
1/2"	1-5/16 (33.5)	1-7/16 (36.5)	15/32 (12.0)	3-3/16 (81.0)	2-21/32 (61.5)	—	.281 (7.0)

( ) Parentheses = Millimeters

### ORDERING INFORMATION

SIZE	FLOW CONTROL VALVES	FLOW CHECK	NEEDLE VALVES		Max. Open Needle Cv	CHECK* VALVES
	Brass	Cv	Brass	Carbon Steel		
1/8"	FMF10BK	.23	NMF10BK	—	.20	—
1/4"	FMF20BK	.54	NMF20BK	NMF20SK	.43	CPMF20B
3/8"	FMF25BK	.83	—	NMF25SK	.78	—
1/2"	FMF30BK	1.47	—	NMF30SK	1.24	—

\* Poppet Style Check.

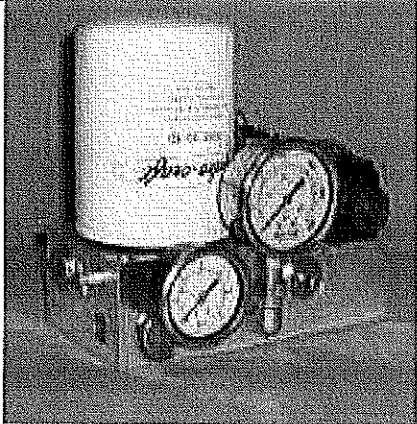

# Filter Manifolds

New versatile manifolds from Hydro-Craft® will reduce your build cost and increase your overall flexibility.

- Return filter head with filter and check port (1"x12 threads)
- Gauge ports for filter and working pressure
- Manual filter drain
- Common relief or unloading valve cavity and auxiliary return port
- P & T manifold will accommodate D03 1 to 5 station or D05 single station
- Return manifold may be used in horizontal or vertical applications
- Includes o-ring seals to seal manifold to mating surface
- **CUSTOM ORDER** - Please contact Hydro-Craft

**P and T Version**  
PME-2667A-2

**D03 Bolt-On Manifolds Available**

PME-3279A	- 1 Station
PME-3280A	- 1 Station with Common Cavity
PME-2939A	- 2 Station
PME-1735A	- 2 Station with Common Cavity
PME-3030A	- 3 Station
PME-3058A	- 3 Station with Common Cavity
PME-3054A	- 4 Station
PME-3179A	- 4 Station with Common Cavity
PME-3325A	- 5 Station
PME-3352A	- 5 Station with Common Cavity

**D05 Single-Station Subplate**  
PME-2702A

**D03 Version**  
PME-2685A



## Solenoid Operated Directional Valves

**DG4V-3 flows to 80 l/min (21 USgpm), 6\* design**

**DG4V-3S flows to 40 l/min (10.5 USgpm), 6\* design**

**ISO 4401, size 03; ANSI/B93.7M-D03**

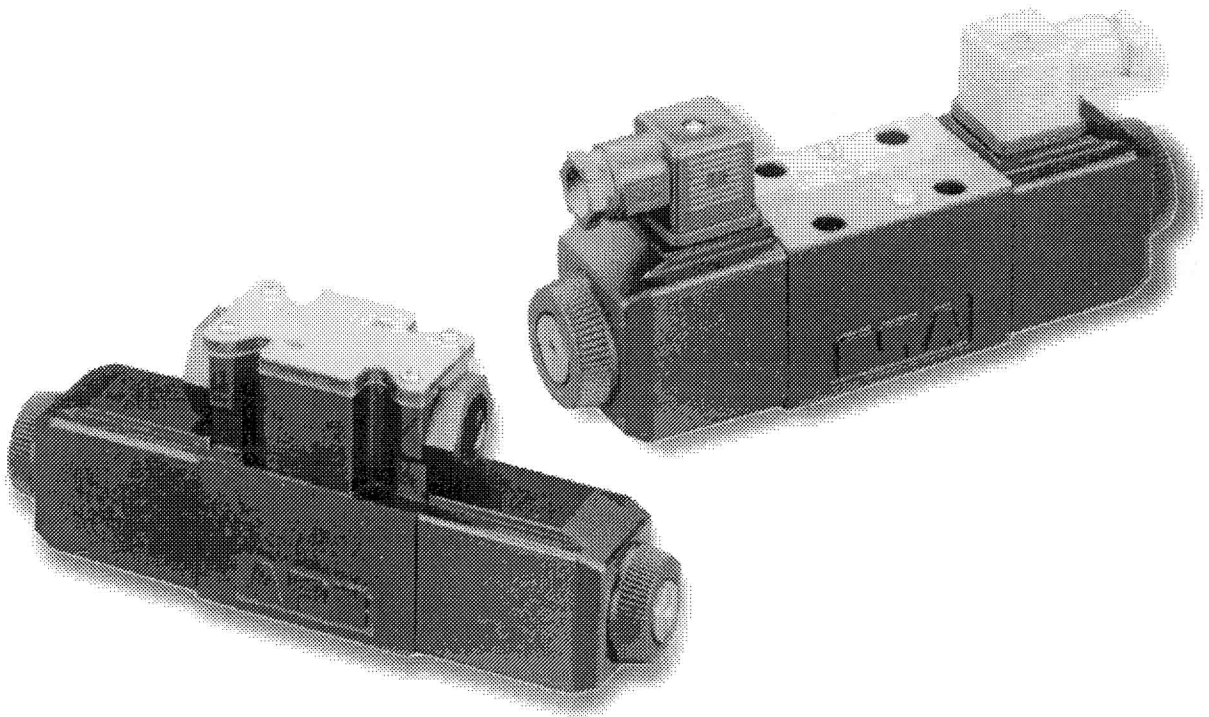

# Introduction

## General description

These solenoid operated directional control valves are for directing and stopping flow at any point in a hydraulic system. This 60-design series has been specially designed and developed to cover expanded demands in the industry as well as the many traditional uses of the earlier designs. Some of the more important benefits to users are outlined.

- Efficient control of greater hydraulic powers without increasing solenoid power consumption.
- Installed cost and space savings from higher power/weight-and-size ratios.

- Increases system efficiency; the result of improved manufacture of spools and bores.
- Installation flexibility resulting from choice of numerous combinations of solenoid connectors and locations.
- Multi-fluid capability without need to change seals.
- Higher sustained machine productivity and higher uptime because of proven fatigue life and endurance, tested over 20 million cycles.
- Solenoid coils can be changed quickly and easily without leakage from hydraulic system.
- Compact, cost effective system design when used with Vickers SystemStak™ valves and subplates.

## DG4V-3 and DG4V-3S High and standard performance models:

- Up to 80 l/min (21 USgpm) and up to 40 l/min (10.5 USgpm) respectively at 350 bar (5000 psi).
- Builds on Vickers experience as the major supplier of size 03 valves worldwide.
- Offers designers the opportunity to select the optimum value package for each application.
- International standard interface. The valve mounting face conforms to ISO 4401, size 03 and is compatible with related international standards.

## Features and Benefits

### • High pressure and flow capabilities, thanks to special design features

Highly reliable operation up to 80 l/min (21 USgpm) at 350 bar (5000 psi). Establishes new market standards and opens new possibilities to design engineers on valve size selection.

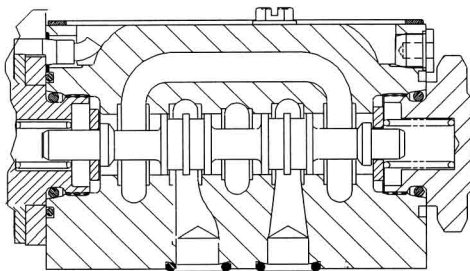

Typical maximum pressure differential (P-A-B-T) flow envelope, blocked center spool.

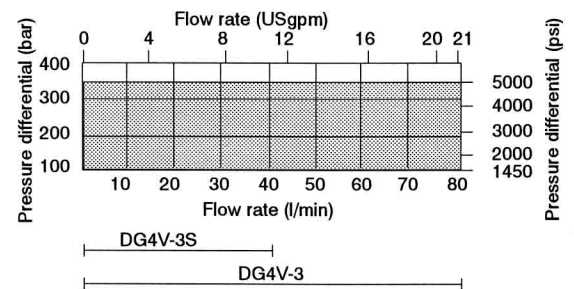

# Features and Benefits

- **Minimal pressure drop, i.e. 2,5 bar (36 psi) at 30 l/min (7.9 USgpm)**

Achieved by optimization of the valve body, spool and spool-stroke design. The results: low energy consumption and improved efficiency.

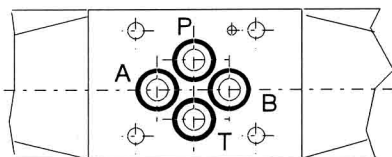
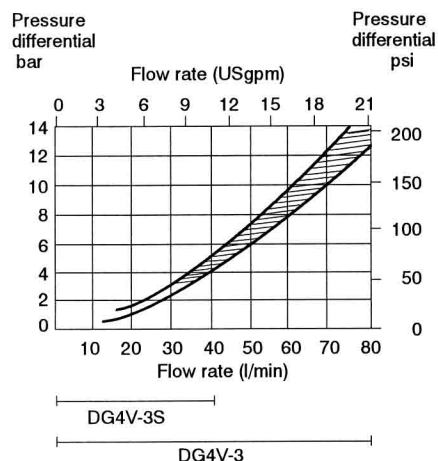

Mounting surface to ISO 4401 size 03

- **Ease of servicing**

Wet-armature solenoid, screw-in core tube design allows coils to be changed without removing valve from installation and without oil spillage or risk of contaminating system fluid.

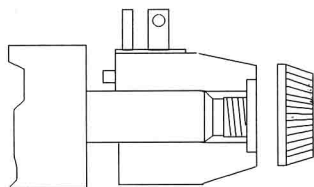

ISO4400 (DIN 43650) coil shown

- **High reliability**

Design of spring forces and profile of DC solenoid force characteristics ensure spool position selection under extreme operating conditions. Result is a valve with high reliability when being energized or de-energized.

**Performance leader**

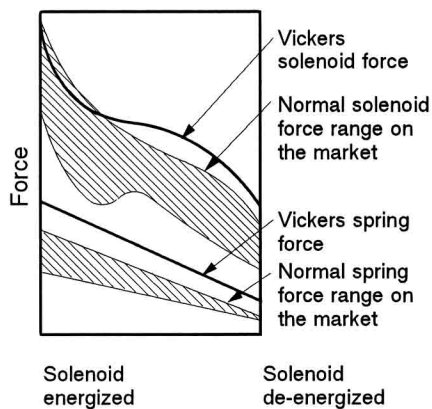

Solenoid energized

Solenoid de-energized

- **Electrical connections**

Conduit box design that simplifies electrical wiring connections to solenoids. Orientation tabs prevent incorrect positioning.

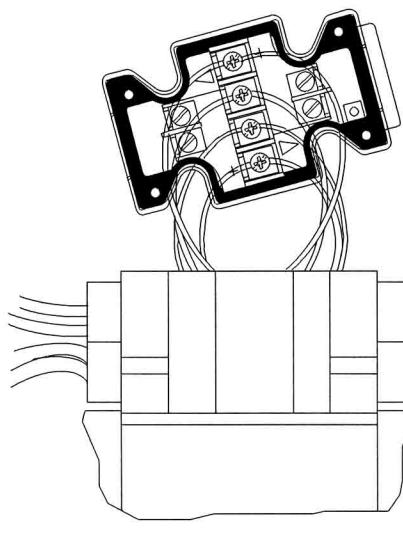

- **Scratch-proof manual override seal**

Internal seals are located such that they are beyond reach of any bore damage caused by small tools used to operate the manual override.

Result is no messy oil drips from the manual overrides.

Small diameter manual overrides prevent inadvertent operation.

**DG4V-3 – High Performance**

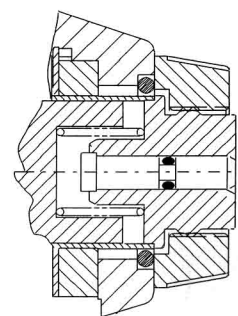

**DG4V-3S – Standard Performance**

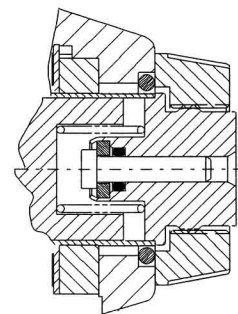

- **Surge suppression for DC valves**

Surge suppression is used to prevent coil damage by reducing contact burnoff – increasing switch life – and protecting electrical controllers from inductive spikes.

Three coil options are available:

- D1 – Encapsulated diode (Industrial application)
- D2 – Encapsulated diode (Mobile application)
- D7 – Transzorb type



## High performance DG4V-3, 6\* design Standard performance DG4V-3S, 6\* design

### Mounting interface

ISO 4401 size 03  
ANSI/B93.7M size D03  
CETOP RP65H, size 3  
DIN 24340, NG6

### Basic characteristics

Maximum pressure:  
DG4V-3                    350 bar (5075 psi)  
DG4V-3S                  350 bar (5075 psi)  
Maximum flow:  
DG4V-3                  up to 80 l/min (21 USgpm)  
DG4V-3S                up to 40 l/min (10.5 USgpm)

DG4V-3 models are direct solenoid operated four-way directional control valves. Their primary function in a hydraulic circuit is to direct fluid flow. This, in turn, would determine the direction of movement of a fluid cylinder, or the direction of rotation of a fluid motor.

Port connections are made by mounting the valve on a subplate or manifold. The valve has wet armature type solenoids.

Electrical connections to the valve are made in the electrical wiring housing or thru various plug-in connectors such as a DIN 43650 type coil

Good hydraulic design practice suggests that detented models be mounted with longitudinal axis horizontal. Other models may be mounted in any position.

### Operating considerations

1. Dependent on the application and the system filtration, any sliding spool valve if held shifted under pressure for long periods of time, may stick and not move readily due to fluid residue formation. It may therefore need to be cycled periodically to prevent this from happening.
2. Surges of fluid in a common tank line serving two or more valves can be of sufficient magnitude to cause inadvertent shifting of these valves. This is particularly critical in no-spring detented models, separate drain lines are necessary.

### Temperature limits

Minimum ambient . . . . . -20°C (-4°F)

Maximum ambient  
Valves with coils listed in model code and at stated percentages of rated voltage.

Construction of a typical single solenoid model

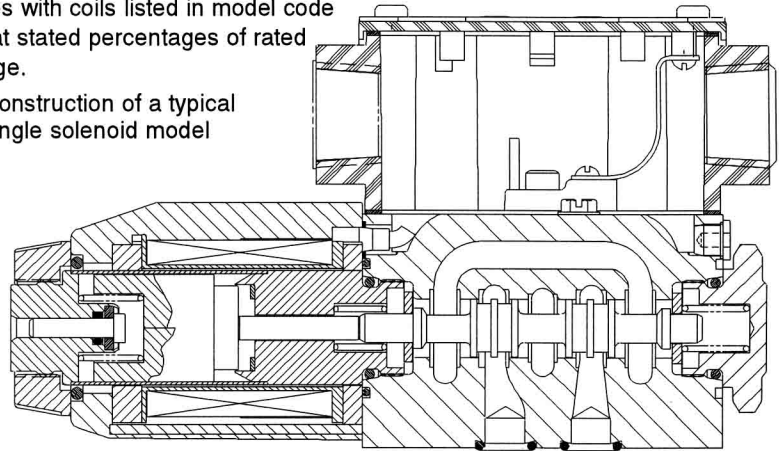

### Fluid temperature

Fluid Temp.	Mineral oil	Water-containing
Min	-20°C (-4°F)	+10°C (+50°F)
Max.*	+70°C (+158°F)	+54°C (+129°F)

\* To obtain optimum service life from both fluid and hydraulic system, 65°C (150°F) normally is the maximum temperature except for water-containing fluids.

Coil type and frequency	Percentage voltage	Maximum ambient temperature	
		DG4V-3	DG4V-3S
Dual frequency coils			
@ 50 Hz	107%	40°C (104°F)	65°C (149°F)
@ 50 Hz	110%	30°C (86°F)	65°C (149°F)
@ 60 Hz	107%	50°C (122°F)	65°C (149°F)
@ 60 Hz	110%	40°C (104°F)	65°C (149°F)
Single frequency (50 Hz) coils			
@ 50 Hz	110%	40°C (104°F)	65°C (149°F)
DC coils	110%	70°C (158°F)	70°C (158°F)

For synthetic fluids consult manufacturer or Vickers representative where limits are outside those for mineral oil.

Whatever the actual temperature range, ensure that viscosities stay within the limits specified in the "Hydraulic fluids" section.

Spool types shown represent the highest proportion of market requirements. For other spool functions that may be required, consult your Vickers sales representative.

### Solenoids identified to U.S. standards

Functional symbols related to solenoid identity "A" and/or "B" according to NFPA/ANSI standards, i.e. energizing solenoid "A" gives flow P to A, solenoid "B" gives flow P to B (as applicable).

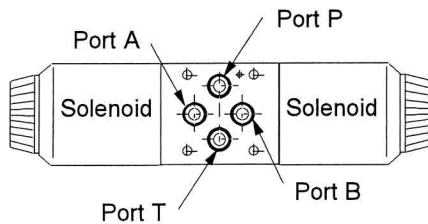

Solenoid	For spool type	Solenoid
B	All except "8"	A
A	"8" only	B

For valves with type "8" spools, solenoid identity to U.S. convention is the same as for European convention.

### Solenoids identified to European standards (specify "V" in model code)

Functional symbols related to solenoid identity "A" and/or "B" according to European convention i.e. solenoid "A" adjacent to "A" port, solenoid "B" adjacent to "B" port of valve.

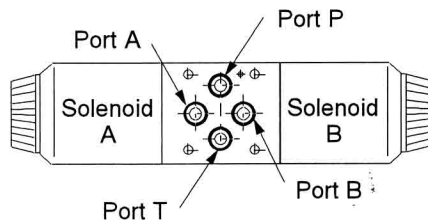

- For differences in valve function, refer to Performance Data page 11.
- ◇ F build spools.

### U.S. solenoid standard

Double solenoid valves, two position, detented

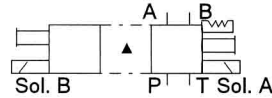

Single solenoid valves, solenoid at port A end

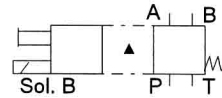

Single solenoid valves, solenoid at port B end

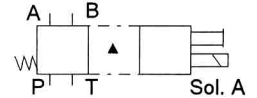

Double solenoid valves, spring centered

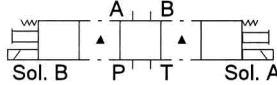

▲ Transient condition only

### The valve function schematics apply to both U.S. and European valves.

DG4V-3(S)-\*N(V)

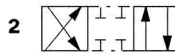

DG4V-3(S)-\*A(V)

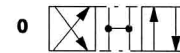

DG4V-3(S)-\*AL(V)

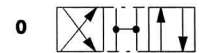

DG4V-3(S)-\*C(V)

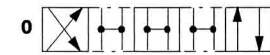

DG4V-3(S)-\*B/F(V)



DG4V-3(S)-\*BL/FL(V)

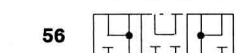
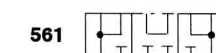
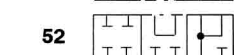
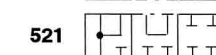
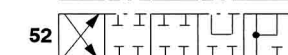
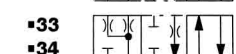
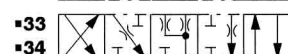
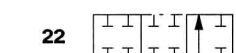
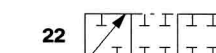
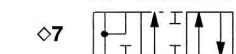
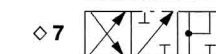
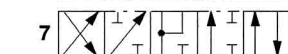
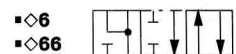
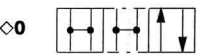

DG4V-3(S)-8C(V)

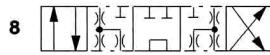

DG4V-3(S)-8BL(V)

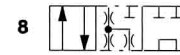

DG4V-3(S)-8B(V)

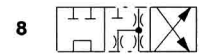

### European solenoid standard

Double solenoid valves, two position, detented

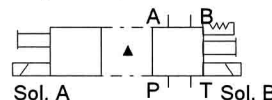

Single solenoid valves, solenoid at port A end

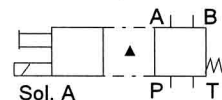

Single solenoid valves, solenoid at port B end

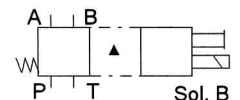

Double solenoid valves, spring centered

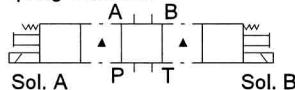

▲ Transient condition only

# Model Code

**DG4V-3(S) - \*\*\*(L)-(\*\*)-(V)M-(S\*) - \* \*\* \* D\* (L) - \*\* -6\* -(EN\*\*\*)-(P\*\*-A\*\*-B\*\*-T\*\*)**

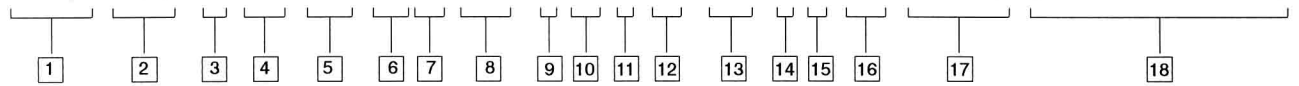

**1 Model series**

- D – Directional valve
- G – Subplate/manifold mounted
- 4 – Solenoid operated
- V – Pressure rating 350 bar (5075 psi) on P, A & B ports

**2 Standard or high performance**

- 3 – High performance specification: up to 80 l/min (21 USgpm) at 350 bar (5075 psi)
- 3S – Standard performance specification: up to 40 l/min (10.5 USgpm) at 350 bar (5075 psi)

**3 Spool type**

See “Functional symbols” section.

**4 Spool spring arrangement**

- A – Spring offset, end-to-end
- AL – Same as “A” but left hand build
- B – Spring offset, end to center
- BL – Same as “B” but left hand build
- C – Spring centered
- F – Spring offset, shift to center
- FL – Same as “F” but left hand build
- N – No-spring detented

**5 Manual override option**

- No symbol – Plain override(s) in solenoid end(s) only ▲
- H – Water-resistant override(s) on solenoid end(s) ▲
- H2 – Water-resistant override both ends of solenoid.
- P2 – Plain override both ends of single solenoid.
- Y● – Latching manual override on solenoid ends (includes “H” feature seal) ▲
- Z – No overrides at either end

▲ No override in non-solenoid end of single solenoid valves

● Not available on DG4V-3S, AC models

**6 Solenoid energization identity**

- V – Solenoid “A” is at port “A” end and/or solenoid “B” is at port “B” end, independent of spool type

Omit for U.S. ANSI B93.9 standard requiring solenoid “A” energization to connect P to A and/or solenoid “B” to connect P to B, independent of solenoid location.

*NOTE: Type “8” spool valves conform to both U.S. and European solenoid designations. When ordering an “8” spool, designate a “V” in the model code.*

**7 Flag symbol**

- M – Electrical options and features

**8 Spool indicator switch**

*Available on high performance models, DG4V-3, only. Omit when not required.*

DG4V-3-\*A(L)-(V)M models with type U (ISO4400) electrical connector to solenoid; spool type 0, 2 or 22 only: S6 – LVDT type DC switch with Pg7 connector plug.

DG4V-3-\*A(L)-(Z)-(V)M-S\*-FPA5W valves with mechanical type AC (~) switch, wired to 5-pin receptacle: S3 – Switch, wired normally open S4 – Switch, wired normally closed

DG4V-3-\*A(L)-(Z)-(V)M-S5-F(T)W/J valves with mechanical type AC (~) switch: S5 – Switch, free leads

**9 Coil type**

- U – ISO 4400 (DIN 43650) mounting◆
- U1 – Connector fitted
- U6 – Connector fitted w/lights
- U11 – Connector fitted w/rectifier & lights\*\*
- U12 – Connector fitted w/rectifier\*\*
- F – 1/2" NPT thread conduit box
- KU – Top exit flying leads\*
- SP1 – Single 6,3 mm spade◆
- SP2 – Dual 6,3 mm spade◆
- X1 – Flame resistant solenoids TP EEx-d-11B-T4
- X2 – Hazardous location solenoids to meet UL & CSA approval
- X3 – Special protection solenoids to BASEEFA standar SFA009:1972, protection class EX-S-11-T4

◆ Female connector to be supplied by customer  
 \* DC service only  
 \*\* AC service only

**10 Electrical connector**

- T – Wired terminal block
- PA – Instaplug male receptacle only
- PB – Instaplug male & female receptacle
- PA3 – Three pin connector
- PA5 – Five pin connector

**11 Housing (F type coils only)**

- W – 1/2" NPT thread wiring housing
- J – 20 mm thread wiring housing

**12 Surge suppressor/damper**

- D1 – Encapsulated diode (Industrial applications)
- D2 – Encapsulated diode (Mobile applications)
- D7 – Transzorb type (F,KU,U,SP1,SP2 only)

**13 Solenoid indicator lights**

*Not available on PA, KU, U, SP1 & SP2*

**14 Coil rating**

- Full power coils, see “Operating Data”.
  - A – 110V AC 50Hz
  - B◇ – 110V AC 50Hz/120V AC 60 Hz
  - C – 220V AC 50 Hz
  - D◇ – 220V AC 50 Hz/240V AC 60 Hz
  - G – 12V DC
  - H – 24V DC

For DG4V-3 only (not usable with DG4V-3S):

- Low power coils, see “Operating Data”. (Not available with “N” – No-spring detented models)
  - BL – 110V 50 Hz/120V 60 Hz
  - DL – 220V AC 50 Hz/240V AC 60 Hz
  - GL – 12V DC
  - HL – 24V DC

◇ For 60 Hz or dual frequency

*Contact your Vickers representative for additional coil voltage options*

**15 Port T code**

- Refer to “Operating Data” for port T pressure ratings.
  - 2 – 10 bar (150 psi) for spool position indicator models S3, S4 and S5.
  - 4 – 70 bar (1000 psi)
  - 5 – 100 bar (1500 psi) for standard performance models, DG4V-3S, with AC or DC solenoids.
  - 6 – 207 bar (3000 psi) for AC high performance models, DG4V-3, including spool position indicator type S6.
  - 7 – 207 bar (3000 psi) for DC high performance models, DG4V-3, including spool position indicator type S6.

**16 Design number**

- 60 – Basic design
- 61 – Type 8 spool

**17 Special features**

“EN\*\*\*” code number assigned as required.  
 EN21 – CSA approved models with 1/2" NPT entry conduit box, type FW and solenoid coil letter B,D,G, or H.

**18 Port restrictor plugs**

For details of plug orifice sizes and how to specify in model code see page 15. May be fitted to valves by agreement with your Vickers representative.  
 Omit – No restrictor plugs fitted



# Operating Data



Performance data is typical with fluid at 36cSt (168 SUS) and 50°C (122°F).

Feature	Standard performance valve DG4V-3S		High performance valve DG4V-3	
Pressure limits: P, A and B ports T port: Spool indicator switch models Types S3, S4, S5 Type S6 All other models	350 bar (5075 psi) ■		350 bar (5075 psi)	
	N/A		10 bar (145 psi)	
	N/A		210 bar (3045 psi)	
	100 bar (1450 psi)		210 bar (3045 psi)	
Flow rating	See performance data		See performance data	
Relative duty factor	Continuous; ED = 100%		Continuous; ED = 100%	
Type of protection: ISO 4400 coils with plug fitted correctly SP1 – Single spade 6,3 mm SP2 – Dual spade 6,3 mm Coil winding Lead wires (coils type F***) Coil encapsulation	IEC 144 class IP65 IEC 760 IEC 760 Class H Class H Class F		IEC 144 class IP65 IEC 760 IEC 760 Class H Class H Class F	
Permissible voltage fluctuation: Maximum Minimum	Refer to temperature limits. 90% rated		Refer to temperature limits. 90% rated	
Typical response times at 100% rated volts measured from application/removal of voltage to full spool displacement of "2C" spool at: Flow rate P-A, B-T Pressure AC (~) energizing AC (~) de-energizing DC (=) energizing DC (=) de-energizing	20 l/min (5.3 USgpm) 175 bar (2537 psi) 18 ms 32 ms 60 ms 40 ms		40 l/min (10.6 USgpm) 175 bar (2537 psi) 15 ms 23 ms 45 ms 28 ms	
Power consumption, AC solenoids (for coils listed in model code).	Initial ▲ VA (RMS)	Holding VA (RMS)	Initial ▲ VA (RMS)	Holding VA (RMS)
Full power coils: Single frequency coils AC 50 Hz Dual frequency coils at 50 Hz Dual frequency coils at 60 HZ	225 265 260	39 49 48	265 280 300	54 61 58
Low power coils, "BL" and "DL": (Not available with "N" – No-spring detented models) Dual frequency coils at 50 Hz Dual frequency coils at 60 Hz	Low power coils not usable with DG4V-3S valves.		170 190	37 37
Power consumption, DC solenoids at rated voltage and 20°C (68°F).				
Full power coils: 12V, model type "G" 24V, model type "H"	30W 30W	– –	30W 30W	– –
Low power coils: 12V, model type "GL" 24V, model type "HL"	Low power coils not usable with DG4V-3S valves.		18W 18W	– –

■ For applications where valves are to remain pressurized (either energized or de-energized) at pressures over 210 bar (3045 psi) without frequent switching, it is recommended to use the high performance model, DG4V-3.

▲ 1st half cycle; armature fully retracted.



# Performance Data



Typical with mineral oil at 36 cSt (168.6 SUS) and a specific gravity of 0.87.

### Maximum flow rates

Performance based on full power solenoid coils warm and operating at 90% rated voltage.

See note at bottom of next page when using low power coils (DG4V-3 models only).

## DG4V-3S models (standard performance)

Graph 1  
AC solenoid valves with dual frequency coils operating at 50 Hz

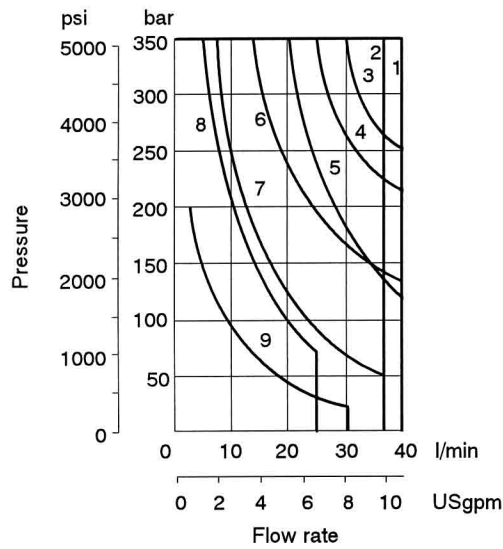

Graph 2  
AC solenoid valves with  
- Dual frequency coils operating at 60 Hz  
- Single frequency (50 Hz) coils operating at 50 Hz

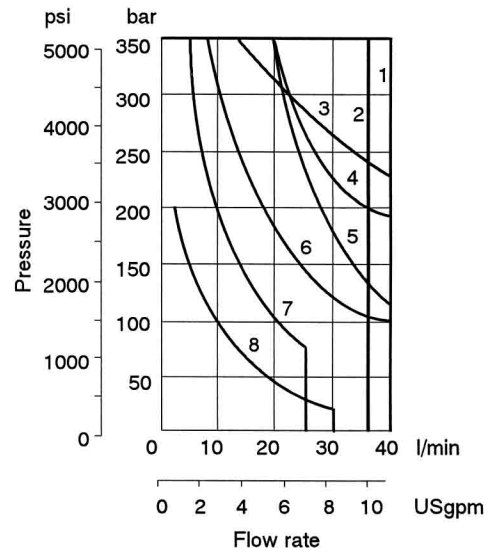

Graph 3  
DC solenoid valves

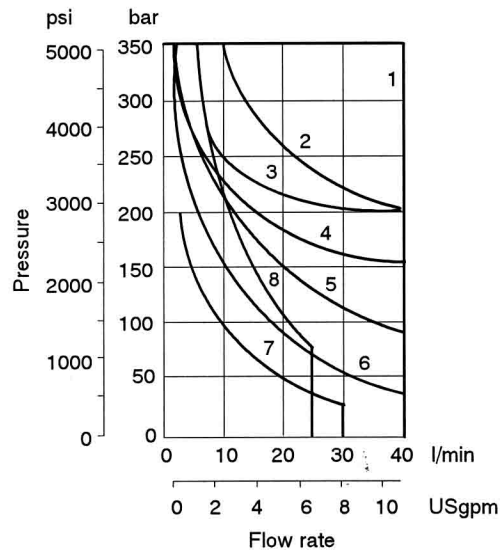

Spool/spring code	Graph 1 curve	Graph 2 curve	Graph 3 curve
0A(L)	1	1	3
0B(L) & 0C, 0F	1	1	1
2A(L)	5	5	3
2B(L) & 2C, 2F	2	2	3
2N	1	1	1
6B(L) & 6C, 6F	6	6	5
7B(L) & 7C, 7F	6	6	2
8B(L) & 8C	8▲	7▲	8▲
22A(L)	9	8	7
22B(L) & 22C	7	7	6
24A(L)	6	6	5
33B(L) & 33C	4	4	4
34B(L) & 34C	6	6	5
52BL, 52C, 56BL & 56C	6	6	5
66B(L) & 66C	3	3	5
521B & 561B	6	6	5

▲ Consult Vickers regarding each application that will jointly have flow rates approaching this curve and a pressurized volume exceeding 2000 cm<sup>3</sup> (122 cu.in.)





# Performance Data

## Pressure drops

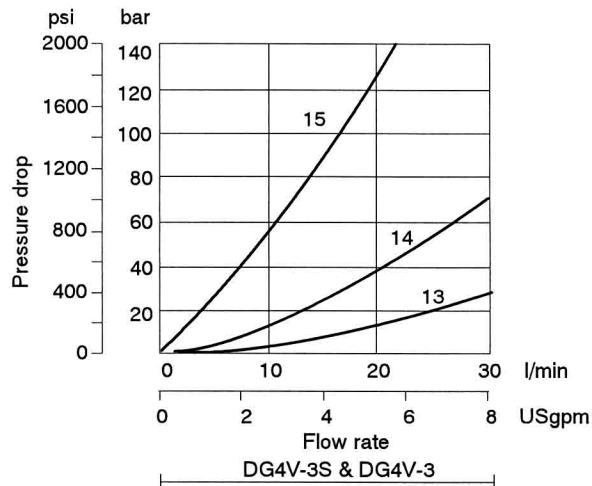
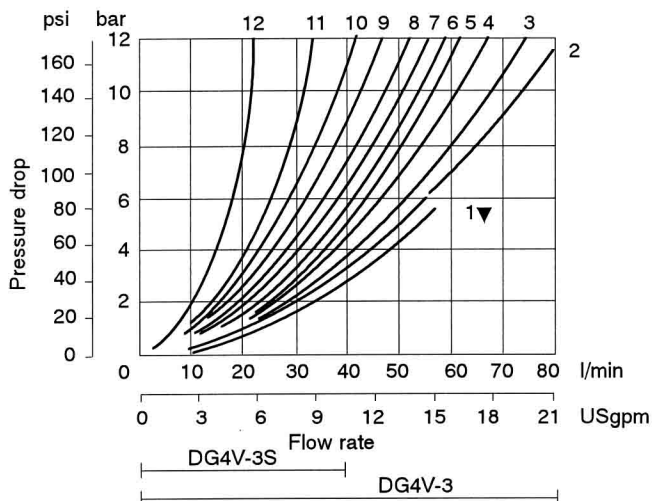

▼ Curve for spool type 6: not recommended for flows in excess of 60 l/min (15.8 USgpm).

## Pressure drops in offset positions except where otherwise indicated

Spool/spring code	Spool positions covered	P to A	P to B	A to T	B to T	P to T	B to A or A to B
0A(L)	Both	5	5	2	2	-	-
0B(L) & 0C, 0F	De-energized	-	-	-	-	4▲▲	-
	Energized	4	4	2	2	-	-
2A(L)	Both	6	6	5	5	-	-
2B(L) & 2C, 2F	Energized	5	5	2	2	-	-
2N	Both	6	6	3	3	-	-
6B(L) & 6C, 6F	De-energized	-	-	3▲	3Δ	-	-
	Energized	6	6	1	1	-	-
7B(L) & 7C, 7F	De-energized	6▲	6Δ	-	-	-	7○
	Energized	4	4	3	3	-	-
8B(L) & 8C	All	9	9	5	5	3	-
22A(L), 22B(L) & 22C	All	6	6	-	-	-	-
24A(L)	De-energized	6	6	2	2	-	-
33B(L) & 33C	De-energized	-	-	15▲	15Δ	-	-
	Energized	5	5	2	2	-	-
34B(L) & 34C	De-energized	-	-	14▲	14Δ	-	-
	Energized	5	5	2	2	-	-
52BL & 52C	Energized	6▲	6Δ	2	-	-	10○
56BL	Both	6▲	6Δ	11▲	10Δ	-	10○
56C	De-energized	-	-	11▲	10Δ	-	10○
	Energized	6▲	6Δ	2	-	-	10○
66B(L) & 66C	De-energized	-	-	12	12	-	13
	Energized	6	6	2	2	-	-
521B	All	6▲	6Δ	-	-	-	10○
561B	De-energized	-	-	10▲	11Δ	-	10○
	Energized	6	6Δ	-	-	-	10○

▲ "B" plugged    Δ "A" plugged    ○ "P" plugged

For other viscosities, pressure drops approximate to:

Viscosity cSt (SUS)

14	20	43	54	65	76	85
(17.5)	(97.8)	(200)	(251)	(302)	(352)	(399)

% of Δp

81	88	104	111	116	120	124
----	----	-----	-----	-----	-----	-----

A change to another specific gravity will yield an approximately proportional change in pressure drop.

The specific gravity of a fluid may be obtained from its producer. Fire resistant fluids usually have higher specific gravities than oil.



# Installation Dimensions

## Models for use with ISO 4400 (DIN 43650) connectors

Double solenoid models ▲  
 DG4V-3(S)-\*C-\*\*-\*(V)M-U-\*\*-60  
 DG4V-3(S)-\*N-\*\*-\*(V)M-U-\*\*-60

Single solenoid models ▲  
 DG4V-3(S)-\*A-\*\*-\*(S) ■  
 DG4V-3(S)-\*B-\*\*-\*(S) ■  
 DG4V-3(S)-8BL-\*\*-\*(S) ■  
 DG3V-3(S)-\*F-\*\*-\*(S) ■

As shown }  
 DG4V-3(S)-\*AL-\*\*-\*(S) ■  
 DG4V-3(S)-\*BL-\*\*-\*(S) ■  
 DG4V-3(S)-8B-\*\*-\*(S) ■  
 DG4V-3(S)-\*FL-\*\*-\*(S) ■

} Solenoid and end cap interchangeable



Dim mm (in.)

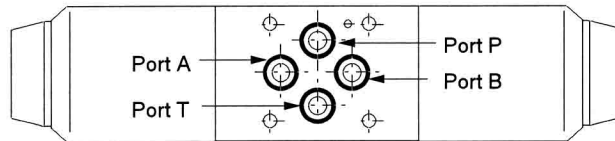
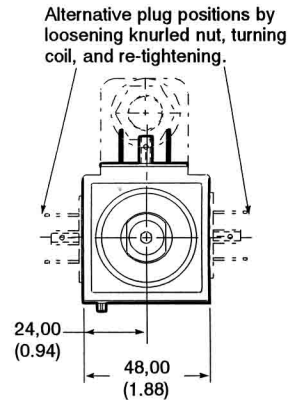
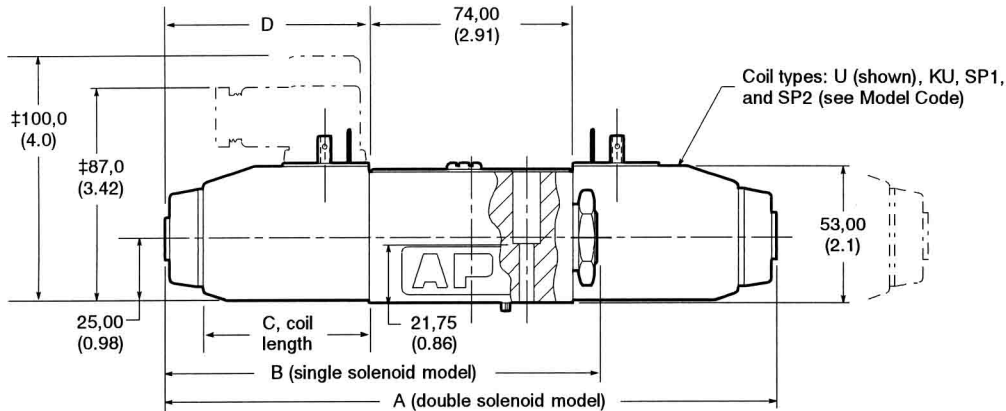

■ Not applicable to type "8" spool.

▲ See page 25 for solenoid information.

‡ Can vary dependent on source of plug.

Model type	AC or DC	A Dim.	B Dim.	C Dim.	D Dim.
All	DC =	220 (8.66)	156 (6.14)	61 (2.5)	73 (2.87)
DG4V-3	AC ~	200 (7.87)	146 (5.75)	51 (2.1)	63 (2.48)
DG4V-3S	AC ~	200 (7.87)	146 (5.75)	45 (1.7)	63 (2.48)

## Water-resistant manual override on solenoid

DG4V-3(S)-\*\*\*\*(L)-H-(V)M-\*\*-\*\*-60

### Application

General use where finger operation is required (standard manual overrides cannot be operated without using small tool).

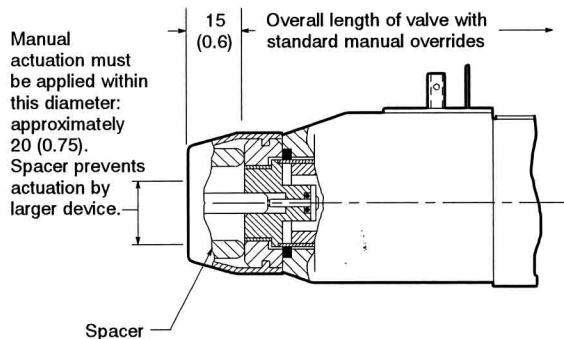

Note:

"H" feature is not field convertible from other models; specify with order.

## Latching manual override on solenoid

DG4V-3-\*\*\*\*(L)-Y-(V)M-\*\*-\*\*-60

DG4V-3S-\*\*\*\*(L)-Y-(V)M-\*\*-\*\*-60, DC coil models only

### Application

Stainless steel lever/latch mechanism and water-resistant seal make this feature ideal for vehicle-mounted and exposed applications requiring emergency selection of valve for a period of time in the event of electrical failure.

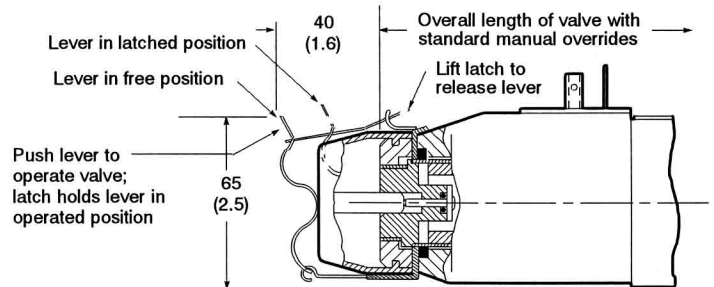

Notes:

1. Opposite solenoid (on "C" and "N" double solenoid models) should not be energized while the valve is latched in selected position; AC solenoid coils will burn out under this improper usage.
2. "Y" feature is field-convertible from "H" type manual override (omitting spacer), but is not field-convertible from other models.

# Installation Dimensions

## Mounting Surface

Dimensions shown in mm (inches ▲)

When a subplate is not used, a machined pad must be provided for mounting. The pad must be flat within 0,01 mm per 100 mm (0.0001" per 1") and smooth within 0,8 μm (32 μin).

The interface conforms to ISO 4401-AB-03-4A (size 03) plus location pin hole  
ANSI/B93.7M (and NFPA) size 03  
CETOP R35H4.2-03, plus location pin hole  
DIN 24340 Form A6, plus location pin hole

Dimensional tolerance =  $\pm 0,2$  ( $\pm 0.008$ ) except where otherwise stated.

Prior to installing a valve, ensure that both valve and mounting surface are clean and free from burrs.

▲ ISO 4401 gives dimensions in mm. Inch conversions are accurate to 0.01" unless stated.

■ #10-24 UNC-2B optional

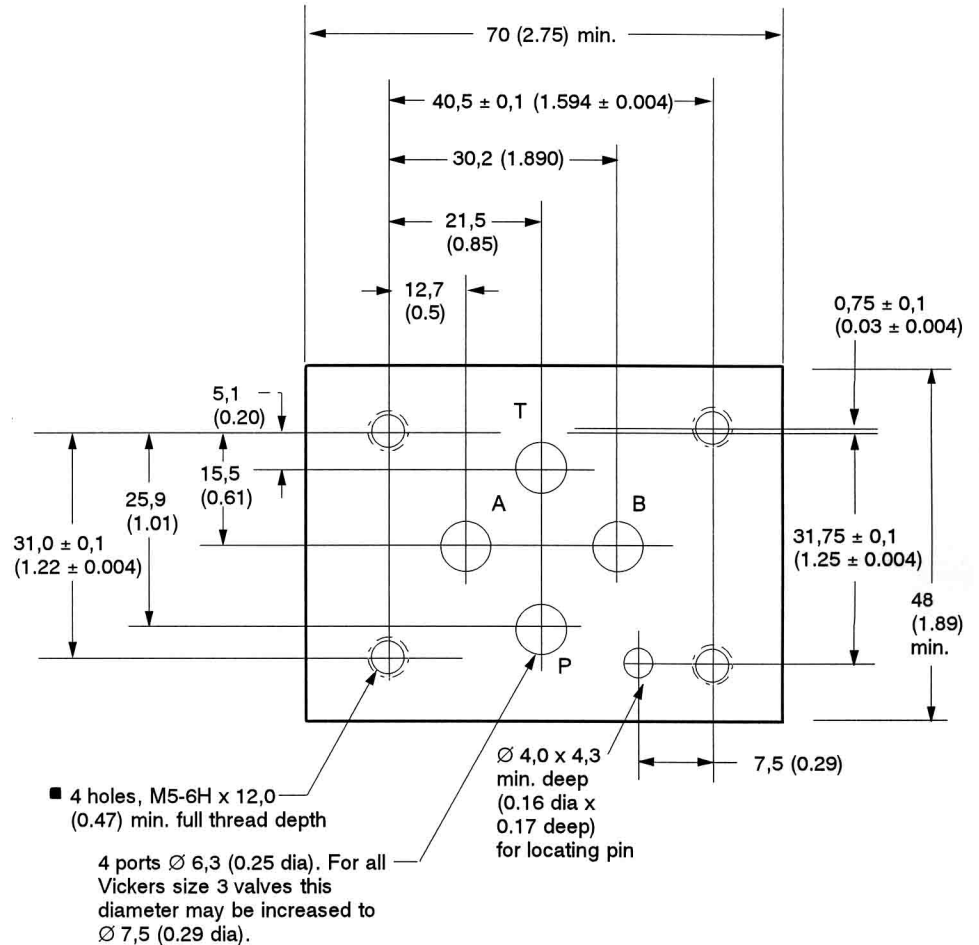



## Spare parts data

Refer to service drawing I-3886-S for spare parts and kit information.

### Seal kits

For valves with spool indicator switch, model types DG4V-3-\*A---M-S\*---60  
..... kit no. 859049

For other models seal kits vary according to type of coil fitted:

For "U" type coil ..... kit no. 858995

For "F" type coil ..... kit no. 858996

*Note: Each seal kit covers a variety of models and may have redundant seals for a particular model.*

## Solenoid Coils

### AC coils

Code	Voltage/ frequency	Standard performance		High performance	
		"U" type	"F" type	"U" type	"F" type
Full power coils:					
A	110V/50 Hz	02-101725	02-101730	507825	508166
B	110/120V/50/60 Hz	02-101726	02-101731	507833	508169
C	220V/50 Hz	02-101727	02-101732	507826	508167
D	220/240V/50/60 Hz	02-101728	02-101733	507834	508170
Low power coils:					
BL	110/120V/50/60 Hz	N/A	N/A	598562	698563
DL	220/240V/50/60 Hz	N/A	N/A	866455	866457

### DC coils (Standard and high performance)

Code	Voltage	"U" type	"F" type	"SP1" type	"SP2" type	"KU" type
Full power coils:						
G	12V	507847	508172	02-111246	02-111166	02-140394
H	24V	507848	508173	02-111248	02-111168	02-140395
Low power coils:						
GL	12V	507855	508175	N/A	N/A	N/A
HL	24V	507852	508174	N/A	N/A	N/A

## Mass, approx. kg (lb)

DG4V-3 and DG4V-3S (DC)	"U" coils	"F" coils
Single sol. valve	1,6 (3.5)	1,8 (4.0)
Double sol. valve	2,2 (4.8)	2,3 (5.0)
DG4V-3 and DG4V-3S (AC)	"U" coils	"F" coils
Single sol. valve	1,5 (3.3)	1,6 (3.5)
Double sol. valve	1,8 (4.0)	2,0 (4.4)
Single sol. valve w/ position switch	2,0 (4.4)	2,0 (4.4)

## Mounting Attitude

No restrictions except for no-spring, detented models DG4V-3-\*N and DG4V-3S-\*N which should be mounted with the spool axis horizontal. These model types may be affected by severe vibration or shock, especially if a solenoid is not held energized.



## Temperature Limits

Ambient range . . . . -20°C to 70°C  
(-4°F to +158°F)

## Fluid Temperature

Fluid Temp.	Mineral oil	Water containing
Minimum	-20°C (-4°F)	+10°C (+50°F)
Maximum*	+70°C (+158°F)	+54°C (+129°F)

\* To obtain optimum service life from both fluid and hydraulic system, 65°C (150°F) is the recommended maximum fluid temperature, except for water-containing fluids.

For synthetic fluids, consult fluid manufacturer or Vickers representative where limits are outside those for mineral oil.

Whatever the actual temperature range, ensure that fluid viscosities stay within the limits specified in "Hydraulic Fluids".

## Fluid Cleanliness

Proper fluid condition is essential for long and satisfactory life of hydraulic components and systems. Hydraulic fluid must have the correct balance of cleanliness, materials and additives for protection against wear of components, elevated viscosity and inclusion of air.

Essential information on the correct methods for treating hydraulic fluid is included in Vickers publication 561; "Vickers Guide to Systemic Contamination Control," available from your local Vickers distributor or by contacting Vickers, Incorporated. Recommendations on filtration and the selection of products to control fluid condition are included in 561.

Recommended cleanliness levels, using petroleum oil under common conditions, are based on the highest fluid pressure levels in the system and are coded in the chart below. Fluids

other than petroleum, severe service cycles or temperature extremes are cause for adjustment of these cleanliness codes. See Vickers publication 561 for exact details.

Vickers products, as any components, will operate with apparent satisfaction in fluids with higher cleanliness codes than those described. Other manufacturers will often recommend levels above those specified.

Experience has shown, however, that life of any hydraulic components is shortened in fluids with higher cleanliness codes than those listed below. These codes have been proven to provide a long trouble-free service life for the products shown, regardless of the manufacturer.

Fire resistant fluids usually have higher specific gravities than oil. The specific gravity of a fluid may be obtained from its producer.

Product	System Pressure Level		
	bar (psi)		
	<70 (<2000)	70-207 (2000-3000)	207+ (3000+)
Vane pumps, fixed	20/18/15	19/17/14	18/16/13
Vane pumps, variable	18/16/14	17/15/13	
Piston pumps, fixed	19/17/15	18/16/14	17/15/13
Piston pumps, variable	18/16/14	17/15/13	16/14/12
Directional valves	20/18/15	20/18/15	19/17/14
Proportional valves	17/15/12	17/15/12	15/13/11
Servo valves	16/14/11	16/14/11	15/13/10
Pressure/Flow controls	19/17/14	19/17/14	19/17/14
Cylinders	20/18/15	20/18/15	20/18/15
Vane motors	20/18/15	19/17/14	18/16/13
Axial piston motors	19/17/14	18/16/13	17/15/12

## Ordering Procedure

When placing an order, please specify full model designations of valves, subplates and kits. Refer to relevant "Model Code" sections.



## D03 Cover Plates

### Parallel Circuit Cover Plate

Cover Plate mounting hardware is supplied.  
See page 44 for itemized list.

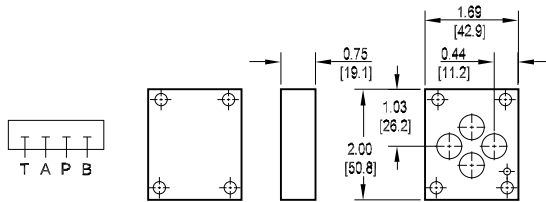

### Parallel Circuit Cover Plate with Gauge Port

Cover Plate mounting hardware is supplied. \*  
See page 44 for itemized list.  
\* Plug not supplied for metric gauge port.

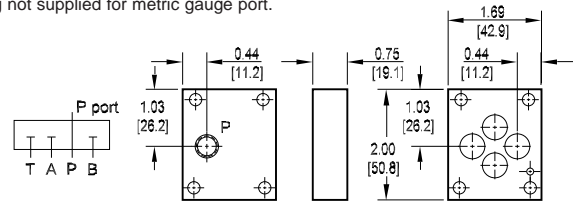

### Series Circuit Cover Plate: P to T

Cover Plate mounting hardware is supplied.  
See page 44 for itemized list.

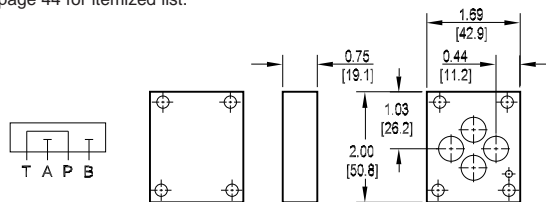

### Crossover Cover Plate: P to A; B to T

Cover Plate mounting hardware is supplied.  
See page 44 for itemized list.

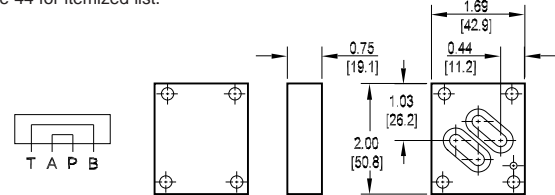

Specifications, descriptions, and dimensional data are subject to correction or change without notice or incurring obligation.

2

## Ordering Information

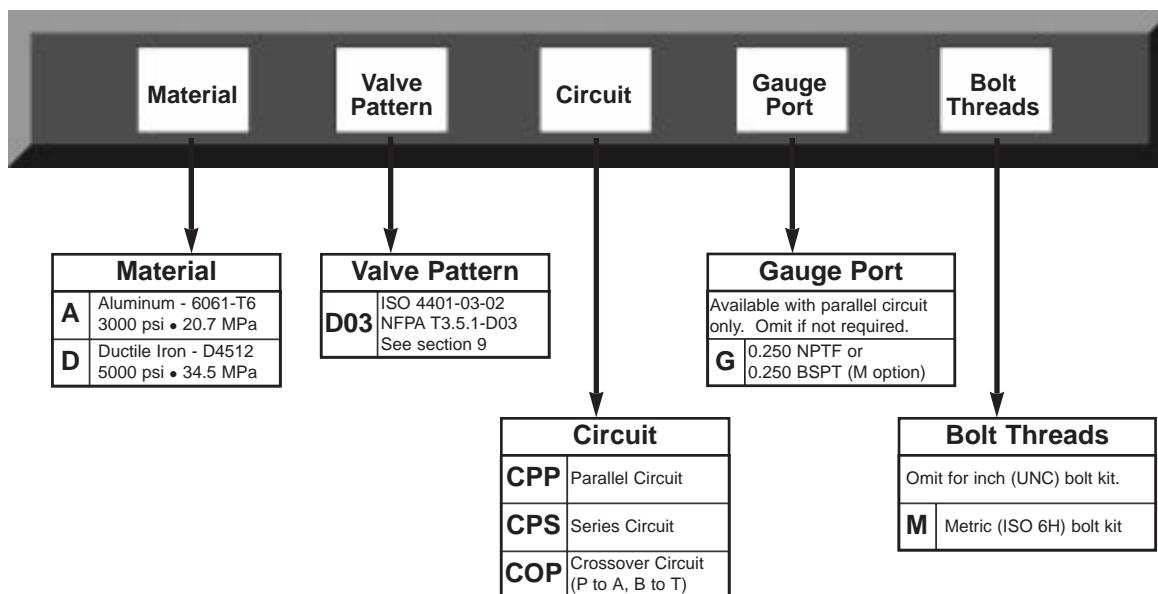

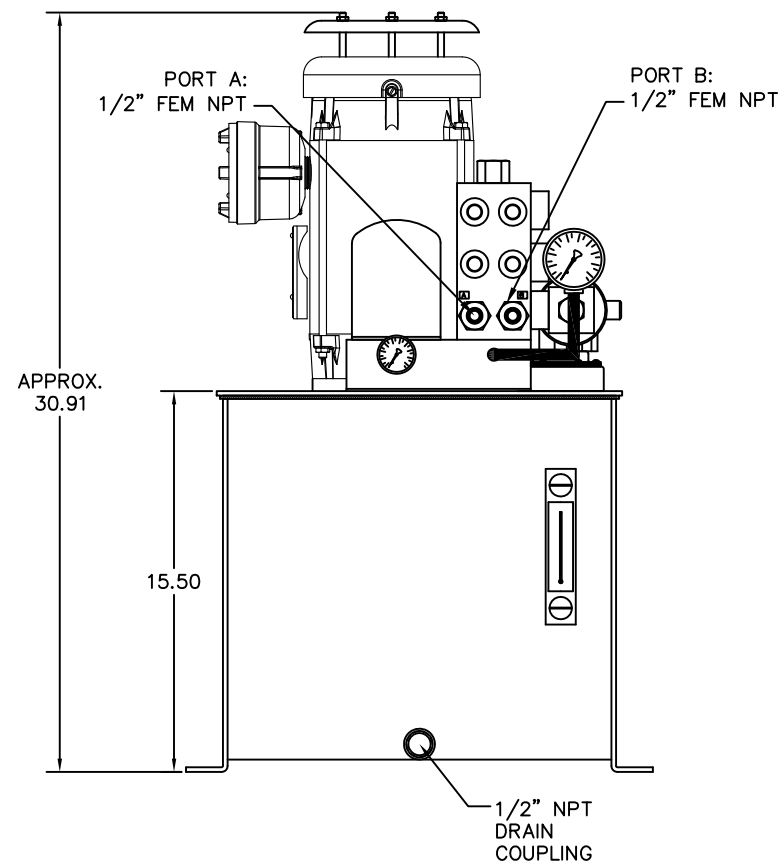
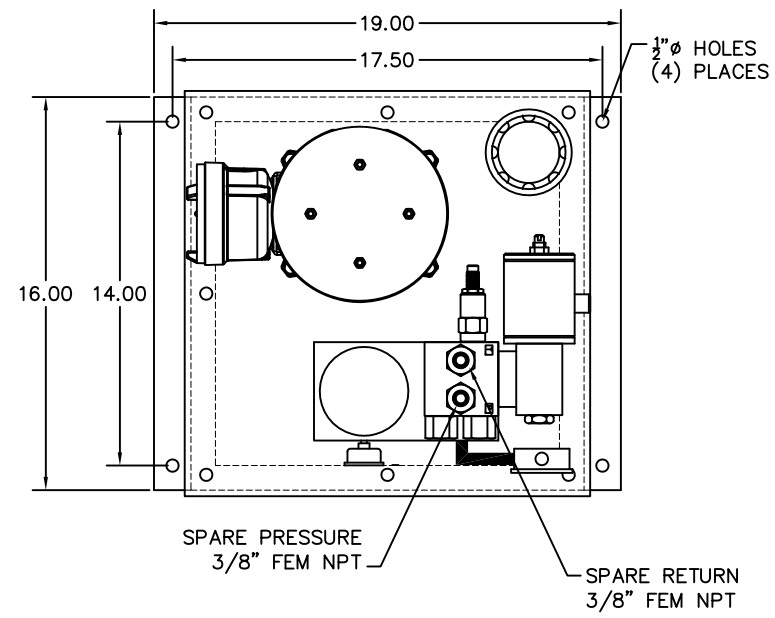

CONSTRUCTION NOTE:  
MOUNT THE MANIFOLD ASSEMBLY WITHIN  
THE TANK ENVELOPE AS MUCH AS POSSIBLE

1	12/22/16	DCS	AS BUILT
0	11/28/16	DCS	ISSUED FOR CONSTRUCTION
A	11/10/16	DCS	ISSUED FOR APPROVAL
NO.	DATE	BY	REVISION

THIS DOCUMENT CONTAINS PROPRIETARY INFORMATION AND SUCH INFORMATION MAY NOT BE DISCLOSED TO OTHERS FOR ANY PURPOSE OR USED FOR MANUFACTURING PURPOSES WITHOUT WRITTEN PERMISSION FROM SUNSOURCE. AND SHALL BE RETURNED WHEN REQUESTED.

<b>SUNSOURCE</b> Fluid Power Systems			
COMPANY <b>CAMERON (JISKOOT)</b>			
DRAWING NAME POWER UNIT GENERAL ARRANGEMENT (SINGLE STATION)			
DRAWN BY D. SCHURGER	DATE 11/10/16	DRAWING NO. N122AGA	
DESIGNED BY SUNSOURCE	SCALE 1:4	CUSTOMER PART NO. 76537067	
CHECKED BY B. MURROW	SHEET 1 OF 1	V/A NO. 309259	REV 1



MATERIALS			
ITEM	QTY.	DESCRIPTION	PART #
1	1	RESERVOIR	SUNSOURCE LI47ATA
2	1	SIGHT/LEVEL/TEMP GAUGE	DONALDSON P562448
3	1	FILLER BREATHER	DONALDSON P562603
4	1	ELECTRIC MOTOR	BALDOR CEM7014T-I-5 (575/3/60)
-	-	1HP, 1760RPM, 3PH, 60HZ, 143TC, 3519M, XPFC, F1, CLASS 1, GROUP C & D, DIV 1	
4.1	1	MOTOR COVER	BALDOR 35FH5000A04SP
5	1	PUMP/MOTOR ADAPTER	VESCOR 150499 W/ GASKET 268599
6	1	L-070 COUPLING ASSEMBLY	VESCOR 10426/10424/25308
7	1	VANE PUMP	VICKERS V101P2P1C20
8	1	SUCTION STRAINER	ZINGA SS10003
9	1	MANIFOLD	HYDRO-CRAFT PME-2667A-3
10	1	RELIEF VALVE CARTRIDGE	VICKERS RV1010S05/
11	1	FILTER ELEMENT	DONALDSON P551551
12	1	CHECK VALVE CARTRIDGE	PARKER D04B2-2.1N
13	1	FILTER INDICATOR	HYDRO-CRAFT HCRS-30D
14	1	PRESSURE GAUGE (0-400 PSI)	WIKA 9692058
15	1	GAUGE SHUTOFF	DELTROL NMF20BK
16	1	3-STATION D03 MANIFOLD	HYDRO-CRAFT PME-3030A
17	1	SOLENOID DIRECTIONAL VALVE	EATON VICKERS DG4V3S2AMX2ER460 (120V AC)
18	2	D03 COVER PLATE	DAMAN AD03CPP
19	1	STAINLESS TAG (SET @ 115 PSI)	SUNSOURCE LI47ATG

**BUILD NOTES:**

P & T PORTS - 3/8" NPT ADAPTERS  
 A AND B CYLINDER PORTS - 1/2" NPT ADAPTERS  
 ATTACH STAINLESS STEEL TAG TO HPU

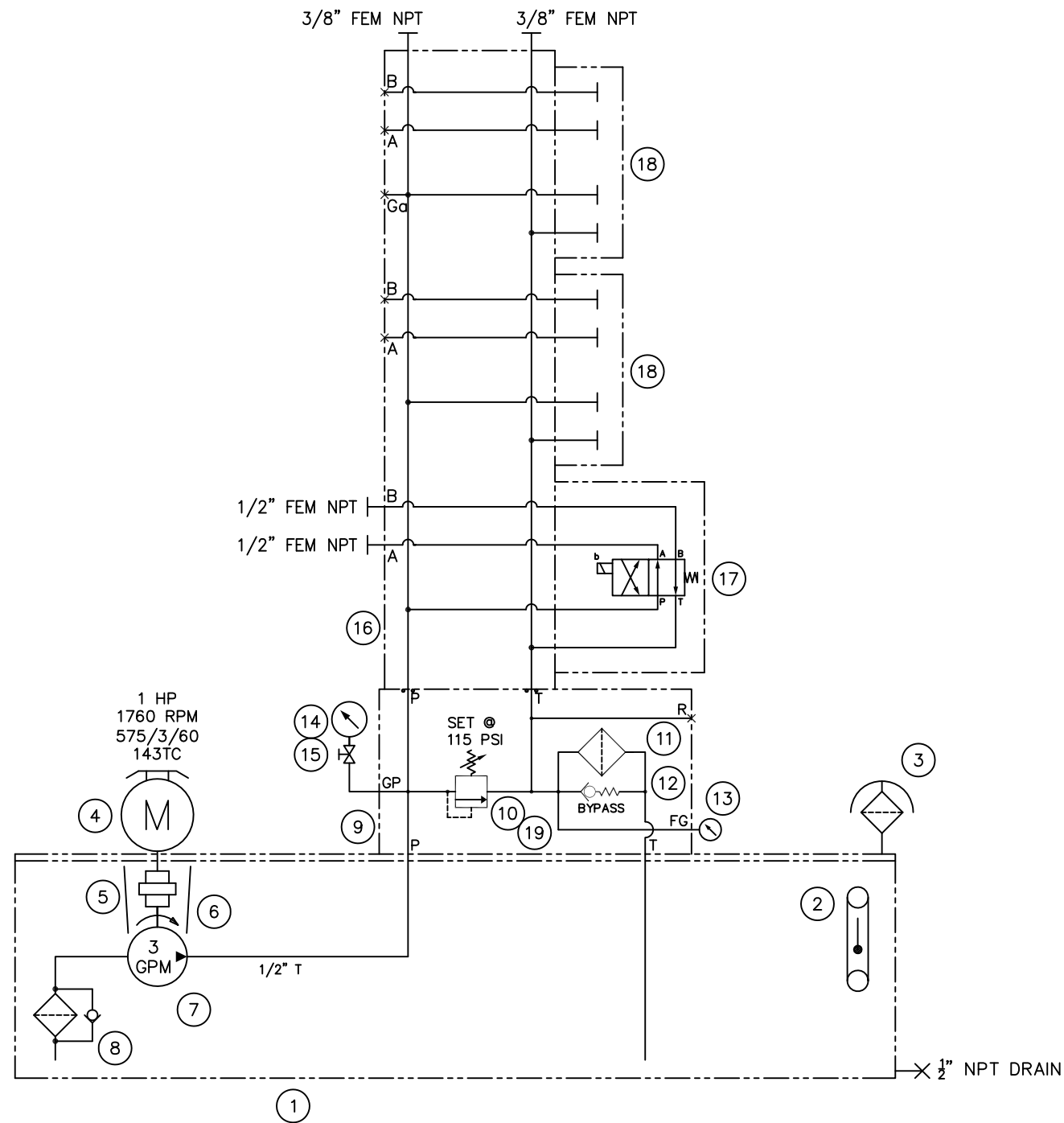

PAINT: SUNSOURCE BLUE ENAMEL  
 FITTINGS: CARBON STEEL; JIC AND ORB  
 FLUID: PETROLEUM BASE OIL FOR TEST



COMPANY		CAMERON (JISKOOT)	
DRAWING NAME HYDRAULIC POWER UNIT SCHEMATIC			
DRAWN BY D. SCHURGER	DATE 11/10/16	DRAWING NO. NI22AHC	
DESIGNED BY SUNSOURCE	SCALE NONE	CUSTOMER PART NO. 76537067	
CHECKED BY B. MURROW	SHEET 1 OF 1	V/A NO. 309259	REV 1

NO.	DATE	BY	REVISION
1	12/22/16	DCS	AS BUILT
0	11/28/16	DCS	ISSUED FOR CONSTRUCTION
A	11/10/16	DCS	ISSUED FOR APPROVAL

THIS DOCUMENT CONTAINS PROPRIETARY INFORMATION AND SUCH INFORMATION MAY NOT BE DISCLOSED TO OTHERS FOR ANY PURPOSE OR USED FOR MANUFACTURING PURPOSES WITHOUT WRITTEN PERMISSION FROM SUNSOURCE AND SHALL BE RETURNED WHEN REQUESTED.



8 7 6 5 4 3 2 1

8 7 6 5 4 3 2 1

D

C

B

A

D

C

B

A