



**Barton® MODEL 306
Flotrac® Meter**

Installation Manual

Version 01E10c
ID#10360
5/2001

CONTENTS

Section 1 - Introduction	Page 1
Specifications	Page 2
Section 2 - Installation/Operation	Page 3
Section 3 - Maintenance/Calibration/Rapair.....	Page 5
Calibration	Page 6
Repair	Page 9
Conversion to M380.....	Page 11
Section 4 - Install/Dimensional Drawings.....	Page 12
Section 5 - Parts Drawing/List:	
M306	Page 14
M380	Page 17

SECTION 1 - INTRODUCTION

General

The Barton Model 306 Flotrac uses a “constrained vortex” principle to meter high pressure, non-viscous liquids accurately and efficiently over a broad range. The water or liquid being metered may contain some abrasive and corrosive materials destructive to other types of meters. The rotor, shaft, and register gearing are the only moving parts in the Flotrac meter.

The housing is epoxy-coated cast steel. The rotor and housing inserts are Ryton R4, practically impervious to dissolved salts and alkalies, water and most acids. A magnetic coupling rotor to register eliminates packing and leakage and has a fail-safe device to prevent register “blow up” in high pressure service. The rotor bearings and journals are of special materials providing exceptional service life with water or non-lubricating liquids.



Before installing this instrument, become familiar with the installation instructions in Section 2. WARNING notes that appear on the following pages of this manual should be reviewed before proceeding: 5 and 11.

WARNING notes indicate the presence of a hazard which can cause severe personal injury, death, or substantial property damage if warning is ignored.

In-line examination of all parts exposed to the process liquid is simple. First depressurize the meter. Then by unscrewing six cap screws and removing the meter cover, the rotor can be slipped off for inspection or replacement.

Specifications

Operating Pressure Range	5000 psig SWP 7500 psig Test
Capacity	10 to 90 GPM
Operating Temperature Range	32°F to 200°F
Accuracy	±1.0% of reading over 9:1 flow range
Pipe Connections	1" female NPT, inline
Register	eight digits U.S. Barrels: 1/100 Liters: 1 Cubic Meters: 1/1000
Weight	22 lb
Overall Dimensions (with register):	
Length	8.75 inches
Width	5.75 inches
Height	6.0 inches

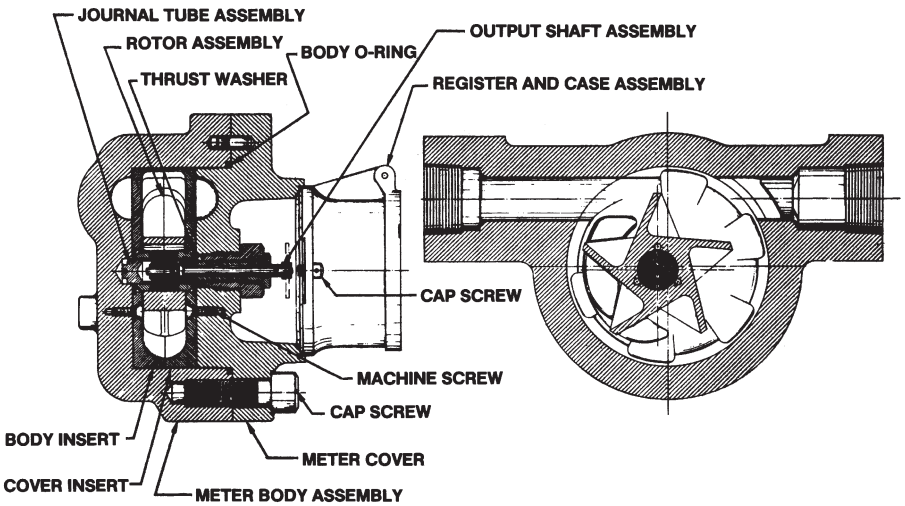

M306 Cross-section View

SECTION 2 - INSTALLATION/OPERATION

General

The instrument should be inspected at time of unpacking to detect any damage that may have occurred during shipment.

Pre-check

The Model 306 Flotrac Meter was calibrated at the factory on clean water before shipment. If further calibration is required, contact the nearest Cameron representative

Mounting

1. Piping - The meter has one-inch NPT female threads in both inlet and outlet ports. The end of the inlet pipe should be filed smooth and square before fitting to the meter for best accuracy.
2. Position - The Flotrac meter may be mounted in either horizontal or vertical piping. When mounted horizontally, the dial face should be upward.
3. Bypass - The meter installation should include a bypass line to allow meter inspection or repair without interrupting the flow of liquid. Refer to illustration below:

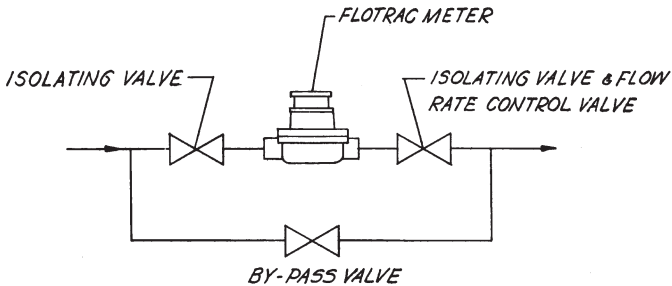

4. Control Valve - flow rate control valve must always be installed downstream from Flotrac meter. Experience has indicated that pressure drop across control valves will cause undue turbulence and, in some cases, vaporization of the liquid. This may result in cavitation and erroneous meter readings.

Operation

Basic Theory

Liquid flowing through the meter turns the rotor. The rotor is magnetically connected to a shaft, which in turn is connected through gears to a readout register. The turns of the rotor are indicated on the register.

Meter Operation (See M306 Cross-section View on previous page)

The process liquid enters the metering chamber through the inlet connection. As the liquid follows the 360 degree loop, it is separated into two equal streams. These two streams are forced into a series of vortices in the body and cover inserts and cause the rotor to rotate in proportion to the rate of flow.

Rotation of the rotor is transmitted through the shaft and gears to the register assembly, where the liquid flow is indicated.

Both liquid streams rejoin at the meter outlet which is in direct line with the meter inlet.

Startup Procedure

A. Practical Considerations

The following practices should be observed when installing and starting a Flotrac meter. See cross-sectional illustration above and by-pass location drawing at the top of the next page.

1. Strainer

A strainer should be installed upstream from the Flotrac meter if rock fragments, weld slag or debris may be introduced into the flow line. Some sand is permissible.

2. Water Treatment

If dissolved calcium carbonates (CaCO_3) or salts are excessive, treatment is required to prevent scale buildup on the rotor journal and housing parts.

3. Air Eliminator

If the liquid stream contains substantial amounts of dissolved gas or vapors, an air eliminator should be installed upstream from the meter for the best accuracy.

B. Startup

1. Before installing the Flotrac meter, purge flow lines to remove debris.
2. After installation of the meter, close isolation valves and open bypass valve. Flow through the bypass manifold for sufficient time to eliminate air in the flow line. High velocity air or gas can cause rotor bearing damage.
3. Open isolation valve ahead of the meter slowly to eliminate hydraulic shock while charging the meter with liquid. Open the valve to full open.
4. Open isolation valve downstream to permit the meter to operate.
5. Close the bypass valve.
6. Adjust the downstream valve to provide the required flow rate through the meter.

NOTE: The downstream isolation valve may be used as a flow control valve.

SECTION 3 - MAINTENANCE/CALIBRATION

WARNING

A METER IN LINE SHOULD BE DISASSEMBLED ONLY AFTER PRESSURE IS REMOVED FROM THE LINE.

Periodic Maintenance

Regular inspection and preventive maintenance should insure extended trouble-free operation. The following procedure is suggested as a basis for a maintenance program. However, the program should be adapted to the corrosiveness or abrasiveness of the metered liquid.

1. Inspect rotor assembly every 50,000 barrels.
2. Inspect tube seal every 50,000 barrels.
3. Inspect support bearing every 50,000 barrels.
4. Inspect the register assembly semiannually.
5. Inspect body and O-rings annually. If severe abrasion or corrosion is anticipated, inspect more frequently.

Lubrication

The input shaft, outboard bearing and pinion should be lubricated at least twice a year.

A. Input Shaft

Lubricate with several drops of No. 10 motor oil or equivalent.

B. Outboard Bearing

The oil impregnated bronze bearing requires no additional lubrication.

C. Pinion

Add standard weight grease on pinion teeth and mating gear.

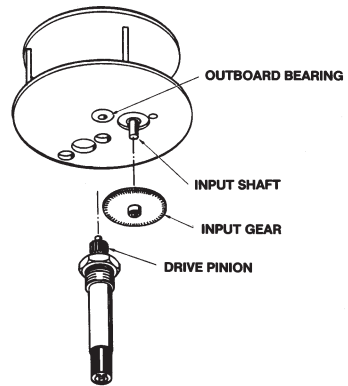

Flotrac Register — Partial Exploded View

Tools Required

The following tools are required to perform calibration and maintenance adjustments on the Model 306:

Description	Purpose
3/8" Hex Key	To remove body screws.
Screwdriver	To remove register assembly and inserts.
7/8" Box End Wrench or Socket	To remove tube seal.
9/16" Box End Wrench or Socket	To remove support bearing.
1/32" Punch	To remove spiral pin.
Truarc Pliers 52A or Equivalent	To remove grip ring.

Troubleshooting

If trouble develops, the procedures listed in Table below will usually locate the problem and suggest a solution. Normally, problems will be restricted to the rotor assembly, magnetic drive coupling or register assembly.

Trouble	Possible Sources	Probable Cause	Corrective Action
No Indication on Register	Rotor Assembly	Debris in case.	Clean debris from meter. Inspect for broken or worn parts.
	Output Shaft	Broken shaft.	Replace shaft.
	Drive or Driven Gears	Broken teeth.	Replace gears.
	Register Assembly	Broken gears or shafts.	Return to factory for repair.
Low Flow Indication	Bypass Valves	Leaky valves.	Replace or repair valves.
	Low Flow Rates		Increase flow rate to above 10 GPM.
High Flow Indication	Gas in Liquid		Install gas eliminator ahead of Flotrac meter.

Calibration

The Model 306 Flotrac Meter was calibrated at the factory using clean water. If subsequent proving shows a change in the calibration constant, the meter can be corrected by changing the calibration gears.

The required correction is determined by comparing the **True Volume** of fluid passing through the meter during a proving procedure with the **Metered Volume** shown on the register. The required correction is:

$$\text{Correction (\%)} = \left(\frac{\text{True Volume}}{\text{Metered Volume}} - 1 \right) \times 100$$

The new pinion and input gears should be selected so that the percent change in gear ratio is as nearly equal to the correction as possible. This may be accomplished with the aid of U.S. Barrel Registers Table on page 7 or Liters/Cubic Meters Registers Table on page 8).

Example:

Gear Combination..... Pinion - 18T, Input - 75T

True Volume 100 Bbl

Metered Volume 104 Bbl

The required correction is:

$$\left(\frac{100}{104} - 1 \right) \times 100 = -3.85\%$$

Using "US Barrels" Table below, move along the vertical axis (at P/I combination) to 18/75. As shown, selection of a new pinion input gear combination with a 17-tooth pinion gear and a 74-tooth input gear will result in a -4.28 correction. The new metered volume will therefore be $104 \times (1 - 0.0428) = 99.55$ gallons for a residual error of $(100 - 99.55)/100$ or -0.45%, which is within specification.

**U.S. Barrels
Pinion-Input Gear Selection
% Change to New Combination
To New Combination**

P I	12	17	17	17	17	17	17	18	18	18	18	18
	49	72	73	74	75	76	72	73	74	75	76	
12		-	-	-	-	-	+	+	-	-	-	
49	0.00	3.59	4.91	6.19	7.44	8.66	2.08	0.68	0.68	2.00	3.29	
17	+		-	-	-	-	+	+	+	+	+	
72	3.72	0.00	1.37	2.70	4.00	5.26	5.88	4.43	3.02	1.65	0.31	
17	+	+		-	-	-	+	+	+	+	+	
73	5.16	1.39	0.00	1.35	2.67	3.95	7.35	5.88	4.45	3.06	1.70	
17	+	+	+		-	-	+	+	+	+	+	
74	6.60	2.78	1.37	0.00	1.33	2.63	8.82	7.33	5.88	4.47	3.10	
17	+	+	+	+		-	+	+	+	+	+	
75	8.04	4.17	2.74	1.35	0.00	1.32	10.29	8.78	7.31	5.88	4.49	
17	+	+	+	+	+		+	+	+	+	+	
76	9.48	5.56	4.11	2.70	1.33	0.00	11.76	10.23	8.74	7.29	5.88	
18	-	-	-	-	-	-	-	-	-	-	-	
72	2.04	5.56	6.85	8.11	9.33	10.53	0.00	1.37	2.70	4.00	5.26	
18	-	-	-	-	-	-	+	-	-	-	-	
73	0.68	4.24	5.56	6.83	8.07	9.28	1.39	0.00	1.35	2.67	3.95	
18	+	-	-	-	-	-	+	+	-	-	-	
74	0.68	2.93	4.26	5.56	6.81	8.04	2.78	1.37	0.00	1.33	2.63	
18	+	-	-	-	-	-	+	+	+	-	-	
75	2.04	1.62	2.97	4.28	5.56	6.80	4.17	2.74	1.35	0.00	1.32	
18	+	-	-	-	-	-	+	+	+	+	-	
76	3.40	0.31	1.67	3.00	4.30	5.56	5.56	4.11	2.70	1.33	0.00	

The "Liters/Cubic Meters" Table on the next page is used in the same way to correct meters which have metric registers.

Part numbers of the various pinion and input gear assemblies are provided in Part Number Table at the top of page 9.

**Liters or Cubic Meters
Pinion-Input Gear Selection
% Change to New Combination
To New Combination**

P I	23	23	23	23	24	24	24	24	25	25	25	25	26	26	26	26
	65	66	67	68	65	66	67	68	65	66	67	68	65	66	67	68
23 65	0.00	1.52	2.99	4.41	4.35	2.77	1.23	0.26	8.70	7.05	5.45	3.90	13.04	11.33	9.67	8.06
23 66	+		-	-	+	+	+	+	+	+	+	+	+	+	+	+
23 67	3.08	1.52	0.00	1.47	7.56	5.92	4.35	2.81	12.04	10.34	8.70	7.10	16.52	14.76	13.04	11.38
23 68	+	+	+		+	+	+	+	+	+	+	+	+	+	+	+
24 65	4.62	3.03	1.49	0.00	9.16	7.51	5.91	4.35	13.71	11.99	10.32	8.70	18.26	16.47	17.73	13.04
24 66	-	-	-	-		-	-	-	+	+	+	-	+	+	+	+
24 67	4.17	5.62	7.03	8.39	0.00	1.52	2.99	4.41	4.17	2.59	1.06	0.43	8.33	6.69	5.10	3.55
24 68	-	-	-	-	+		-	-	+	+	+	+	+	+	+	+
26 65	2.69	4.17	5.60	6.99	1.54	0.00	1.49	2.94	5.77	4.17	2.61	1.10	10.00	8.33	6.72	5.15
26 66	-	-	-	-	+	+		-	+	+	+	+	+	+	+	+
26 67	1.22	2.71	4.17	5.58	3.08	1.52	0.00	1.47	7.37	5.74	4.17	2.63	11.67	9.97	8.33	6.74
26 68	+	-	2.74	4.17	4.62	3.03	1.49	0.00	8.97	7.32	5.72	4.17	13.33	11.62	9.95	8.33
25 65	8.00	9.39	10.75	12.06	4.00	5.45	6.87	8.24	0.00	1.52	2.99	4.41	4.00	2.42	0.90	0.59
25 66	-	-	-	-	-	-	-	-	+		-	-	+	+	+	+
25 67	6.58	8.00	9.37	10.71	2.52	4.00	5.43	6.82	1.54	0.00	1.49	2.94	5.6	4.00	2.45	0.94
25 68	-	-	-	-	-	-	-	-	+	+		-	+	+	+	+
26 65	5.17	6.61	8.00	9.35	1.05	2.55	4.00	5.41	3.08	1.52	0.00	1.47	7.2	5.58	4.00	2.47
26 66	-	-	-	-	+	-	-	-	+	+	+		+	+	+	+
26 67	3.75	5.21	6.63	8.00	0.43	1.09	2.57	4.00	4.62	3.03	1.49	0.00	8.8	7.15	5.55	4.00
26 68	-	-	-	-	-	-	-	-	-	-	-	-	-	-	-	-
26 65	11.54	12.88	14.18	15.44	7.69	9.09	10.45	11.76	3.85	5.30	6.72	8.09	0.00	1.52	2.99	4.41
26 66	-	-	-	-	-	-	-	-	-	-	-	-	+		-	-
26 67	10.18	11.54	12.86	14.14	6.27	7.69	9.07	10.40	2.37	3.85	5.28	6.67	1.54	0.00	1.49	2.94
26 68	-	-	-	-	-	-	-	-	-	-	-	-	+	+		-
26 65	8.82	10.20	11.54	12.84	4.85	6.29	7.69	9.05	0.89	2.39	3.85	5.26	3.08	1.52	0.00	1.47
26 66	-	-	-	-	-	-	-	-	+	-	-	-	+	+		+
26 67	7.46	8.86	10.22	11.54	3.43	4.90	6.31	7.69	0.59	0.93	2.41	3.85	4.62	3.03	1.49	0.00
26 68	-	-	-	-	-	-	-	-	-	-	-	-	-	-	-	-

Gear Part Numbers

Part Number	For Use With U.S. Barrels Registers
0306.0042.C	Pinion Gear, 12T
0306.0047.C	Pinion Gear, 17T
0306.0013.C	Pinion Gear, 18T
0306.0026.B	Input Gear Assembly, 49T
0306.0027.B	Input Gear Assembly, 72T
0306.0028.B	Input Gear Assembly, 73T
0306.0029.B	Input Gear Assembly, 74T
0306.0030.B	Input Gear Assembly, 75T
0306.0031.B	Input Gear Assembly, 76T

Part Number	For Use With Liters or Cubic Meters Registers
0380.1016.C	Pinion Gear, 23T
0380.1018.C	Pinion Gear, 24T
0380.1017.C	Pinion Gear, 25T
0306.1027.C	Pinion Gear, 26T
0306.1039.B	Input Gear Assembly, 65T
0380.1019.B	Input Gear Assembly, 66T
0380.1021.B	Input Gear Assembly, 67T
0380.1020.B	Input Gear Assembly, 68T

Repair

Repairs are readily made on the meter, either in-line or on the bench. Remember that all threads are right-handed, and that parts should be installed in reverse order of removal. In addition, O-rings should be inspected prior to reassembly, and replaced if cuts or swelling are evident.

To protect the register, it should be removed by unscrewing two cover screws, lifting off the case, register and gasket.

Repairs to the faceplate are limited to replacing the glass if it is broken. This requires the installation of a new retaining ring, since the ring breaks when removed.

Removal and installation procedures for major components are covered in the following paragraphs:

A. Rotor Replacement

1. **To remove rotor** - Remove six body screws with 3/8" hex key, lift off meter cover (with its O-ring in place), then slip old rotor off journal tube noting direction of rotor blades.
2. **To install rotor** - Place rotor on journal tube with flat side of blades facing fluid now, as noted during disassembly, slide cover with its O-ring and rotor into body cavity with dowel pin aligned with cover. The O-ring should fit into its groove without pinching and the body cap screws evenly tightened.

B. Journal Tube Replacement

1. **To remove tube assembly** - If the meter is in its normal position, with the register up, the tube can be removed without taking the cover off. Taking the 7/8" wrench, unscrew the tube without bending the exposed shaft. The tube can then be lifted out of the cover, leaving the rotor in the meter. The slight resistance that is felt is supplied by the O-ring.

If the meter is not in the normal position, the tube should be removed after taking the cover off, since the rotor will not remain centered after the tube is withdrawn.

B. Journal Tube Replacement (continued)

2. **To install the tube assembly** - Align the rotor with the tube, insert the tube into the cover with care not to pinch the O-ring as it slides into place, and tighten the tube with the wrench.

NOTE: The cover register cavity must be dry at all times.

C. Input Gear and Pinion Replacement

1. **To remove the input gear and pinion** - First remove the journal tube assembly as instructed in the preceding section. With a 1/32" punch, drive the pinion spiral pin from the shaft assembly and remove the pinion. With a small screwdriver, loosen the input gear set screws and remove the input gear from the input gear shaft.

NOTE: For the proper combinations of input gear and pinion, refer to Gear Selection Tables on pages 7 and 8.

2. **To install the input gear and pinion** - Reinstallation is accomplished by reversing the procedure described in the preceding paragraph.

D. Output Shaft Bearing Replacement

1. **To remove shaft assembly** - After removing the register, use a 9/16" socket or box end wrench to unscrew the bearing support assembly (including the shaft), driven magnet and output pinion. To remove the shaft from the assembly it is necessary to push out the small pin in the pinion with a 1/32" punch, supporting the shaft so it will not be bent. After sliding pinion off, remove the shaft from the bearing support. If required, the magnet can be taken off by using Truarc Pliers, No. 52A, to take the grip ring off the shaft.
2. **To install the shaft assembly** - The bearing support and its bearings are replaced as a unit, the shaft inserted with the magnet at the end opposite the wrench hexagon, the pinion is placed with its pin hole aligned with that of the shaft, and the pin installed with care again not to bend shaft. The assembly, with O-ring in place, should then be inserted into the journal tube and tightened.

E. Insert Replacement

1. **To remove inserts** - Remove the meter cover, slip off the rotor, unscrew two screws in each insert (note porting orientation), and lift out. Calcium carbonate deposits will make this difficult if the water is not treated. Each insert has a thrust washer that can be removed with light force. These washers can be reversed to present a new surface to the rotor, or replaced-if worn.
2. **To install inserts** - Place each insert with its washer in the proper housing with porting oriented properly. Fasten with the flat head screws below the insert surface. Reassemble the rotor, cover, body O-ring, and fasten down as before.

F. Register

If register is damaged, replacement of complete register is recommended.

Conversion to Model 380

The Model 306 Flotrac Meter (capacity 9-90 gpm) can be converted to a Model 380 Flow Meter (capacity 1.5-15 gpm) by replacing the parts noted in the Table below. When making this conversion, refer to M306 and M380 Parts Drawings and Parts Lists in Section 5 (starting on page 14). Replace worn parts as necessary (refer to Repair Procedure starting on page 9).

WARNING

**REMOVE ALL LINE PRESSURE FROM THE METER
BEFORE REMOVING THE METER COVER CAP SCREWS.**

Conversion to Model 380

REMOVE				INSTALL			
(See M306 Parts Drawing)				(See M380 Parts Drawing)			
Item No.	Qty.	Part No.	Description	Item No.	Qty.	Part No.	Description
25	1	Per M306 Parts List	Register Assembly	26	1	Per M380 Parts List	Register Assembly
27	1		Input Gear Assy.	27	1		Input Gear Assy.
29	1		Driver Pinion Gear	29	1		Driver Pinion Gear
31	1	0003.0011.T	Gear Lock Pin	31	1	0003.0011.T	Gear Lock Pin
9	1	0306.0006.C	Cover Insert	9	1	0380.1010.C	Cover Insert
8	1	0306.0001.B	Rotor Assembly	8	1	0380.1003.B	Rotor Assembly
6	2	0112.0034.J	Retaining Screw	7	1	0112.1040.J	Retaining Screw
5	2	0112.0034.J	Retaining Screw	10	3	0112.1001.J	Retaining Screw
—	—	—	—	4	1	0001.1014.R	O-Ring
—	—	—	—	12	1	0001.1014.R	O-Ring
—	—	—	—	42	2	0380.1031.C	Shim

SECTION 4 - INSTALL/DIMENSIONAL DRAWINGS

Model 306

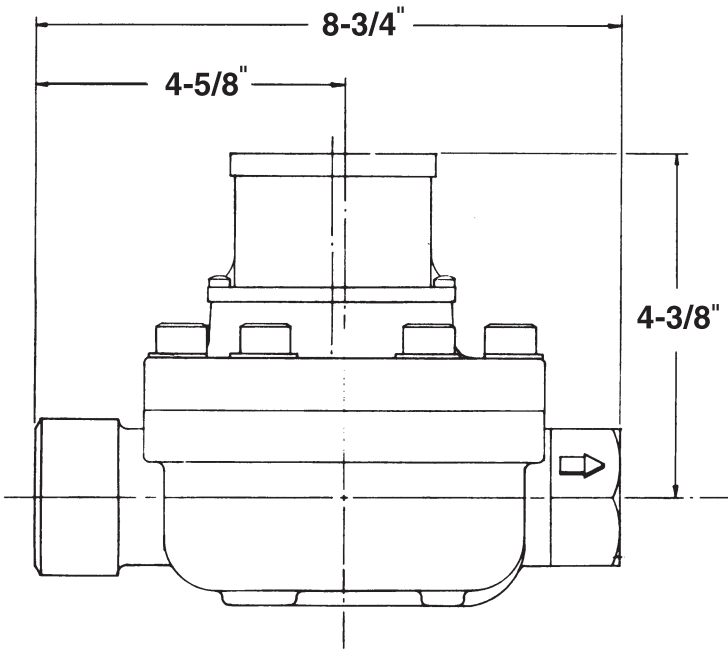
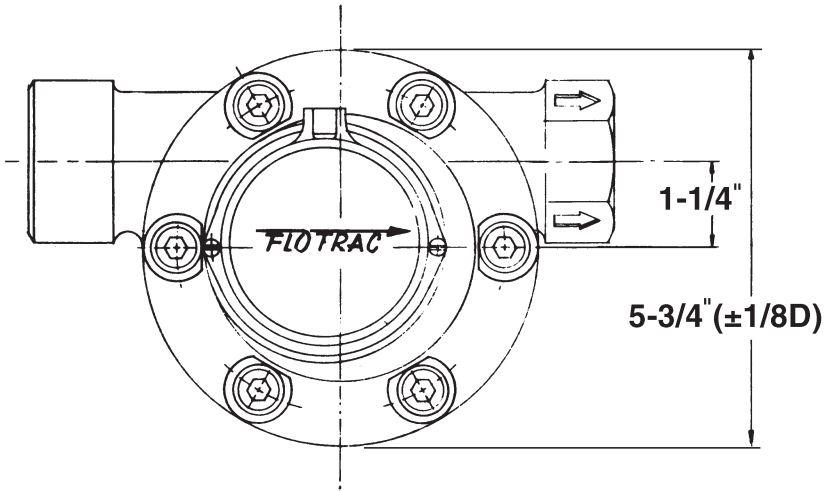

Note: Measurements are in inches.

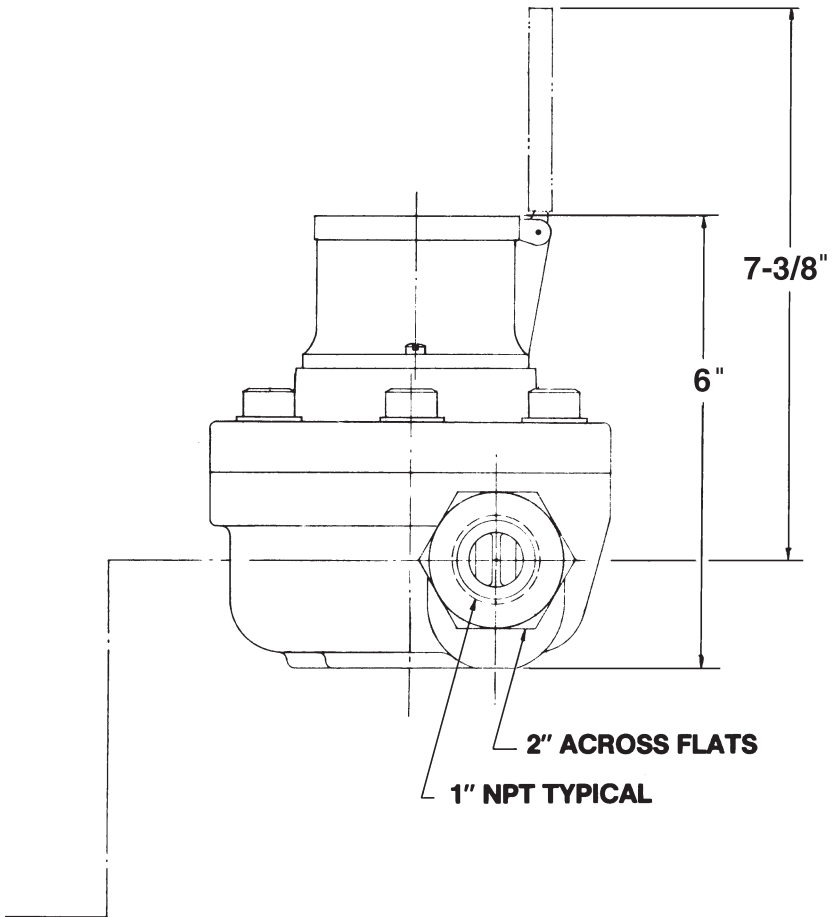

SECTION 5 - PARTS DRAWING/LIST

306 Parts Drawing

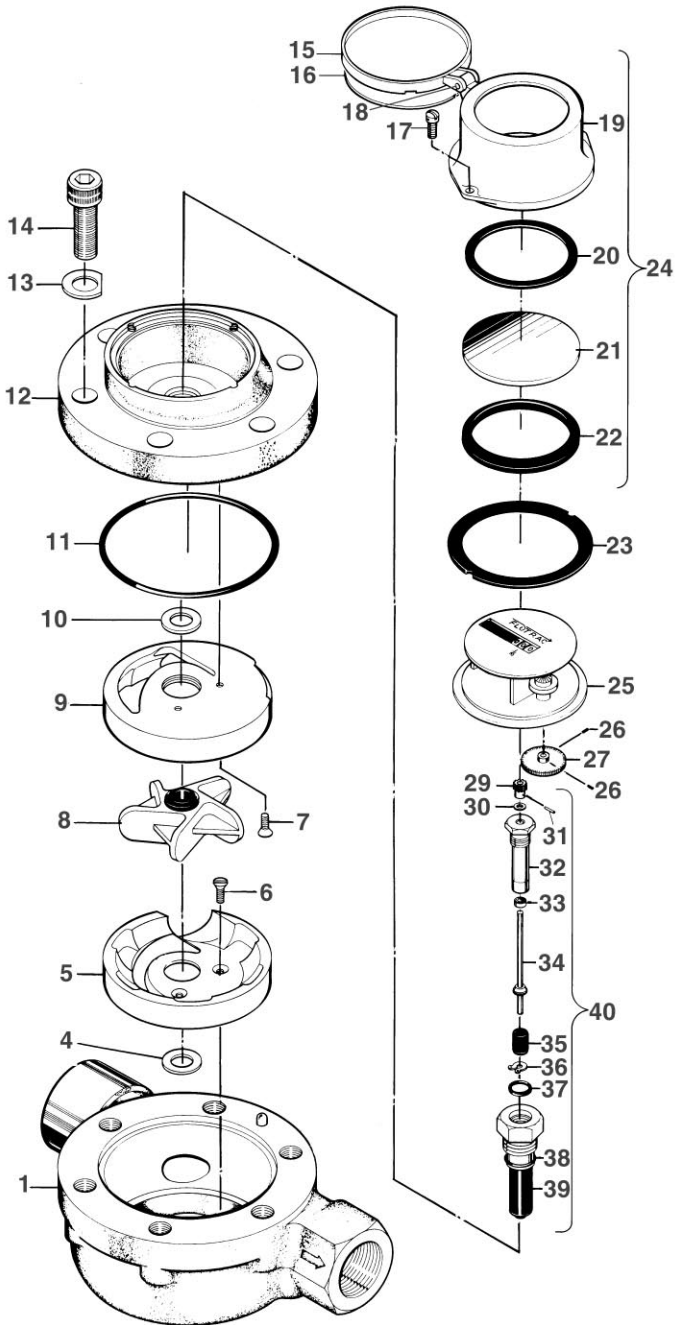

306 Parts List

Item	Description	Part No.	Per Unit
1	Meter Body & Dowel Assembly		1
	Nickel Plated	0306.0022.B	
	Epoxy Coated	0306.1005.B	
2	Not Used	—	—
3	Not Used	—	—
4	Washer, Thrust, Chrome Plated	0306.0039.C	1
*5	Insert, Housing, Ryton	0306.0005.C	1
*6	Screw (#8-32 x $\frac{3}{8}$ Sl. Fl. Hd., S.S.)	0112.0034.J	2
*7	Screw (#8-32 x $\frac{3}{8}$ Sl. Fl. Hd., S.S.)	0112.0034.J	2
*8	Rotor Assembly, Ryton	0306.0001.B	1
*9	Insert, Cover, Ryton	0306.0006.C	1
10	Washer, Thrust, Chrome Plated	0306.0039.C	1
11	O-Ring, Buna N	0001.0076.R	1
12	Cover Meter		1
	Nickel Plated	0306.0004.C	
	Epoxy Coated	0306.1008.C	
13	Washer	0306.0050.C	6
**14	Screw ($\frac{1}{2}$ -20 x 1 $\frac{1}{2}$ Soc. Hd. Cap., St. C.P.)	0220.0042.J	6
15	Lid, Register	0306.0007.C	1
16	Nameplate	0306.0001.G	1
17	Screw (#10-32 x $\frac{1}{2}$ Fill. HD. SCR. SST)	0000.1612.0	2
18	Pin, Lid — Register Box	0000.0292.0	1
19	Housing, Register	0306.0049.C	1
20	Gasket, Seal	0000.1214.0	1
21	Glass, Register	0000.0337.0	1
22	Retainer, Register Glass	0000.1216.0	1
23	Gasket, Register	0000.0253.0	1
24	Register Box & Lid Assembly	0306.0006.B	1
*25	Register Assembly		1
	U.S. Barrels	0306.1014.B	
	Cubic Meters	0306.1016.B	
	Liters	0306.1021.B	
26	Screw (2-56 x $\frac{1}{8}$ Set, S.S.)	0340.0008.J	2
*27	Gear Assembly		1
	49 Teeth	0306.0026.B	
	65 Teeth	0306.1039.B	
	66 Teeth	0380.1019.B	
	67 Teeth	0380.1021.B	
	72 Teeth	0306.0027.B	
	73 Teeth	0306.0028.B	
	74 Teeth	0306.0029.B	
	75 Teeth	0306.0030.B	
	76 Teeth	0306.0031.B	
28	Not Used	—	—
*29	Drive Pinion Gear		1
	12 Teeth	0306.0042.C	
	17 Teeth	0306.0047.C	
	18 Teeth	0306.0013.C	
	24 Teeth	0380.1018.C	
	25 Teeth	0380.1017.C	
	26 Teeth	0306.1027.C	
30	Washer, Thrust (Teflon)	0306.0056.C	1
*31	Pin	0003.0011.T	1
32	Bearing Support	0306.0009.C	1
33	Ball Bearing	0001.1044.T	1
34	Shaft & Valve Assembly	0306.1003.B	1

SECTION 6 - PARTS DRAWING/LIST (continued)

306 Parts List (continued)

Item	Description	Part No.	Per Unit
35	Magnet	0306.0011.T	1
36	Retaining Ring	0087.0010.T	1
37	O-Ring, Buna N	0001.0044.R	1
38	O-Ring, Buna N	0001.0045.R	1
39	Tube Seal	0306.0001.C	1
40	Bearing Support & Output Shaft (Assembly includes Items 30, 32, 33, 34, 35, and 36.)	0306.1040.B	1

*Used when converting Model 380 to Model 306.

**No substitutions allowed.

SECTION 6 - PARTS DRAWING/LIST (continued)

380 Parts List

Item	Description	Part No.	Per Unit
1	Assembly, Meter Body and Dowel Nickel Plated Epoxy Coated	0306.0022.B 0306.1005.B	1
2	Not Used	—	—
3	Not Used	—	—
†** 4	O-Ring, Buna-N	0001.1014.R	1
† 5	Washer, Thrust	0306.0039.C	1
** 6	Insert, Body	0380.1008.C	1
** 7	Screw, Body Insert Retaining, 8-32 x 3/4"	0112.1040.J	1
** 8	Rotor Assembly (4-Pole)	0380.1003.B	1
** 9	Cover Insert	0380.1010.C	1
**10	Screw, Cover Insert Retaining, 6-32 x 3/4"	0112.1001.J	3
11	Not Used	—	—
12	Not Used	—	—
13	O-Ring, Meter Cover (Buna-N)	0001.0076.B	1
14	Meter Cover Nickel Plated Cast Steel Epoxy Coated Cast Steel	0306.0004.C 0306.1008.C	1
15	Washer	0306.0050.C	6
16	Cap Screw, Meter Cover	0220.0042.J	6
17	Nameplate	0380.1026.G	1
18	Register Lid	0306.0007.C	1
19	Register Lid Pin	0000.0292.0	1
20	Register Housing	0306.0049.C	1
21	Screw, Register Mounting	0000.1612.0	2
22	Retainer, Register Glass	0000.1216.0	1
23	Register Glass	0000.0337.0	1
24	Gasket, Register Glass	0000.1214.0	1
25	Gasket, Register Housing	0000.0253.0	1
**26	Assembly, Register U.S. Barrels Cubic Meters Liters	0306.1015.B 0306.1020.B 0306.1022.B	1
**27	Input Gear Assembly 58 Teeth 59 Teeth 60 Teeth 66 Teeth 67 Teeth 68 Teeth	0306.1036.B 0306.1037.B 0306.1038.B 0380.1019.B 0380.1021.B 0380.1020.B	1
28	Set Screw, Input Gear, 2-56 x 1/8", St. St.	0348.0008.J	2
**29	Driver Pinion Gear 23 Teeth 24 Teeth 25 Teeth 32 Teeth 33 Teeth 34 Teeth 35 Teeth	0380.1016.C 0380.1018.C 0380.1017.C 0306.1029.C 0306.1030.C 0306.1031.C 0306.1032.C	1
30	Washer, Thrust (Teflon)	0306.0056.C	1
**31	Pin, Drive Pinion Gear Lock	0003.0011.T	1
32	Assembly, Bearing Support	0306.0009.C	1
33	Bearing, Output Shaft (Ball Bearing)	0001.1044.T	1
34	Assembly, Output Shaft and Valve	0306.1003.B	1
35	Magnet, Driven (4-Pole)	0036.0011.T	1
36	Snap Ring, Magnet Retaining	0087.0010.T	1

M380 Parts List (continued)

Item	Description	Part No.	Per Unit
37	O-Ring (Buna-N)	0001.0044.R	1
38	O-Ring (Buna-N)	0001.0045.R	1
39	Tube Seal	0306.0001.C	1
40	Assembly, Bearing Support & Output Shaft (Includes Items 30, 32, 33, 34, 35 & 36)	0306.1040.B	1
41	Assembly, Register Box & Lid (Includes Items 17, 18, 19, 20, 21, 22, 23, & 24)	0306.0006.B	1
††**42	Shim	0380.1031.C	2

†Recommended Spare Parts.

††Not shown. Install one above cover insert, one below body insert.

**Replace when converting to Model 306.

Product Warranty

A. Warranty

Cameron International Corporation ("Cameron") warrants that at the time of shipment, the products manufactured by Cameron and sold hereunder will be free from defects in material and workmanship, and will conform to the specifications furnished by or approved by Cameron.

B. Warranty Adjustment

- (1) If any defect within this warranty appears, Buyer shall notify Cameron immediately.
- (2) Cameron agrees to repair or furnish a replacement for, but not install, any product which within one (1) year from the date of shipment by Cameron shall, upon test and examination by Cameron, prove defective within the above warranty.
- (3) No product will be accepted for return or replacement without the written authorization of Cameron. Upon such authorization, and in accordance with instructions by Cameron, the product will be returned shipping charges prepaid by Buyer. Replacements made under this warranty will be shipped prepaid.

C. Exclusions from Warranty

- (1) THE FOREGOING WARRANTY IS IN LIEU OF AND EXCLUDES ALL OTHER EXPRESSED OR IMPLIED WARRANTIES OF MERCHANTABILITY, OR FITNESS FOR A PARTICULAR PURPOSE, OR OTHERWISE.
- (2) Components manufactured by any supplier other than Cameron shall bear only the warranty made by the manufacturer of that product, and Cameron assumes no responsibility for the performance or reliability of the unit as a whole.
- (3) "In no event shall Cameron be liable for indirect, incidental, or consequential damages nor shall the liability of Cameron arising in connection with any products sold hereunder (whether such liability arises from a claim based on contract, warranty, tort, or otherwise) exceed the actual amount paid by Buyer to Cameron for the products delivered hereunder."
- (4) The warranty does not extend to any product manufactured by Cameron which has been subjected to misuse, neglect, accident, improper installation or to use in violation of instructions furnished by Cameron.
- (5) The warranty does not extend to or apply to any unit which has been repaired or altered at any place other than at Cameron's factory or service locations by persons not expressly approved by Cameron.

Product Brand

Barton® is a registered trademark of Cameron International Corporation ("Cameron").

Sensia LLC

200 Westlake Park Blvd

Houston, TX 77079

+1-866-773-6742

sensiaglobal.com